

INTERNATIONAL CONFERENCE ON RESEARCH IN EDUCATION & SCIENCE

 **ICRES2019**

April 28-May 1, 2019

Cesme/TURKEY

PROCEEDING BOOK

EDITORS

Prof. Dr. Mack Shelley
Prof. Dr. Mehmet Ozaslan
Dr. Wenxia Wu

Volume I



<http://www.icres.net>

INTERNATIONAL CONFERENCE ON RESEARCH IN EDUCATION & SCIENCE

Editors: Mack Shelley, Mehmet Özaslan, Wenxia Wu

This book was typeset in 10/12 pt. Times New Roman, Italic, Bold and Bold Italic.

Copyright © by ISRES Publishing.

All rights reserved. No part of this book may be reproduced in any form, by photostat, microfilm, retrieval system, or any other means, without prior written permission of the publisher.

International Conference on Research in Education and Science (ICRES) Published by ISRES Publishing, International Society for Research in Education and Science (ISRES).

Includes bibliographical references and index.

ISBN: 978-605-81654-7-2

Date of Issue: October 01, 2019

Address: Prof. Dr. Mack Shelley, Iowa State University, 509 Ross Hall,
Ames, IA 50011-1204, U.S.A.

E-mail: isresoffice@gmail.com

www.isres.org



<http://www.icres.net>

INTERNATIONAL CONFERENCE ON RESEARCH IN EDUCATION & SCIENCE

Keynote Speakers



Dr. Ton de Jong
University of Twente

"Acquiring 21st Century Skills by STEM Students; a Technological Approach Based on Inquiry Learning with Virtual Laboratories"



Dr. Evgenia (Jenny) Sendova
Institute of Mathematics and Informatics at the Bulgarian Academy of Sciences

"Good Practises Using Digital Technologies in STEM Education with a Focus on Math Education"



Dr. Günter Törner
University of Duisburg-Essen

"The Role of STEM in the Schooling of Students"



Dr. Muhammad M. Zayyad
Al-Qasemi Academic College of Education

"STEAM and Students with Learning Disabilities"



INTERNATIONAL CONFERENCE ON RESEARCH IN EDUCATION & SCIENCE

Committees

CONFERENCE PRESIDENTS

Prof. Dr. Mack SHELLEY - Iowa State University, United States
Prof. Dr. Mehmet OZASLAN - Gaziantep University, Turkey
Dr. Wenxia WU - Eastern Virginia Medical School, United States

SCIENTIFIC BOARD

Allan TARP - MATHeCADEMY, Denmark
Altay FIRAT - European University of Lefke, Cyprus
Andrea DEBELJUH - University Juraj Dobrila of Pula, Croatia
Brahim FERDI - Bechar University, Algeria
Branislav POPOVIĆ - University of Kragujevac, Serbia
Chalavadi SULOCHANA - Gulbarga University, India
Dariga NURKESHEVA - Nazarbayev University, Kazakhstan
Elizabeth ADAMSON - Edinburgh Napier University, United Kingdom
Farhad BALASH - Kharazmi University, Iran
Farouq ALMEQDADI - Emirates College for Advanced Education (ECAE), U.A.E.
Gordana SAVIC - University of Belgrade, Serbia
Haydar YUKSEK - Kafkas University, Turkey
Henry David KATNIYON - Federal College of Education, Pankshin, Plateau state, Nigeria
Hsin-Chih WU - National Taiwan Normal University, Taiwan
Jessie BUSTILLOS - London Metropolitan University, United Kingdom
Mesut AYDIN - Inonu University, Turkey
Milica PAVKOV HRVOJEVIĆ - University of Novi Sad, Serbia
Mohammad Sarwar – Scialert, Dubai, United Arab Emirates
Morteza BARIN - Farhangiyani University of Iran, Iran
Muteb ALQAHTANI - Rutgers University, United States
Nurten SARGIN - Necmettin Erbakan University, Turkey
Ognyan B. MANOLOV - European Polytechnic University, Bulgaria
Sanaa AL-DELAIMY - Mosul University, Iraq
Shynar BAIMAGANBETOVA - Nazarbayev University, Kazakhstan
Summer MOUALLEM - University of Central Lancashire, United Kingdom
Tamer USTUNER - Kahramanmaraş Sutcu Imam University, Turkey
Tri Marhaeni PUDJI ASTUTI - Semarang State University, Indonesia



INTERNATIONAL CONFERENCE ON RESEARCH IN EDUCATION & SCIENCE

Committees

ORGANIZING COMMITTEE

- Aliya MUSTAFINA - Nazarbayev University, Kazakhstan
Ann D. THOMPSON - Iowa State University, United States
Cemil AYDOĞDU - Hacettepe University, Turkey
Ersin KARADEMİR - Eskisehir Osmangazi University, Turkey
Halil SNOPE - South East European University, Macedonia
Jacqueline T. MCDONNOUGH - Virginia Commonwealth University, United States
Mariusz JAWORSKI - Medical University of Warsaw, Poland
Mary M. CAPRARO - Texas A&M University, United States
Mehmet OZASLAN - Gaziantep University, Turkey
Muhammad ZAYYAD - Al-Qasemi Academic College of Education, Israel
Murat BEYTUR - Kafkas University, Turkey
Mustafa PEHLIVAN - Necmettin Erbakan University, Turkey
Natela DOGHONADZE - International Black Sea University, Georgia
Natalija ACESKA - Ministry of Education and Science, Macedonia
Ossi AUTIO - University of Helsinki, Finland
Omer Tayfur OZTURK - Necmettin Erbakan University, Turkey
S. Ahmet KIRAY - Necmettin Erbakan University, Turkey
Silvia MORARU - National High School Bucharest, Romania
Tolga ERDOGAN - Karadeniz Technical University, Turkey

Participating Countries

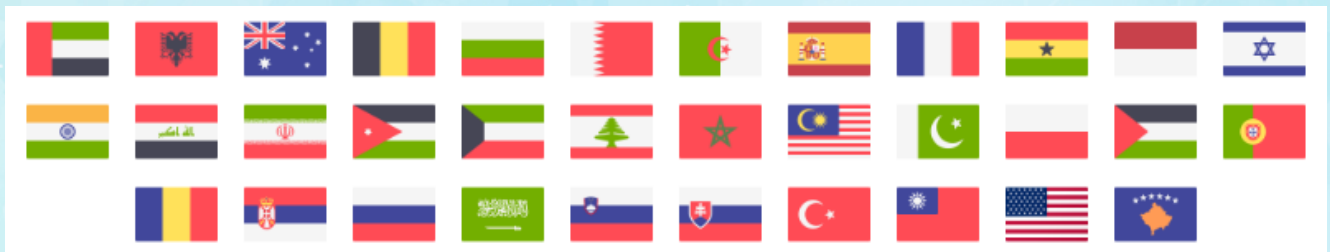

INDEX

MyMathLab & WebAssign: Students' Perceptions of their use in Mathematics	
<i>Derar SERHAN Farouq ALMEQDADI</i> ,.....	1
The Perception on Need and Impact of Private Supplementary Tutoring at Higher secondary level in Delhi Region of India: An Exploratory Study	
<i>Harshita SHARMA</i>	5
How Close Are Teachers to Think in a Scientific Manner?	
<i>Naz Fulya OZKARABACAK, Ayse OGUZ UNVER</i>	17
M.I.S.O. – Motion In The Science Ocean - Erasmus+ project - Use of Powtoon, Easyclass and Mentimeter in a High School Debate using the the WSDC model	
<i>Luisa SANTOS, Neusa FERNANDES, Guilherme JORGE, Lucio MAGALHAES, Mafalda BROCHADO, Mariana REBELO, Miguel LEDO, Lara FERREIRA, Zenaida CODIA, Beatriz VILAS-BOAS</i>	24
An Investigation of Pre-service Middle School Mathematics Teachers' Discussion Skills in the Context of Microteaching Lesson Study	
<i>Nadide YILMAZ, I. Elif YETKIN-OZDEMIR</i>	37
Learning Through Exploration and Research	
<i>Andreja MARZI</i>	44
Marketing of Library and Information Services in University Libraries: A Case Study of University of Malaya Central Library, Kuala Lumpur, Malaysia	
<i>Siti Juryiah MOHD KHALID</i>	50
Mind Mapping as one of the Ways of Creative Thinking	
<i>Dagmar RUSKOVA, Lubica VASKOVA</i>	60
Observing the Impact of Science Education on Undesirable Behaviors of Students in the Agent-based Simulation Environment	
<i>Sebnem BORA Gizem CENGİN UNUVAR, Sevcan EMEK</i>	64
Mixing Languages in the Spoken Discourse of the Algerian Radio Broadcasters: a Strategy for an Effective Communication	
<i>Horiya AMAR BEKADA, Soraya HAMANE</i>	72
Art in Industrialization Process: Change and Transformations in Art after 20th Century	
<i>Mehmet SUSUZ, Mahmut Sami OZTURK</i>	81
Pulling Back the Curtain ' The Relationship between Teacher Quality and Students' Educational Outcomes and Its Effect on the Communities Issues	
<i>Adel Dagher FAHED BUDAGHER</i>	89
Arabic and English Conditional Clauses: A Comparative Study	
<i>Samar Sami HAMMADI</i>	109
Designing Investigation Methods to Research Indiscernible Impediments of an Invisible Equity Group in Australian Higher Education	
<i>Ganesh KORAMANNIL</i>	115
The influence of an In- Service Training Program on English Language Teachers' Professional Development in Palestinian Upper Primary Public Schools	
<i>Suzan QINDAH</i>	124
The Evaluation of the Relationship between the Academic Achievement of Social Studies Teacher Candidates and Their Attitudes towards Environment	
<i>Ozkan AKMAN, Mustafa Murat CAY</i>	136

The Contribute of the Word Roots in Reading among Normal and Dyslexic Readers	
<i>Haneen WATTAD</i>	140
An Artificial Intelligent of Princess Mandalika Legend: A New Strategy to Sustain the Resort of Mandalika-Lombok	
<i>Yuke ARDHIATI</i>	148
Comparative Study Based on Quality Indicators of Academic Activities	
<i>Silvia VERESIU, Elena MEREUTA, Madalina Alice RUS, Daniel GANEA, Valentin AMORTILA</i>	155
Towards the Design of a Didactic Engineering Relying on Economy as a Semiotic Model of Mathematics	
<i>Pierre JOB, Jean-Yves GANTOIS</i>	160
8th Grade Kemalism and Revolution History Textbook Investigation of Social Studies Teacher Candidates' Opinions	
<i>Ozkan AKMAN, Mustafa Murat CAY</i>	165
An Investigation of How to Refer Doing Statistics in 8th Grade Mathematics Textbooks	
<i>Nadide YILMAZ</i>	169
Dynamics of Human Resources in a Composite University Future Trends	
<i>Madalina RUS, Elena MEREUTA, Silvia VERESIU, Daniel GANEA, Valentin AMORTILA</i>	179
FLOW Theory in the Preparation of Vocational Subjects Teachers	
<i>Lubica VASKOVA, Dagmar RUSKOVA</i>	184
Organizational Change Management and Family Firms Socio Emotional Wealth: What Form of Impact?	
<i>Hind HOURMATALLAH, Mohammed KHALIS</i>	189
The Effects of the Flipped Classroom and Peer Instructional Models on Learning Calculus	
<i>Muhammed SYAM, Derar SERHAN, Farouq ALMEQDADI</i>	200
A Study on University Students' Online Information Search Strategies and Lifelong Learning Situations	
<i>Baris EMLEK, Ahmet Oguz AKTURK</i>	206
Investigation of Social Media Addiction of Middle School Students Skills	
<i>Ahmet Oguz AKTURK, Huseyin Seyhan DUYGU, Baris EMLEK</i>	213
Virtualization in Social Studies Education	
<i>Erol KOCOGLU</i>	222
The Role of Social Studies Course in Creating a Digital Self	
<i>Erol KOCOGLU</i>	226

MyMathLab & WebAssign: Students' Perceptions of their use in Mathematics

Derar SERHAN
Arizona State University

Farouq ALMEQDADI
Emirates College for Advanced Education

Abstract: Enhancing students' conceptual understanding and encouraging them to be involved in the classroom discussions are important for instructors of mathematics. The use of technology is an essential part in teaching and learning mathematics as emphasized by The National Council of Teachers of Mathematics *Principles and Standards for School Mathematics*. Web-based homework management systems provide alternatives to the traditional pen-and-paper based approaches. These systems provide a flexible instructional tool that offer students immediate feedback, track their performance, facilitate student-centered environment, allow instructors to give students more frequent assignments, provides the instructors with the ability to create multimedia enhanced questions that can include video, animation, or audio and facilitate students' communications with their instructor. The goal of using these programs is to enhance students' learning and understanding of the different mathematical concepts. The purpose of this paper is to present students' perceptions of the advantages and disadvantages of using web-based homework management systems, in particular MyMathLab and WebAssign.

Keywords: MyMathLab, WebAssign, Mathematics education, Web-based systems

Introduction

The use of web-based homework systems is becoming very popular and is gradually replacing the traditional paper based homework. Many studies have been conducted using web-based homework in chemistry, mathematics, physics and statistics courses (Bliwise, 2005; Bonham, Beichner, & Deardorff, 2001; Cole & Todd, 2003; Dufresne, Mestre, Hart, & Rath, 2002; Freasier, Collins, & Newitt, 2003; Hauk, & Segalla, 2005; Lenz, 2010; Lin, 2009; Pascarella, 2004; Penn, Nedeff, & Gozdzik, 2000; Pennington, 2013; Toback, Mershin, & Nazimova, 2005; York, Hodge & Richardson, 2008; Zerr, 2007).

Some studies focused on students' perceptions of their learning using web-based homework systems (Demirci, 2007; Hauk & Segalla, 2005; Picciano, 2002), while other studies compared between the use of web based homework systems and the use of paper-and-pencil homework (Dufresne, Mestre, Hart, & Rath, 2002; Thoennesen & Harrison, 1996).

Tang and Titus (2002) conducted a study that surveyed students of physics and calculus who used WebAssign on a weekly basis. They found that using WebAssign increased student-instructor as well as student-student interactions. The study also revealed that students put more time and effort on their homework outside the classroom. In addition, they found that the instructors in the study created learning activities based on student feedback.

Pennington (2013) conducted a study that investigated the use of ALEKS as a web-based homework system on student achievement in a college algebra course. Students in this course were required to achieve a 75% correct completion level for the online homework in order to be able to access online quizzes. Pennington collected the data using a pretest, posttest, pre-survey and post-survey methods. The pre-test was used to measure students'

- This is an Open Access article distributed under the terms of the Creative Commons Attribution-Noncommercial 4.0 Unported License, permitting all non-commercial use, distribution, and reproduction in any medium, provided the original work is properly cited.

- Selection and peer-review under responsibility of the Organizing Committee of the Conference

prior knowledge of the material before taking the course as well as to gather demographic information. The post-survey was used to gain information on students' work ethics, and their feelings towards the use of ALEKS. The researcher found that using ALEKS did not affect students' performance on their final exam but found that it had a positive effect on students' online quiz performance.

Lin (2009) conducted a study to investigate the comparative efficiency of Web-based instruction and traditional teaching methods on preservice teachers' fraction knowledge. Forty- two preservice teachers who were enrolled in two classes (21 students each) participated in this study. The experimental class used Web-based Instruction, while the other class was given traditional instruction. The researcher collected the data using pre- and posttest. The test consisted of 32 items that aimed at assessing students' knowledge of fractions. The other class was assigned as a control group (n = 21) and was given traditional instruction. The analysis of results showed that there was a statistically significant difference between the experimental and the control groups' posttest mean scores in favor of the experimental group.

York, Hodge & Richardson, J. (2008) conducted a study that examined students' perceptions of the use of web-based homework and its effect on their learning and motivation. Participants in the study were 376 university students enrolled in a college algebra class. Participants completed the majority of their homework online. The researchers evaluated students' perceptions of the web-based homework through a survey containing both Likert-scale items and open-ended questions. The researchers found that few students appreciated the immediate feedback, but most of them felt more accountable for completing the assigned work.

In the current study, we focus on two web-based systems; WebAssign and MyMathLab. WebAssign was developed by Dr. John Risley in 1997 to enhance student learning and to support instructors in their classrooms. WebAssign is a flexible web-based instructional system. It provides learners with immediate feedback on their performance thus allowing them to do more practice in the areas they need most help with. Learners may also work on their assignments multiple times until they get the correct answers. Student performance can be assessed on a regular basis.

MyMathLab is an online textbook resource that is used to generate online homework assignments. The system offers instant feedback, step-by-step examples, videos, and tutorials. MyMathLab creates a personalized adaptive study plan based on the collected data targeting each student's individual strengths and weaknesses. The goal of the adaptive plan is to improve student conceptual understanding of different mathematical concepts.

The focus of this paper is students' perceptions of the advantages and disadvantages of their use of MyMathLab and WebAssign in learning mathematics.

Research Question

The aim of this study was to answer the following question: What are students' perceptions of the advantages and disadvantages of using MyMathLab and WebAssign in learning mathematics.

Method

The participants in this study were university students enrolled in two different mathematics classes. One class used MyMathLab and the other one used WebAssign as web-based homework tools. To provide an answer to the research question, data were collected using a survey asking students to provide the advantages and disadvantages of the web-based homework system that they used based on their own experiences during the semester.

Results and Discussions

The purpose of this study was to investigate students' perceptions of the advantages and disadvantages of using MyMathLab and WebAssign in learning mathematics. Participants' responses were summarized and tabulated as follows: (Table 1) provides students' perceptions of advantages and disadvantages of using MyMathLab, and (Table 2) provides students' perceptions of the advantages and disadvantages of using WebAssign.

Table 1. Advantages and disadvantages of using MyMathLab

Advantages	Disadvantages
<p>Sample Replies:</p> <ul style="list-style-type: none"> multiple attempts, practice over and over again. being available to constantly go back and work on it. immediate feedback. the online resources are great, multiple resources such as videos. Convenience. less pressure than turning in paper assignments. online tutoring, help is immediate. you can do it anytime, anywhere, easy access. 	<p>Sample Replies:</p> <ul style="list-style-type: none"> technical difficulties, issues with the internet. abuse of resources; don't retain knowledge. no partial credit. system glitch, you enter the correct answer but the system doesn't accept it. long homework. less friendly than using a paper submission.

Table 2. Advantages and disadvantages of using WebAssign

Advantages	Disadvantages
<p>Sample Replies:</p> <ul style="list-style-type: none"> You get several tries, multiple attempts. lots of practice and variety of problems. ability to work forward or backwards thru a problem to find mistakes. it helps me see that I'm doing something wrong to correct it. easy to get help/online help, it easy to seek help from other websites. immediate feedback, quick feedback and self learning. online tutoring to help students when they don't understand something. more resources that are easy to access. being able to do it anymore on a mobile device 	<p>Sample Replies:</p> <ul style="list-style-type: none"> technical difficulties. slow, not easy to find examples. very difficult to show work so teacher knows in what areas you are struggling. if you do not understand something it is really hard to bring your laptop around places to seek help rather than a piece of paper no paper/pencil work sometimes it is hard to type answer no immediate face-to-face feedback you forget about it

As indicated in the tables above, students pointed out the following advantages to their use of web-based homework systems: the ability to redo the questions multiple times, the ability to get instant feedback, the availability of multiple resources and the flexibility of using the system. They indicated the following as disadvantages to their use of these systems: technical difficulties, forgetting due dates, and missing the use of paper and pencil. More studies are needed to explore how to improve students' experiences with these systems and to further investigate the effects of online homework systems on student achievement and understanding.

References

- Bliwise, N.G. (2005). Web-Based Tutorials for Teaching Introductory Statistics. *Journal of Educational Computing Research*, 33(3), 309-325. Retrieved from <https://www.learntechlib.org/p/69286/>.
- Bonham, S., Beichner, R., & Deardorff, D. (2001). Online homework: Does it make a difference? *The Physics Teacher*, 39(5), 293–296. <https://doi.org/10.1119/1.1375468>
- Cole, R. S., & Todd, J. B. (2003). Effects of web-based multimedia homework with immediate rich feedback on student learning in general chemistry. *Journal of Chemical Education*, 80, 1338-1343.
- Demirci, N. (2007). University students' perceptions of web-based vs. paper-based homework in a general physics course. *Eurasia Journal of Mathematics, Science & Technology Education*, 3(1), 29-34. Retrieved from <https://pdfs.semanticscholar.org/5df3/526c48645d7e8a0b5a5843f3ebd29faa41d9.pdf>

- Dufrense, R., Mestre, J., Hart, D., & Rath, K. (2002). The effect of webbased homework on test performance in large enrollment introductory physics courses. *Journal of Computers in Mathematics and Science Teaching*, 21(3), 229-251.
- Freasier, B., Collins, G., & Newitt, P. (2003). A web-based interactive homework quiz and tutorial package to motivate undergraduate chemistry students and improve learning. *Journal of Chemical Education*, 80, 1344-1347.
- Hauk, S., & Segalla, A. (2005). Student perceptions of the web-based homework program WebWork in moderate enrollment college algebra classes. *Journal of Computers in Mathematics and Science Teaching*, 24(3), 229-253.
- Lenz, L. (2010). The effect of a web-based homework system on student outcomes in a first-year Mathematics course. *The Journal of Computers Mathematics and Science Teaching* 29: 233-246.
- Lin, C.Y. (2009). A comparison study of web-based and traditional instruction on pre-service teachers' knowledge of fractions. *Contemporary Issues in Technology and Teacher Education*, 9(3), 257-279. Waynesville, NC USA: Society for Information Technology & Teacher Education. Retrieved from <https://www.learntechlib.org/primary/p/28318/>.
- Pascarella, A. M. (2004). The influence of web-based homework on quantitative problem-solving in a university physics class. In Proceedings NARST (National Association for Research in Science Teaching) Annual Meeting, Vancouver, Canada. April 1-3.
- Penn, J. H., Nedeff, V. M., & Gozdzik, G. (2000). Organic chemistry and the Internet: A web-based approach to homework and testing using the WE_LEARN System. *Journal of Chemical Education*, 77, 227-231.
- Pennington, K. (2013). *Improving College Algebra Grades Using Online Homework Completion as a Prerequisite for Quizzes*. Retrieved from https://etd.ohiolink.edu/pg_10?0::NO:10:P10_ACCESSION_NUM:akron1367337306
- Picciano, A. G. (2002). Beyond student perceptions: Issues of interaction, presence, and performance in an online course. *Journal of Asynchronous Learning*, 6(1). Retrieved January from <http://www.anitacrawley.net/Resources/Articles/Picciano2002.pdf>
- Thoennessen, M., & Harrison, M.J. (1996). Computer-assisted assignments in a large physics class. *Computers in Education*, 27(2), 141-147.
- Titus, A., & Tang, G. (2002, June), *Increasing Students' Time On Task In Calculus And General Physics Courses Through Webassign* Paper presented at 2002 Annual Conference, Montreal, Canada. <https://peer.asee.org/10436>
- Toback, D., Mershin, A., & Nazimova, I. (2005). Integrating web-based teaching tools into large university physics courses. *The Physics Teacher*, 43, 594-597.
- York, C., Hodge, A. & Richardson, J. (2008). Web-based Homework in University Algebra Courses: Student Perceptions of Learning and Motivation to Learn. In K. McFerrin, R. Weber, R. Carlsen & D. Willis (Eds.), *Proceedings of SITE 2008--Society for Information Technology & Teacher Education International Conference* (pp. 4618-4624). Las Vegas, Nevada, USA: Association for the Advancement of Computing in Education (AACE). Retrieved from <https://www.learntechlib.org/primary/p/27989/>.
- Zerr, R. (2007). A quantitative and qualitative analysis of the effectiveness of online homework in first-semester calculus. *Journal of Computers in Mathematics and Science Teaching*, 26(1), 55-73.
- Web Assign (www.webassign.com).
- MyMathLab (<http://www.pearsonmylabandmastering.com/northamerica/my-mathlab/>).

Author Information

Derar Serhan

Arizona State University
Tempe, AZ, USA
Contact E-mail: derar@asu.edu

Farouq Almeqdadi

Emirates College for Advanced Education
Abu Dhabi, UAE

The Perception on Need and Impact of Private Supplementary Tutoring at Higher secondary level in Delhi Region of India: An Exploratory Study

Harshita SHARMA

National Institute of Educational Planning and Administration

Abstract: In India where the state is mandated to provide free, compulsory and quality education to all children up to the age of fourteen years, parents still chose to send their children for the private tutoring with the hope of high academic achievement. There has been repeated reference to the adverse effects of this shadow system of education, but students still continue to access these services. Moreover, there is a sudden increase in demand of this shadow with the massification of school education. Specially at the secondary stages, which are considered most crucial for a student, defining his eligibility in global job market at this early stage itself. The study examines the perceptions of parents and students studying in higher secondary classes, residing in New Delhi towards the need of private supplementary tutoring. Additionally, the study also aims to uncover the impact of the supplementary tutoring (if any) on the academic performance of these students. Attempt has been made to study the nature and demand of private supplementary tutoring through semi-structured interview schedule presented to students and parents; of government and private schools alike. The data gathered reveals answers to three key research questions: the individual and household related factors affecting the demand for private supplementary tutoring; the reasons for rise in demand of supplementary tutoring at higher secondary levels; and the students' perception on the impact this typical tutoring model has on their academic achievement. The four A's- Accessibility, Availability, Affordability and Acceptability are also important factors associated to the study of individual and household need and choice of private supplementary education scenario.

Keywords: Private supplementary tutoring, Shadow education, Higher secondary school education, Quality education

Introduction

'Shadow Researchers from different countries have used terms like- 'tuitions', 'coaching', 'shadow education', 'tutoring', 'private supplementary tutoring', etc. to describe this system of additional private paid scaffolding systems that run parallel to formal schooling systems. The East Asian societies, deeply embedded in Confucian cultures are most popular for their competitive education regimes that deeply rely on private tutoring systems. South Korea, Japan, Taiwan and China have been described in works of Bray, 1999; Stevenson & Baker, 1992; and Kim & Lee, 2010; as being largest consumers of tutoring. Eastern Europe and former Soviet countries are not too far behind after the political transitions in 1980s and 1990s (Silova, 2010). Western Europe, Australia, United States, United Kingdom, Canada have also shown increase in private tutoring systems in the 21st century (Ireson, 2004; Davies and Aurini, 2006; Sunderman, 2007; Bray, 2009; Diskin, 2010). South Asian countries like India, Pakistan, Bangladesh; Southern Europe (Bray, 2011); African Countries like Mauritius, Malawi and Kenya (Buchmann, 2002; Foondun, 2002; Paviot et al., 2008) all show high rates of tutoring.

Rationale of the Study

India follows a principle for providing mass education. The aim is to make all its citizens receive quality education and provide an equitable 'access to success'. Owing to the international pressures the issues of access have been nearly addressed in the country but the equitable environment necessary for success of all children irrespective of their personal and community disadvantages still remains an issue. India is a heterogeneous

- This is an Open Access article distributed under the terms of the Creative Commons Attribution-Noncommercial 4.0 Unported License, permitting all non-commercial use, distribution, and reproduction in any medium, provided the original work is properly cited.

- Selection and peer-review under responsibility of the Organizing Committee of the Conference

country where the supply of a uniform and standardized system of education does not usually cater to demands of different linguistic, economic, religious and ethnicity groups.

Education has various forms in India and is provided by different organizations. Some of which are state run or aided and others privately funded. The private education again has many forms, provided in formal setups such as established schools and colleges; others through informally run private tutoring/coaching classes/centres. Private tutoring has been deep-seated in the Indian schooling system for over three decades now. While India has been on a rapid expansion in secondary education, there have been certain issues that have often been debated upon and at times even criticized like the quality of the schooling system, inadequate infrastructure, the increase in demand for private schooling, poorly trained teachers etc. Almost all of these issues have been widely researched. The new policies that are being formulated are being largely attuned to the findings of these researches and ruminative measures suggested. One such area which is being largely contested upon is 'private tutoring' or 'the shadow' education system. The reason many educationists wish to study this from a policy and administrative management point of view is because there has been an exponential growth in the number of tutoring institutions in the country. Though private tutoring system is spreading to rural areas too, it is mostly present in urban centers. On one hand it has provided an increased income to a few, employment to the unemployment and scaffolding to the academically weak students. Alongside, it has also created an industry whose large revenues often remain unaccounted for. The policy makers and administrators seldom address this self evident industry. Schooling and private supplementary education both have bidirectional effects on each other which are rarely addressed. Even the inequalities that they promote supplement each other. The gender, cultural, regional, financial and caste based inequalities that private tutoring intensifies are ignored while administrators are busy addressing equity issues in formal schooling setup. The cross-national data on private tutoring is not very easy to explore and compile due to the difficulty in collecting information from so many different sources like teachers, parents, students, tutors etc. Also, the differences in definition makes it difficult to comprehend in many cases (Bray, 2010).

Although taking tuitions has become a trend in almost all classes in the Indian society, here we work on premise that

1. incidence of private supplementary tutoring would be relatively low amongst government schools students, since these supplementary institutions require a very high fees paying capacity.
2. the incidence of private supplementary tutoring would be relatively high amongst students studying in private schools since most of their parents would have a relatively higher capacity to afford high fees of these supplementary institutions.
3. Lastly, the demand for private supplementary tutoring would be equal for both high end and low end achievers.

Moving on, students living in and close to urban centres are the ones that are most exposed to this institutionalised private supplementary industry. The tutoring classes play with the insecurities of parents creating a fear that their child might fail to fulfill their expectation without outside scaffolding. With its huge contestations, it is difficult to find whether it is a demand driven supply or a supply driven demand. It is in this context that the study fits into the demand for exploration of parental and children's opinions on the need and scope of private tutoring in a metropolitan city like Delhi.

Defining Private Supplementary Tutoring

Private tutoring derives its principle from being an activity for private gain, specially financial gain for the tutors and also because it is a personal decision to provide and receive classes in a location agreed upon by both parties i.e. the tutor and the tutee/s. Bray(1999) through his reports shows that if at all this systematic system of education were given the right to award degrees the schools would eventually be extinct. In most of the present day work, supplementary private education and private tutoring are generally used synonymously. In order to understand private tutoring better it is important to understand the distinction between the two. Private tutoring or shadow education has emerged as a provision to compliment the present day school education rather than replace it. Tutoring is provided by full time tutors, school teachers, university students, retired teachers, university professors in support of a fee. The scope of this shadow system has grown so big that now schooling and tutoring have become complementary 'public private partnership'. The private tuitions are considered as centers of assisted learning which are often not accountable for the development of a child. They provide scaffolding for the child to achieve better grades in school or entrance examinations to higher education institutions. The private tutors are not expected to have a compulsory qualifications or pedagogic skills. The child is not expected to get educated just by going to these centers regularly and no effort is made to develop the child's personality. Private tuitions focus on acquiring skills for difficult subjects like learning tricks and shortcuts for solving mathematics problems. Also, areas like music, dance, theatre etc. are often left out of its purview. A student might access individual face to face tuitions, or tuitions in groups; home tuitions, or tuitions

at coaching centers; online tutoring or tutoring on phone or television. Shadow education is thus a means to only to gain skills for a purpose like cracking entrance exams or getting higher score in a test.

On the other hand, it has also been noted repeatedly (like in PISA scores and ASER reports) that the Indian schooling system has somewhere failed to provide conceptual understanding to children and there are various reports on its efficiency. It has long been condemned for its poor quality and lack of personal attention to children who fall behind the rest. When parents and students want support or scaffolding at the school level in order to bring the student at par with the rest or to excel academically, avenues for private tuitions are the only options left to explore. It is called 'Shadow system' because it mimics the formal schooling system. Also, the metaphor 'shadow' derives its existence only because there is an institutional school setup. The scope, extent and syllabus of this practice (the shadow) changes with any change in the public schooling system (Bray, 1999). Private supplementary tutoring on the other hand is an addition to the knowledge provided at the school level. It supplements the school education to give the child an edge over the rest so as to become a more appropriate match for entry into higher educational institutions eventually leading future job selection process.

Method

Research Methodology adopted

Sampling Technique

The 60 students coming from two different type of schools: 30 from government (public) and 30 from private school were given the questionnaire as shown in figure 1. As for in-depth interviews - Since, the opinions of all children and their parents were required, (whether they are accessing private tutoring or not), the selection of 40 student participants and their parents was based on convenient (non-probability) purposive sampling. Hence, the participants and sites which were "information rich" were selected from amongst all questionnaires received.

A total of 60 children, 30 each from government and private schools were selected for the study. Out of 30 sample students from each school, 10 students were from non-medical, 10 from medical and 5 from arts/humanities and 5 from commerce stream were selected for the study. In-depth interviews of students in any stream who take any form of supplementary tutoring along with their parents were further taken. Also, only 1 student who did not access any form of private tutoring and was interviewed along with his parents to gain insights on what influenced their decision to digress from the popular trend of taking tuitions. Besides, 2 private tutors involved in supplementary tutoring industry and 3 regular school teachers of higher secondary school were interviewed. The research included a teacher who was both a regular school teacher and a private tutor (on condition of confidentiality).

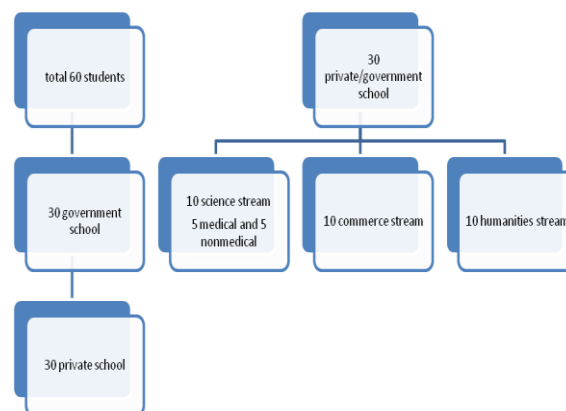

Figure 1. Students participating in questionnaire

Data collection Tools

The questionnaire had details related to the forms of tutoring they accessed, the time they spent on tutoring, subjects it was used for and finally if they found tutoring to be a burden. For children who had not enrolled in any form of tutoring a different section constituted questionnaire related to their perception on tutoring, if at all

they got academic assistance from any other source, the time they spent on studies and lastly if not having tutoring has benefitted them academically. The questionnaire was administered without presence of any teacher or school leader. Each question was explained in details after a preliminary explanation of the need and scope of the study. Children voluntarily agreed to be a part of the study and no child was under any obligation to cooperate with the researcher.

The questionnaire was only a means to approach children, make them aware of the research design. The researcher approached their parents and also gave them a basic idea of the objectives and scope of the research. The information children possessed regarding the research helped convince their parents to participate in the research. Almost all parents who were approached, agreed to become a participant. The semi-structured interviews were administered in the safe environment of the children's homes. The parents were requested for giving consent to record the interviews.. The semi-structured interview schedule gave the researcher flexibility to probe the parents and also triangulate data during the data during the interview process.

Profile of the Students

Table 1. Characteristics of the Students Participating in semi-structured interviews

Characteristics	Frequency	Percent(%)
Gender	Female	24 60
	Male	16 40
Participation in form of tutoring	In Tutoring only	26 65
	In Supplementary tutoring only	8 20
	In Both	5 12.5
Subject Stream	Medical	8 20
	Non-medical	8 20
	Commerce	12 30
	Humanities	12 30
Grade	XI	10 25
	XII	30 75
Number of siblings	Only child	3 7.5
	One sibling	22 55
	Two siblings	13 32.5
	Three siblings	2 5
School Type	Government	20 50
	Private	20 50
Self-assessed academic achievement	Very low	0 0
	Below average	3 7.5
	Average	10 25
	Above average	21 52.5
Ethnicity	Excellent	7 17.5
	Delhi	15 37.5
	Bihar	10 25
	Rajasthan	4 10
	Uttar Pradesh	9 22.5
Uttarakhand	2 5	

The table gives details of the cumulative data collected from the students using the questionnaire schedule, here the total sample size is 40. Out of the entire sample 40% were male students whereas 60% were female students. Nearly 65% of students (from all streams namely 40% from science streams , 20% from commerce stream and 20% from humanities stream ; 50% from government school and 50% from private schools) were accessing private tuitions where they were taking coaching for the same curriculum as the school. 20% students accessed private supplementary tutoring for preparing for entrances, having syllabus much cognitively higher than school curriculum. 12.5% students accessed both tutoring for school curriculum and tutoring for entrance tests. 75% students were from XII grade whereas rest 25% had to be taken from XI grade because schools had practical exam and less students were free to take the questionnaire. Most of the participant students had one more sibling i.e. where a family of two children(55%) whereas families with four children constituted only 5% of the sample. North West Delhi was the site of the both the schools which has a majority of migrant population leading to the diverse nature of regional variations in the sample as well. Most participants participating in the

study were either from UP (22.5%) or Bihar (25%). 52.5% students believed themselves to be below average achievers. None of the students rated themselves as low performers while 17.5 % rated themselves academically excellent.

Table 2. Characteristics of Parents of Students participating in semi-structured interview(data collection process)

Characteristics	Frequency	Percent(%)	
Children's Participation in form of tutoring	In Tutoring only	26	65
	In Supplementary tutoring only	8	20
	In Both	5	12.5
Children's Participation in Tutoring	Participation	31	77.5
	Non-participation	9	22.5
Participation in Supplementary Tutoring	Participation	8	20
	Non-participation	32	80
Non participation in any form of shadow education		1	2.5
Subject Stream of child	Medical	8	20
	Non-medical	8	20
	Commerce	12	30
	Humanities	12	30
Mother's education level	Not completed primary education	10	25
	Completed primary education	16	40
	Completed school education	4	10
	Completed degree	5	12.5
	Completed professional degree	3	7.5
Father's educational level	Post-graduate or above	2	5
	Completed professional degree	5	12.5
	Completed degree	15	37.5
	Completed school education	7	17.5
	Completed primary education	4	10
Household Monthly income	Not completed primary education	5	12.5
	Completed primary education	4	10
	Completed school education	7	17.5
	Completed degree	15	37.5
	Completed professional degree	5	12.5
House ownership	Post-graduate or above	4	10
	Below 10,000 rupees	2	5
	10,000-25,000 rupees	12	30
	25,000-50,000 rupees	11	27.5
	1lakh- 2 lakh	10	25
Level of satisfaction with Children's performance at school	more than 2lakhs	5	12.5
	Self ownership	12	30
Level of satisfaction with Children's performance at school	Rented	28	70
	Very dissatisfied	1	2.5
	Dissatisfied	2	5
	Neutral	18	45
	Satisfied	15	37.5
Very satisfied	4	10	

The Table 1.2 gives the profile of the students collected while interviewing the parents of the selected students. 40 parents provided their perspectives on the need and impact of private supplementary tutoring. The first section is the same as the input in Table1.1. The second section describes that 77.5 % participants' children took private tutoring for only the school curriculum and rest 22.5% constituted participants' whose children either

accessing private supplementary tutoring for entrance exam preparation or did not access any form of tutoring. Similarly, only 20% parents listed that their children only accessed private supplementary tutoring for entrance exam preparation. The rest 80% students either accessed private tutoring for school curriculum or no tutoring at all. Only 1 student did not access tutoring in any form: be it for school curriculum or entrance preparation. The data revealed, out of all the parents who participated most mothers(40%) had completed primary education only, whereas most fathers(37.5%) had completed their graduation degree. Most households (30% + 27.5% + 25%= 82.5%) had household income ranging from 25 thousand INR to 1 lakh INR. Nearly 45% parents were neutral with the participation of their children at school and 37.5% said that they were satisfied with performance with their children. Most parents when interviewed believed in to cognitive capacities of their children and were of the opinion that the children could do much better with a little more sincerity and effort.

Results and Discussion

Firstly a total of 60 students, 30 from government school and 30 from private school were given a preliminary questionnaire to gather some baseline data. The data revealed that nearly 98% students(59 out of 60) received some or the other form of private tutoring in the last six months. Nearly 25% students accessed private supplementary tutoring in institutional setups, where 5% of them took both private supplementary tutoring as well as private tutoring. The data revealed that almost all students in science sections(medical and nonmedical) in both schools received private supplementary tutoring in some form to prepare for approaching entrance tests. Over 70% students spent more than 4 hours each week in receiving private tutoring. In both schools with more than 7 hours invested in going schools, the burden on students increased heavily due to private tuitions after schools. Most students received tutoring in more than two subjects per week and during examination time spent nearly 20hours per week in private tutoring. All students accessing private supplementary tutoring spent 12-15 hours each week during normal school days in receiving tutoring for entrance exams. Given that students were under a lot of pressure for studying and attending private tuitions, yet only 20% of them believed that tutoring imposed a heavy burden on them, one third of students felt that tutoring was a fairly light. Most parents spent 10-20% of the household income for their child's education, this expenditure increased to 35% in certain cases.

All science stream subjects are most popular for taking private supplementary tutoring. Mathematics, Chemistry, Physics, Biology, English, Psychology and Accounts are the most popular subjects for taking private tuitions in groups or at home. The greatest proportion of tutoring was received by professional tutors; followed by teachers from other schools; and housewives in very few cases. In one case the school teacher himself was providing tuitions at his own residence. The 'stars' teachers were highly preferred professional tutors who provided classes in coaching institutes as well as expensive home tuitions for both supplementary and regular school tuition purposes. The students accessed supplementary tutoring mainly for scoring better ranks in entrance examinations like the NEET or AIEEE or CLAT. Private tutoring was mainly accessed for improving their grades and prepare for school examinations or board examinations(in case of XII grade). The examination centric school education system, less time for course completion, frequently changing teachers and low conceptual understanding were main factors for which students accessed one or more forms of tutoring. The anxiety of lagging behind and not getting admission in a good higher education institution fed in the insecurities of parents forcing them to invest in private tuitions. Tutoring for students in government school was also due to feeling of lagging behind and low confidence level to raise question in class. Tutoring also served as a way to socialize, gain confidence and assert the 'affordability' of parents to maintain social status in the society.

The only student not receiving any form of tutoring was studying in a private school with commerce stream possessing the cultural capital and had guidance available from his parents. Also, the parent's disbelief in tutoring system and will to invest more time in guiding the child made the child confident to not access tutoring in any form. The type of tutoring a child accessed mostly depended on the economic capability of the household, the opportunity cost involved, the educational qualification of the parents, school quality, location of their house and the student's academic background.

The Four Major Determinants of need of Private Supplementary Tutoring

System level factors

a. Economics- Delhi has become a quiet economically developed society in the past decades. A lot of people have migrated to here in search of better jobs. The boom in the software industry in NCR region has also contributed to the rise in salaries of people. Thus helping to increasing the affordability and living standard of

Delhites. With families getting nuclear, both parents earning, lower number of siblings and a urge for socio-economic mobility the investment to education has increased many folds over the past decades. With the growing demand for tutoring and the flexibility of tutoring hours many individuals(qualified and unqualified) have now started to opt for tutoring as a profession. Given that the school hours are only till the afternoon, the teachers now opt to take tuitions in their 'free time' as it supplements their income with very little or no investment.

Similar to the post Soviet era where "new socio-cultural realities of new democracies market economies"(Silova,2009, p.35) , the new market economy in Delhi too has changed people's outlook towards education. The higher rates of disposable income available with parents and the growing competitiveness in entrance examinations, have greatly encourage the supplementary tutoring industry. Supplementary Tutoring is viewed as a freely available commodity in market which parents want to arrange for their children to achieve excellence and better labor market opportunities.

But in the process of economic growth it has been noted that many a times the development is uneven. There are huge income disparities and differences in available educational resources in schools. There are elite private school, private schools for the middle class, low fee paying private schools and government school(which are also often categorized based on region and merit); further deepening the differences in educational opportunities through quality of schooling. Tutoring too has various layers depending on the fee paying capacity of the parents, making it tough for the economically weaker students to get the required benefits. Also, schools and tutoring centers often promote meritocracy for their rise in enrolments leaving behind the low achievers to be at a greater disadvantage.

b. The education system- With the less number of high paying jobs and fight to excel in labor markets the cream from best colleges across the country are usually hired, leaving out the mediocre and low performing students. The screening process to the universities in getting tough with the increasing massification of school education leaving parents with no choice but to help their child be the 'best'. Parents at a pan India level wish for their child to be a high achiever irrespective of the 'cost' incurred. A teacher's performance is judged based on the meritorious students it can produce and hence incentivized based on the students who get promoted to the 'elite' institutions in the country. This has to somewhat pushed the teachers and school authorities to pressurized the students to perform the best in the entrance test at any cost. The curriculum reforms often recommended by educationists and academicians can do little good in these conditions. Often households or family members are forced to migrate to cities in hope of getting better education(especially better supplementary tutoring facilities like in Kota) so as to help their children get smooth access to the best universities and colleges. This is both an affordability and accessibility issue. Many students and parents find it very difficult to approach the teachers with their doubts, forcing children to attend tutoring services to get better conceptual understanding. The teachers too are seldom have a fear of being penalized for forcing children to attend tutoring or providing tutoring themselves. This can be correlated with poor implementation of laws(like RTE,2009) and poor leadership in schools. Alongside, the respect for teaching profession and adherence to teacher ethics is low even among teachers themselves.

c.Traditional Indian culture- The social values in the Indian culture are highly judgmental of parents not investing to the fullest in their child's education, even when it may put them in debt or under a threat of bankruptcy. The value for education has been supreme in religious Indian texts and mythology and each individual needs to go to any lengths to be excellent in his field of study. The drilling and rote memorization is deeply embedded in the ancient Indian beliefs, right from reciting mantras to now learning formulas. The supreme importance of teachers and their unquestionable authority has led parents to tolerate unethical and unjust practices of teachers and school leadership.

d. Reduction in the number of children- With the rise in nuclear families the parents are finding it difficult to support and take care of many children. This gives them greater disposable income to get the best possible facilities for their one or two children. In families with greater number of children too, parents only wish to invest in the education of the 'brightest' child who has greater chances of success than the rest of the children. With the decreasing family size, the expectations of parents have increased and extensive parenting styles have started to gain prominence in most parts of India, especially urban setups. These investments included greater access to private supplementary tutoring.

e. Emerging social culture of Competitiveness- High levels of uneasiness and anxiety have been noticed in the parents and the children during the various interviews sessions. The parents are deeply concerned about their children 'lagging behind' the rest if they are not competitive enough. There is huge prevalence of social

competitiveness by comparison with peers, neighbors, relatives and friends. The performance of their children is a high area of discussion while attending any social event, making private supplementary tutoring a means to reduce the chances of 'failure' for the entire household.

Institution Level Factors

a. school related factors- The quality of school education is a derivative of the school policies and school culture. In a setup where the school leaders and teachers promote on high achieving students, the school culture becomes the one favouring only meritocracy. In private schools the pressure on children is higher. This is so because the enrolment of children in the schools is dependent on the extensive advertising based on the alumnus who have secured highest ranks in entrance tests. The school leaders are responsible for helping the enrolments grow which leaves them no choice but to adopt mechanisms like enrolling students who are high achievers only. The school leaders often favoured the science stream students as compared to students of other streams, For example the private school in the study only admitted students with 85% or above in Xth board examinations their science sections, 80% above in commerce and 70% above in humanities. The teachers in science sections were better paid(though not officially but through incentivisation) and extra classes were arranged for students in science sections during summer vacations and holidays. The EWS students were only admitted in the school if they had the required percentage(which had to be preferably higher as compared to fee paying students). The humanities section often suffered from teacher absenteeism and involvement of their teachers in other non-academic duties, this hampered their presence in classroom and focus on teaching.

Large class size in both government as well as private schools made it more difficult to have good learning environment and one to one interaction. For the lack of conceptual clarity in huge classes one of the students who knew his physics teacher personally received one-on-one tutoring as his teacher's house after school hours. The teachers and students both reported that often students did not pay much attention in class as they presumed that they would not understand anything or were too tired after the extensive supplementary tutoring center after school hours each day. The students often reported that the teacher's teaching style was such that did not give them 'correct and to the point answers' to the kind of questions asked in entrance examinations, which is why they preferred attending private supplementary classes.

b. tutoring companies related factors- the demand for supplementary tutoring was often created by extensive advertisement by the marketing staff of supplementary tutoring centers. The staff often misguided students as they were reported to use fake promises and at times even corrupt practices to include photos of the toppers of entrance examinations portraying them as their students. Often certain coaching centers incentivized teachers for promoting them by providing free teaching material or even promising good tutoring opportunities. Thus, the demand for supplementary tutoring as well as regular tutoring was often created by tutoring companies by using corrupt business expansion practices as well.

Household Factors

a. Family socio-economic status- The choice of tutoring institution was majorly related to the household income, the parent's educational level and disposable income available for tutoring. The students of socio-economically better off families wanted to get admission to elite educational institutions to maintain the culture of meritocracy in the family, whereas the children from socio-economically weaker families aimed at upward social mobility. Students of the EWS category studying in private schools got motivated after seeing the standard of living of other fee paying students and wanted to perform their best to achieve that lifestyle themselves.

The children whose parents could not afford tutoring in high end supplementary tuition centers often accessed cheaper versions like tuitions at the tutors' home or smaller tuition centers with lower quality. Contrastingly, certain parents who could afford a rather higher luxury, arranged for private supplementary tuitions at the house at an hourly basis.

b. Parenting style- Parental style was studied through analysis of the expectations of parents from their children, alongside their involvement in the child's education. While parents having lower economic capacity often expressed themselves as being helpless in providing input in the child's education, including choice of stream and private supplementary center(due to the lack of awareness and knowledge); parents with better socio-economic standing often chose the best possible private supplementary tutoring center for the child's

education. At times parents invested in different types of private supplementary tutoring based on the economic capacity and need of the child. It involved access to both institutionalized private supplementary tutoring and one on one home tutoring. The parents of only child who was not receiving any form of tutoring also expressed deep concern and rather greater involvement in the child's education, to the extent that they even taught him at home on a regular basis.

The parental control strategies that parents employed in keeping the child disciplined and focus for performing well was very much visible across all social classes. Keeping the economic constraints aside, the urge for meritocracy was similar for all parents. The intense parenting styles reflect the competitive nature of educational system and the society at large, the deep seated anxiety (also referred by Bray & Lykins,2012) is thus visible in this study as well.

c. Individual perception on effectiveness of tutoring- The individual perception of tutoring is also very much related to the extensive parenting styles and maintaining regularity in studies. Most parents believed that private supplementary tutoring helped the students be focused and motivated for performing well. Even in cases where children only went for regular school curriculum tutoring parents believed that it was a way to keep children away from their mobile phones, provide confidence of travelling alone and meeting new people. Students believed that tutoring helped them clear doubts that they could not ask in school; gain access to the kind of questions asked in boards and entrances; meet new friends; be engaged in competitive setup and develop confidence of performing well in pressure situations.

Student Individual Factors

Private supplementary tutoring mostly served the high achievers which often deepened the achievement gap at school. The students who had confidence of performing well in XII boards and wanted to get admission to elite professional programs usually accessed private supplementary tutoring classes. These students aimed at getting smooth access to labor markets and either maintain or move to higher socio-economic class. Low achievers on the other hand usually opted for private tutoring needed restricted to school curriculum. In one case even when he joined private supplementary tutoring(due to parental initiation) he left it midway due to inability to cope with the pressure.

Also, it was found that when students wanted to join family business, they still aimed at doing BBS/BBM/MBA from elite colleges and were ready to take-up crash courses even after boards for secure a rank in the entrance. They wanted to get into elite colleges as they believed that it would enhance their social standing. A degree from the topmost B-School would guarantee them better financiers for their business and make them praiseworthy in social gatherings. The student level factors responsible for choosing certain kind of tutoring often overlapped and reinforced society's urge for meritocracy in most cases.

Impact of Private Supplementary Tutoring on the Academic Achievement of Students

The initial aim of the study was only to examine the impact of private supplementary tutoring on the academic achievement of students. Through the course of study a few other impacts have also been uncovered. Private supplementary tutoring in Delhi has been an enrichment strategy for the already privileged households. The students already possessing the required economic, cultural and social capital were the ones who have benefitted the most from the tutoring systems. The affluent families have often shown a desire to maintain their status and their children have been best performers in most examinations. The competitive edge that these privileged children seek to maintain was much higher as compared to children of low income families. Children from low income families also have a self evident urge to perform better and change their social realities. For this the households try to find rather affordable solutions to provide this supplementation for entrance examinations. The cost effective tutoring they have access to is often of sub-standard quality. Some families are often forced to resort to private supplementary tutoring under peer pressure. The school type and stream opted were often the strongest determinants of the access to private supplementary tuition centers. The well to do students in private schools accessed supplementary tutoring at high-end institutionalized chains, whereas EWS category students and students studying in government schools often resorted to group tuitions at the tutors house or at small coaching centers. Supplementary Tutoring seemed to further marginalize the already disadvantaged students.

The widespread manipulation of teachers was evident in the study where to reduce their own burden teachers often prompted students of going to private tuition centers. On the pretext of being over-burdened they often

shunned away from their primary responsibility of teaching and helping students grow at a personal level. Though the teachers claimed that preparing for entrances was not the goal of school education and should not be their primary responsibility, they forgot their holistic role of a facilitator for children's best futures, rather than simply being agents of delivering the school syllabus. School leaders too did not take it up personally to help children overcome the phobia of entrance examinations and keep teachers accountable for their quality teaching. The school leaders too wanted to show off more number of selections from their institution even when the families had to pay a very heavy price for it. Often low achievers suffered from neglect and rejection leading to low self esteem with teachers and principals only favoring the high achievers who would eventually get good rankings in entrance examinations. The increased the institutionalized corruption at the level of school and tutoring institutes both.

The alarming impacts of private supplementary tutoring were often ignored by households which would have wide repercussions for the society as a whole(Bray,2003). The balanced and sustainable development of mainstream education suffered a lot due to proliferation and uninterrupted access of the private supplementary tutoring institutions. There was often a conflict between what was taught at school and tricks taught at private supplementary tutoring, this added to confusion for the already pressurized child. The main sufferers of this was the low achievers, they already struggled to understand basic concepts at school and now they were over pressed to rote memorize tricks and techniques needed to crack entrances. For most students the performance deteriorated in XI grade as the subject streams got diversified and the course burden increased. The added burden of attending private supplementary centers(that had no link to school curriculum and had a totally different aim and techniques of teaching and learning) made performance deteriorate for most children.

The immediate impact of the private supplementary coaching was often confusion, chaos, over burden and loss of self esteem among students especially the low achievers and students from economically weaker sections.

Conclusion

The research tries to unwrap the demand for private supplementary tutoring as perceived by the parents and students; and the impact of accessing these tutoring services on the academic achievement of children. The study conducted was empirical in nature and tried to involve the main stakeholders involved. It was found that majority of students in both government and private schools, studying in higher secondary classes were involved in accessing some form of private tutoring: be it for the greater conceptual understanding of school curriculum or prepare for entrance examinations. The consumers of private supplementary tutoring were mostly students preparing for entrance test to universities. Almost all science students aiming to get selected to engineering and medical colleges were major consumers. Additionally, students preparing for law entrances, entrances for English honours. CATE exam and children aiming to sit for Chartered Accountant levels accessed private supplementary tutoring, which were definitely lower in number as compared to science stream students. This was because most professional colleges in India require students to sit for entrance examinations irrespective of their score in XII grade(though minimum eligibility is usually 60% in XII boards). Whereas students applying to other non-professional courses in government colleges get admission through XII board examination percentages. It is rather contradictory to see that children do not want to study in government schools due to their perceived low quality, but want to get into prestigious government colleges due to the low fees and higher returns to education.

The study provided evidence for the increasing number of supplementary tutoring centers to be both supply driven and demand driven. The parents believed that by investing in tutoring facilities they are ensuring that their child performs well and gets a smooth access to labor market. At times parental investments fail due to high pressure on children and limited number of seats in elite colleges. The social, personal and school level factors are often responsible for opting for tutoring.

Though the study concentrated on private supplementary tutoring, which is tutoring provided to supplement school knowledge for better performance in entrance tests; the experiences on field promoted the researcher to also include aspects from private tutoring in general. The researcher included participants from all streams to eliminate any biases related to private supplementary tutoring only being available for students of the science stream. Which was found to be beneficial as emerging private supplementary centers for CLAT, CA and CATE entrances were also found. Parents of commerce students expressed their will of enrolling their child in 1 month long crash courses for BBM and BBS entrances after the class XII boards in March, as the entrances are in May.

The findings reveal that supplementary tutoring has not been much beneficial to students unless they actually sit for entrance tests as the knowledge gained at these centers is different in nature and purpose, it is seldom used in school examinations. Rather it was found that attending long duration classes at private supplementary centers hampers the self study time and leisure time of the children. They are often not able to take part in any social activity for fun due to being over-burdened with two separate course materials(of school and supplementary tutoring). It is also to note that the impact of supplementary tutoring and tutoring at large cannot be put into water tight categories. Both kinds of tutoring as accessed by children for difference reasons and study of the entire shadow education industry is impossible without studying the their impact collectively.

The study also helped gain a deeper understanding of school culture and advocacy of meritocracy. It showed the socio-economic disparities and deepening of inequalities through access to differentiated educational resources. The right of each child to gain quality education and development of individual capabilities has been a question that we need to answer as an educational community.

Acknowledgements

The paper is an outcome of the author's Masters of Philosophy(M. Phil 2017-19) research work carried out at National Institute of Educational Planning(NIEPA), NewDelhi, India. The author expresses her gratitude to her institution and her research guide Dr. N.K Mohanty for providing his constant support and guidance.

References

- Aurini, J., & Davies, S. (2004). The transformation of private tutoring: Education in a franchise form. *Canadian Journal of Sociology/Cahiers canadiens de sociologie*, 29 (3): 419-438.
- Bray, M. (1999). *The shadow education system: Private tutoring and its implications for planners*. Paris: UNESCO International Institute for Educational Planning (IIEP).
- Bray, M. (2003). *Adverse effects of private supplementary tutoring: Dimensions, implications and government responses*. Paris: UNESCO International Institute for Educational Planning (IIEP).
- Bray, M. (2009). *Confronting the shadow education system: What government policies for what private tutoring?* Paris: UNESCO International Institute for Educational Planning (IIEP)
- Bray, M. (2010). Blurring boundaries: The growing visibility, evolving forms and complex implications of private supplementary tutoring. *Orbis Scholae*, 4 (2): 61-73.
- Bray, M., & Lykins, C. (2012). *Shadow education: Private supplementary tutoring and its implications for policy makers in Asia*. Hong Kong: Comparative Education Research Centre(CERC)and Mandaluyong City: Asian Development Bank.
- Bray, M. (2013). Benefits and tensions of shadow education: Comparative perspectives on the roles and impact of private supplementary tutoring in the lives of Hong Kong students. *Journal of International and Comparative Education*, 2 (1): 18-30.
- Buchmann, C. (2002). Getting ahead in Kenya: Social capital, shadow education, and achievement. In B. Fuller, & E. Hannum (eds.), *Schooling and Social Capital in Diverse Cultures*. Amsterdam: JAI Press, pp.133-159.
- Diskin, K. S. (2010). *Private tutoring: An intersection of economic interests and social capital*. PhD thesis, Walden University.
- Foondun, A. R. (2002). The issue of private tuition: An analysis of the practice in Mauritius and selected South-East Asian countries. *International Review of Education*, 48 (6): 485-515.
- Ireson, J. (2004). Private tutoring: How prevalent and effective is it? *London Review of Education*, 2 (2): 109-122.
- Kim S., & Lee, J. (2010). Private tutoring and demand for education in South Korea. *Economic Development and Cultural Change*, 58 (2): 259-296.
- Paviot, L., Heinsohn, N., & Korkman, J. (2008). Extra tuition in Southern and Eastern Africa: Coverage, growth, and linkages with pupil achievement. *International Journal of Educational Development*, 28(2): 149-160.
- Silova, I. (2010). Private tutoring in Eastern Europe and Central Asia: Policy choices and implications. *Compare: A Journal of Comparative and International Education*, 40 (3): 327-344.
- Stevenson, D. L., & Baker, D. P. (1992). Shadow education and allocation in formal schooling: Transition to university in Japan. *The American Journal of Sociology*, 97 (6): 1639-1657.
- Sunderman, G. L. (2007). *Supplemental Education Services under NCLB: Charting Implementation*. Policy Brief, The Civil Rights Project, UCLA. October.

Author Information

Harshita Sharma

National Institute of Educational Planning and
Administration(NIEPA) 17-B, Sri Aurobindo Marg, NCERT
Campus, Katwaria Sarai, New Delhi, Delhi 110016, India
Contact E-mail: *harshita2792@gmail.com*

How Close Are Teachers to Think in a Scientific Manner?

Naz Fulya OZKARABACAK
Mugla Sitki Kocman University

Ayse OGUZ UNVER
Mugla Sitki Kocman University

Abstract: Lately, The Ministry of National Education (Turkey) has announced ‘2023 Education Vision’ for raising qualified generations equipped with a variety of skills and for meeting the needs of educators. Students, families, teachers and schools are four primary elements of the report. Especially upskilling teachers who appeal future generations and evaluating their skills are often referred in the report. In this regard, the present survey study aimed to determine and compare scientific thinking skills of teachers in accordance with their working experiences. Sampling of the study comprised of 62 teachers working in schools of Aegean region of Turkey from a variety of disciplines such as mathematics, science, and information technologies, and of working experiences from 1 to 28 years. Data of the study are gathered through sequential inquiry-based activity sheets administered simultaneously with the implementation of inquiry-based activities regarding electromagnetism. Findings of the study revealed that teachers had irrational and intuitive levels of thinking skills at the beginning and they could improve their level of thinking through activities and approached to think more in a scientific manner. However, this improvement differed as working experience changes. Novice teachers who have working career for less than 2 years could not show statistically significant improvement in their statements, in contrast, well-experienced teachers showed statistically significant increase in their scientific thinking scores. They could record their predictions and explanations consistently by considering variables, and evidence-data, they could make observations in an objective way which are the analyzing criteria determined by considering the literature. With the light of the findings, it is argued that especially novice teachers need support to improve their abilities and that they could be encouraged in a longer period with such inquiry-based activities fostering their thinking skills which eventually result in having scientific thinking generations as intended in 2023 education vision.

Keywords: Scientific thinking, Teacher experience, Evaluation, 2023 Education vision

Introduction

Attempts of understanding how an individual learns, proceeds the knowledge, decides on thinking pathways have been matter of interest amongst well known psychologists such as Piaget and Vygotsky who still enlighten today’s research. This endeavor seems to remain on agenda with the increasing needs of improving education standards. Emphasis of meeting desired standards are widely discussed across the world, both in reports of National Research Council [NRC], and of Organization for Economic Co-operation and Development [OECD].

In a national point of view, Ministry of National Education [MoNE] of Turkey similarly dwells on addressing those standards to keep in pace with the fast-developing world. Lately, MoNE has announced ‘2023 Education Vision’ for raising qualified generations equipped with a variety of skills and for meeting the needs of educators. Turkey’s results in Programme for International Student Assessment [PISA] tests and the latest OECD (2019) report highlight the importance of taking steps for improving the qualities of education. In the 2023 Education Vision Report, students, families, teachers and schools are presented as the four primary elements. The interrelatedness of those elements is underlined because of the fact that they all directly affect teaching and learning processes. Especially upskilling teachers who appeal future generations and evaluating their skills are often referred in the report. Providing well qualified pre-service and in-service education for

- This is an Open Access article distributed under the terms of the Creative Commons Attribution-Noncommercial 4.0 Unported License, permitting all non-commercial use, distribution, and reproduction in any medium, provided the original work is properly cited.

- Selection and peer-review under responsibility of the Organizing Committee of the Conference

teachers is stated to help fostering their teaching performance and thus students' academic development.

Skill acquisition these days come before solely memorizing of textbook information without any reasoning processes. It is believed by many researchers that skills are required to help an individual to see the meaning and worth of learning, and to reach full understanding of concepts. Scientific thinking skills which shaped existence and survival of many nations up till now is one of the thinking skills that are tried to be understood, improved and evaluated. The importance of the term 'scientific thinking skills' may not seem to be discussed as much as current focus on robotics and coding skills, or engineering and design skills addressed in STEM education, however, it forms a basis for those skill groups with regard to problem solving.

Societies needed to think scientifically even for hunting and gathering (Carruthers, 2002), making predictions and observations to raise and save their food, and maintaining welfare of their selves. 5 years lasting Halys Battle (28 th May 585 BCE) may be given as an instance regarding two scenarios in absence and presence of scientific thinking. The Halys Battle known as Battle of the Eclipse occurred around Halys River (Kızılırmak River of Anatolia). Battle between the Lydians and the Medes coincide with a solar eclipse according to Herodotus' recordings. 'The day was turned to night.' says, Herodotus and once seeing the sudden night sky, people quitted the battle because of thinking that gods were sending a message (Stephenson & Fatoohi, 1997). Thales of Miletos however, by doing accurate scientific observations and inferences, could predict the event and warned his people before it happens by pointing out that it is a natural phenomenon and there is nothing to be afraid of. This instance addresses the potential of scientific thinking on shaping the survival of communities.

Considering the related research on the literature, researchers compromised on the fact that scientific thinking skills are needed to be improved and fostered even today to help individuals solve daily life problems encountered, ask further questions, inquire, consider important factors and variables, explain concepts in a meaningful way, and reach the scientific knowledge and conclusions. Teachers take an important place in teaching-learning processes in which they help students learn and comprehend new concepts, relate new concepts with the pre-conceptions, use data and evidence to explain scientific phenomena, consider variables, in short; think in a scientific manner. In addition, related findings of the literature indicate that teachers, especially novice teachers either do not possess or cannot efficiently use their thinking skills and it mostly depends on working experience (e.g. Borko & Livingston, 1989; Darling-Hammond & Schlau, 1996; Fantilli & McDougall, 2009; Haynes, 2011; Karataş & Karaman, 2013; Kim & Roth, 2011; Mirzaei Phang & Kashefi, 2014; Zimmerman 2017). For instance, Mirzaei, Phang and Kashefi (2014) compared expert and novice teachers' levels of reflective thinking through the use of questionnaires. Mirzaei et al. (2014) emphasize the differences of levels of reflective thinking between novice and expert teachers and they determined which reflective thinking skills do they have and use such as observation, social communication and cooperation. By pointing out the weaknesses of novice teachers' reflective thinking processes, researchers suggest tools for the purpose of improving inadequacy of thinking skills.

To this end, especially novice teachers having two or less years of working experience need to be supported for being well-equipped with scientific thinking skills (Windschitl 2003; Zimmerman, 2017). Findings of the literature also suggests that the pre-service teachers are not very different from those teachers in terms of their lacking of adequate thinking skills (As' ari, Mahmudi & Nuerlaelah, 2017), thus, they also need such support (pre-service education and master's programs) before they start to appeal students.

Method

Research Design and Sample Group

The present study has cross-sectional survey design with the aim of determining and comparing novice and expert teachers' level of thinking skills. Sample group of the study is comprised of 62 teachers from variety of disciplines such as mathematics, science, primary school, information technologies, et cetera (see detailed information regarding the sample group in Table 1). Teachers working in schools of Aegean region of Turkey had working experiences varying from 1 to 28 years. Participants' experience levels are determined in such a way that teachers having two or less years of working experiences have been labelled as novice, and participants having more than two years of working experiences are accepted as experts (Haynes, 2011). Convenience sampling method is used for selection of participants because of their being easily accessible by the researchers.

Table 1. Frequencies concerning gender, disciplines and working experiences of the teachers

		Frequency (f)	Percentage (%)
Gender	Female	37	59.68
	Male	25	40.32
	Total	62	
Discipline	Science	31	50.00
	Mathematics	16	25.82
	Technology and Design	4	6.45
	Information Technologies	5	8.06
	Preschool	1	1.61
	Primary School	5	8.06
Working Experience	Novice (0-2 years)	21	33.87
	Expert (2+ years)	41	66.13

Data Collection Procedure

In the present study, it is aimed to determine and compare novice and expert teachers' level of thinking through implementation of sequential inquiry-based activities, data were collected in spring semester of 2018-2019 academic year and it lasted three months. Data were collected through inquiry-based sequential activity sheets designed in accordance with implementation of sequential inquiry-based activities. Participants filled 11 sequential activity sheets simultaneously with the activities. In these activity sheets, sections for participants' noting their predictions, observations, and explanations down are provided. Participants' statements are analyzed and coded with specified criteria.

Data Collection Instrument

Data of the study were gathered through the use of 11 sequential inquiry-based activity sheets on a popular yet not well-known subject, electromagnetism. Activity sheets are designed in such a way that they are administered simultaneously with the sequential inquiry-based activities regarding electromagnetism. The implementation of the sequential inquiry-based activities is also utilized as a 'tool' rather than an intervention. Participants' way of thinking when encountering series of discrepant events on a novice topic is tried to be understood and to be evaluated with specified qualities of thinking.

Sequential Inquiry-Based Activity Sheets

The first 10 activity sheets involved *prediction* section with multiple choices and one open-ended choice to ensure participants' expressing their thinking freely, open-ended *observation* and *explanation* section. They are asked to make scientific predictions before the demonstration of the sequential inquiry-based activities and justify their predictions by stating their reasons. After they state their predictions and justifications, they record their observations and based on their observations, they try to make interpretations to explain the logic behind the observed phenomena. In the last and 11th activity sheet, a table is provided for students so that they record and consider all their data (observations in our case) in a holistic point of view, and lastly a final interpretation section is provided for participants to let them compare data gathered and make inferences accordingly.

Analysis of Data

Statements on sequential inquiry-based activity sheets are both analyzed individually, focusing on a horizontal development and also intragroup comparisons between novice and expert teachers. For the analyses, SPSS (Statistical Package for Social Sciences) with descriptive statistics and inferential statistics test (Friedman Test) was used. Specified thinking levels are coded and labelled in SPSS as 1,2, and 3. It is mainly investigated whether participants think with variables, support their claims with evidence and data, and whether they justify their explanations in a consistent way. Based-on those requisites, statements of participants were coded under three main headings; *irrational thinking*, *intuitive thinking* and *scientific thinking* with the lights of related research on thinking skills (i.e. Kember et al., 2000; Korthagen, 2001; Perschbach, 2006; Husu Toom &

Partikanien, 2008).

Results and Discussion

In the present study, raised research questions are as follows:

RQ1-) In which way the levels of scientific thinking of teachers' change during inquiry-based activities?

Findings of the study revealed that in overall point of view, teachers had thinking levels between irrational and intuitive thinking at the beginning of encountering discrepant events and different variables of electromagnetism ($M = 1.82$), and they approached to think scientifically at the end of the activities ($M = 2.10$), and they had mean scientific thinking score of $M = 1.94$, $SD = .299$ (See Figure 1).

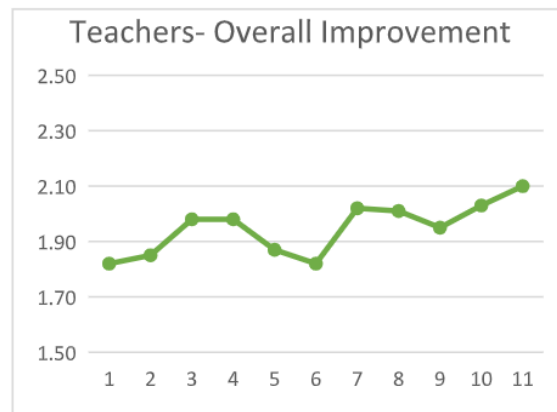

Figure 1. Overall improvement of teachers in their thinking skills

RQ2-) Is there any statistical difference of scientific thinking levels of participants (novice and expert teachers) in their predictions, observations and explanations through sequential inquiry-based activities?

Teachers showed statistically significant difference in levels of scientific thinking in their predictions through 10 sequential inquiry-based activity sheets $\chi^2(9, n = 62) = 578.31, p < .05$. Inspection of mean values showed an increase in level of scientific thinking from the first activity sheet ($M = 1.68$) to the 10th activity sheet ($M = 2.00$), they also showed statistically significant difference in levels of scientific thinking in their observations through 10 sequential inquiry-based activity sheets $\chi^2(9, n = 62) = 41.11, p < .05$. Inspection of mean values showed an increase in level of scientific thinking from the first activity sheet ($M = 1.85$) to the 10th activity sheet ($M = 2.03$), teachers also improved their explanations through 11 sequential inquiry-based activity sheets $\chi^2(10, n = 62) = 99.37, p < .05$. Inspection of mean values showed an increase in level of scientific thinking from the first activity sheet ($M = 1.98$) to the 11th activity sheet ($M = 2.10$). However, as findings revealed, these improvements depended on the working experiences of the teachers.

In addition to the teachers' overall improvement in their level of thinking (from $M = 1.82$ to $M = 2.10$), both novice and expert teachers' thinking improvement on activity sheets is analyzed horizontally with the Friedman Test. Findings revealed that novice teachers could not improve their level of scientific thinking in their predictions $\chi^2(10, n = 62) = 7.88, p > .05$, observations $\chi^2(10, n = 62) = 10.00, p > .05$ and explanations significantly $\chi^2(10, n = 62) = 11.89, p > .05$. However, expert teachers' improvement in level of scientific thinking on prediction ($\chi^2(9, n = 62) = 16.66, p < .05$ and observation ($\chi^2(9, n = 62) = 24.01, p < .05$) were statistically significant, improvement of expert teachers on explanations however, was not found to be statistically significant ($\chi^2(10, n = 62) = 17.51, p > .05$) (See Tables 2, 3 and 4).

Table 2. Improvement in thinking - predictions from the 1st activity sheet to 10th activity sheet

	N	3
	Chi-Square	7.744
	Df	9
	Asymp. Sig.	.560
0-2 years (Novice Teachers)	N	2
	Chi-Square	7.875
	Df	9
	Asymp. Sig.	.547
2+ Years (Expert Teachers)	N	20
	Chi-Square	16.663
	Df	9
	Asymp. Sig.	.054

Table 3. Improvement in thinking - observations from the 1st activity sheet to 10th activity sheet

	N	5
	Chi-Square	10.077
	Df	9
	Asymp. Sig.	.344
0-2 years (Novice Teachers)	N	3
	Chi-Square	10.000
	Df	9
	Asymp. Sig.	.350
2+ Years (Expert Teachers)	N	41
	Chi-Square	24.018
	Df	9
	Asymp. Sig.	.004

Figure 4. Improvement in thinking - explanations from the 1st activity sheet to 11th activity sheet

0-2 years (Novice Teachers)	N	4
	Chi-Square	11.892
	Df	10
	Asymp. Sig.	.292
2+ Years (Expert Teachers)	N	26
	Chi-Square	17.507
	Df	10
	Asymp. Sig.	.064

These data support the findings of related literature that expert teachers perform and improve their selves better on specific tasks when compared to novice teachers having two or less years of working experiences (e.g. Borko & Livingston, 1989; Darling-Hammond & Schlau, 1996; Fantilli & McDougall, 2009; Haynes, 2011; Karataş & Karaman, 2013; Kim & Roth, 2011; Windschitl 2003; Zimmerman, 2017). This finding may be interpreted as an urgent need for improving the pre-service and in-service programs to help novices keep in pace with the new trends in education (Huang, 2015). Consistent with the related research, expert teachers having more years of working experience, are able to modify and improve their thinking in a shorter time to more of a scientific manner. Considering their considerable impact on learning processes, especially for children in younger ages, scientifically thinking teachers are required for the aims and intended standards mentioned in 2023 Education Vision Report.

Last but not least, author, physicist and futurist Michio Kaku in his speech on ISTE 2016, warns people about the digitized future in which development of technology that human power will no longer be needed as much as today's, especially in medicine and engineering areas. However, Kaku underlines the fact that teaching profession does not seem to be disappear although with the improvements on technology, even in underdeveloped countries, people can learn through distant education. The reason of teachers' remaining on the agenda is that learners still will need to be guided and be supported to comprehend concepts, therefore teaching will change its form more into a guidance and facilitator, rather than a transferring of information as Kaku suggests. Considering Kaku's insights into future, the presence of scientific thinking teachers, guides, or facilitators seems to be crucial even more.

Conclusion

In sum, with the light of the findings of the study, it is concluded that:

- Sequential inquiry-based activities helped teachers getting closer to think scientifically.
- Expert teachers who have working experience more than two years showed more consistent improvement through the activities, when compared with novice teachers.
- Novice teachers who have working career for less than 2 years could not show statistically significant improvement in their statements on *prediction, observation and explanation sections*, in contrast, well-experienced teachers showed statistically significant increase in their scientific thinking scores.
- Especially novice teachers need support to improve their abilities and that they could be encouraged in a longer period with such inquiry-based activities fostering their thinking skills.

Future Research

In the future research, it is planned to compare of different participant groups in a longer period of data collection. Further, it is intended to investigate if other groups of skills addressed in the 2023 Education Vision are related with scientific thinking skills.

Recommendations

It is recommended repeating the study into other contexts (other participant groups or other concepts to be covered) in a purpose of increasing the validity of data collection tool.

References

- As' ari, A. R., Mahmudi, A., & Nuerlaelah, E. (2017). Our prospective mathematic teachers are not critical thinkers yet. *Journal on Mathematics Education*, 8(2), 145-156. Retrieved from <https://files.eric.ed.gov/fulltext/EJ1150240.pdf>
- Borko, H., & Livingston, C. (1989). Cognition and improvisation: Differences in mathematics instruction by expert and novice teachers. *American Educational Research Journal*, 26(4), 473-498. Retrieved from <https://journals.sagepub.com/doi/abs/10.3102/00028312026004473?JournalCode=aera>
- Carruthers, P. (2002). The cognitive functions of language. *Behavioral and Brain Sciences*, 25(6), 657-674. doi:10.1017/S0140525X02000122
- Darling-Hammond, L. & Schlau, E. (1996). Who teaches and why? Dilemmas of building a better profession for twenty-first century schools. In J. Sikula (Ed.), *Handbook of research on teacher education*. (2nd. ed., pp. 67-101). New York: MacMillan.
- Fantilli, R. D., & McDougall, D. E. (2009). A study of novice teachers: Challenges and supports in the first years. *Teaching and Teacher Education*, 25(6), 814–825. doi:10.1016/j.tate.2009.02.021
- Haynes, L. (2011). *Novice teachers' perceptions of their mentoring experiences* (Doctoral dissertation). Lamar University-Beaumont. Retrieved from <https://search.proquest.com/docview/922678446?pq-origsite=gscholar>
- Huang, J. L. (2015). Cultivating teacher thinking: Ideas and practice. *Educational Research for Policy and Practice*, 14(3), 247-257. Retrieved from <https://link.springer.com/article/10.1007/s10671-015-9184-1>
- Husu, J., Toom, A., & Patrikainen, S. (2008). Guided reflection as a means to demonstrate and develop student teachers' reflective competencies. *Reflective Practice*, 9(1), 37-51. doi:10.1080/14623940701816642
- Karataş, P., & Karaman, A. C. (2013). Challenges faced by novice language teachers: Support, identity, and pedagogy in the initial years of teaching. *The International Journal of Research in Teacher Education*, 4(3), 10-23. Retrieved from <https://dergipark.org.tr/download/article-file/90261>
- Kember, D., Leung, D. Y., Jones, A., Loke, A. Y., McKay, J., Sinclair, K., ... & Yeung, E. (2000). Development of a questionnaire to measure the level of reflective thinking. *Assessment and Evaluation in Higher Education*, 25(4), 381-395. doi:10.1080/713611442
- Kim, K. A., & Roth, G. L. (2011). Novice teachers and their acquisition of work-related information. *Current*

- Issues in Education*, 14(1). Retrieved from <http://cie.asu.edu/>
- Milli Eğitim Bakanlığı. (2018). *2023 eğitim vizyonu* Ankara: MEB. Retrieved from http://2023vizyonu.meb.gov.tr/doc/2023_VIZYON_ENG.pdf
- Mirzaei, F., Phang, F. A., & Kashefi, H. (2014). Assessing and improving reflective thinking of experienced and inexperienced teachers. *Procedia-Social and Behavioral Sciences*, 141, 633-639. doi:10.1016/j.sbspro.2014.05.111
- Organisation for Economic Co-operation and Development. (2019), *OECD skills outlook 2019: Thriving in a digital world*. Paris: OECD Publishing. doi:10.1787/df80bc12-en.
- Perschbach, J.W. (2006). *Blogging: An inquiry into the efficacy of a web-based technology for student reflection in community college computer science programs*. (Doctoral dissertation). Nova Southeastern University. Graduate School of Computer and Information Sciences: Florida.
- Windschitl, M. (2003). Inquiry projects in science teacher education: What can investigative experiences reveal about teacher thinking and eventual classroom practice? *Science Education*, 87(1), 112-143. doi:10.1002/sce.10044
- Zimmerman, A. S. (2017). Knots in thinking and the problem of enactment: Exploring the classroom thinking of three novice teachers. *Mid-Western Educational Researcher*, 29(4). Retrieved from <https://eric.ed.gov/?id=EJ1165681>

Author Information

Naz Fulya Ozkarabacak
Mugla Sitki Kocman University
Education Faculty, Mugla/ Turkey, 48000
Contact E-mail: nazozkarabacak@mu.edu.tr

Ayse Oguz Unver
Mugla Sitki Kocman University
Education Faculty, Mugla/ Turkey, 48000

The Eurasia Proceedings of Educational & Social Sciences (EPESS), 2019

Volume 13, Pages 24-36

ICRES 2019: International Conference on Research in Education and Science

M.I.S.O. – Motion In The Science Ocean - Erasmus+ project - Use of Powtoon, Easyclass and Mentimeter in a High School Debate using the the WSDC model

Luisa SANTOS

Agrupamento de Escolas da Maia

Neusa FERNANDES

Agrupamento de Escolas da Maia

Guilherme JORGE

Agrupamento de Escolas da Maia

Lucio MAGALHAES

Agrupamento de Escolas da Maia

Mafalda BROCHADO

Agrupamento de Escolas da Maia

Mariana REBELO

Agrupamento de Escolas da Maia

Miguel LEDO

Agrupamento de Escolas da Maia

Lara FERREIRA

Agrupamento de Escolas da Maia

Zenaida CODIA

Agrupamento de Escolas da Maia

Beatriz VILAS-BOAS

Agrupamento de Escolas da Maia

Abstract: SdDESM, “Sociedade de Debates da Escola Secundária da Maia”, is a local school debate society led by the actual student members, teachers and a teacher coordinator. Its purpose is to think critically about issues in logical and unbiased ways in order to provide solutions and debate them to find the best one, making students love understanding all viewpoints and perspectives, but also teach them how to criticize in a respectful and rational way. The main goal of this work was to train high schoolers from 6 countries involved in the MISO Erasmus+ Project (Romania, Germany, Spain, Norway, Portugal, Turkey) in the World Schools Debate Competitive Model (WSDC) skills and competences. One of the objectives of the Erasmus+ MISO project is to attract more students to science in general through new methodology using new ICT applications/ e-learning tools. The students used various digital tools such as Powtoon to do tutorials on the debate model, Easyclass to do a course (“How to debate”), and Mentimeter for evaluation of the international debate, with the motion “This House believes that overfishing and ocean pollution will compromise our survival on a long term basis” that took place in Maia High Secondary School, integrated in the Portuguese mobility in the 7th February 2019. This debate also met

- This is an Open Access article distributed under the terms of the Creative Commons Attribution-Noncommercial 4.0 Unported License, permitting all non-commercial use, distribution, and reproduction in any medium, provided the original work is properly cited.

- Selection and peer-review under responsibility of the Organizing Committee of the Conference

© 2019 Published by ISRES Publishing: www.isres.org

one of the project competences which is understanding scientific content and foster structured international cooperation objectives.

Keywords: WSDC, Science, E-learning tools, Education

Introduction

Why Debate

Debating or not debating may be the question! Some authors point out the debate as an "interesting-people-magnet" and a complement to the academic work improving the teaching-learning binomial, with positive impact on the school results, namely, in the way students analyze tests questions as well as the performance in an oral or written work, through the critical thinking learning ability and improvement of communication skills (Ferreira da Cunha, A, 2013).

Other authors reinforce the idea of substantial cognitive gains that students can achieve by engaging in participatory educational activities such as debate, pointing out to research developed by educational psychologists (Bellon, J., 2000).

Knowing how to listen and understand better, developing greater tolerance and increasing the ability to better understand the other's point of view are also pointed out as reasons for debating, beside the possibility of increasing the scope of knowledge with the topics debated and boost self-confidence (Ferreira da Cunha, A, 2013). Policy debate specifically teaches students to adopt multiple perspectives – one of the most important problem-solving skills (Bellon, J., 2000). From a point of view of classroom work, author Andrew L. Oros (2007) states that the use of structured discussions as a teaching strategy can increase the number of students who engage actively in a classroom discussion as well as the quality of their participation and, again, the significant improvement of students' marks on oral and written school work. The structured debate is thus seen like a tool for the development of critical thinking and for teachers to obtain more productive students participation in classroom environment.

About debating in an Erasmus+ project, we can use the statement of the International Debate Education Association (IDEA), which emphasizes that "Debates are a way of fostering international understanding, cooperation and the free and lively exchange of ideas". Also, IDEA, mentions that debate events can "offer much more than a mere contest of formal argumentation" and is important to note that debates can bring a significant connection between people of different cultures and backgrounds while exploring opposing perspectives.

WSDC Model

A debate is basically an "exchange of arguments between two teams" that approaches a topic from different points of view (Sanchez, 2012).

The WSDC (World Schools Debating Championship) format embodies a minimum of three speakers per team. There is a team known as the government (or affirmative) and a team known as the opposition (or negative). One team will propose a change in the *status quo*, whereas the other team is defending it with in a specific speaking order and speaking time for each team to conduct their speeches. The government presents the line of argumentation to the case and the opposition has to rebut and refute the arguments. Impartial judges (adjudication team) will evaluate the debate assessing the quality of the arguments used and other features as the originality and style of the speaker. The debate is governed by several rules. There are established time limits for the speeches, which cannot be interrupted without fulfilling various requirements (Sanchez, 2012). The adjudication team also have to ensure that the discussions take place in a non-hostile environment to any of the participants permitting to criticize in a respectful and rational way.

The *motion* or *resolution* is the given topic that is going to propose a change and usually starts with "*This House (believes, proposes ...)...*" The given motions must be balanced, that is, they must be debated with equal degree of difficulty for both sides.

Figure 1 depicts the layout of a debate using WSDC model according to Sanchez, 2012.

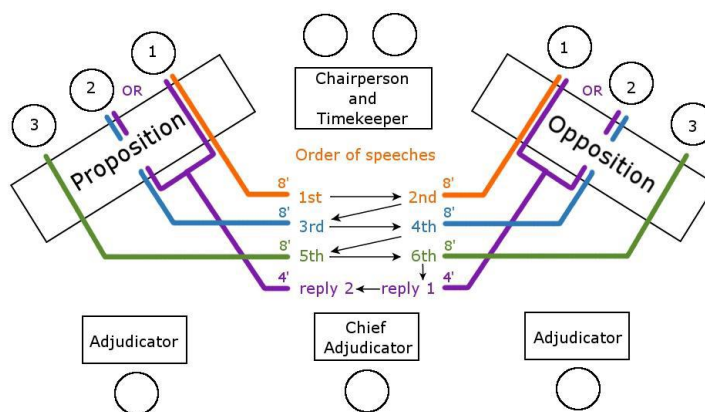

Figure 1. The debate layout (Sanchez, 2012)

SdDESM - Debate Society of Secondary School of Maia

SdDESM, “Sociedade de Debates da Escola Secundária da Maia”, is a local school debate society led by the actual student members, teachers and a teacher coordinator. At present this kind of club has eight student’s members of the secondary level and two teachers, one of whom is the coordinator. SdDESM members have a strong sense of group identity, like a symphony orchestra (IDEA).

The main purpose of SdDESM is to train students how to think critically about issues in logical and unbiased ways in order to provide solutions and debate them to find the best one, making students love understanding all viewpoints and perspectives, but also teach them how to criticize respectfully.

SdDESM works as an extracurricular activity (or club) and meets weekly to provide training and regularly debating, usually conducting two debates per year for the school community, one at the beginning of the school year to recruit new members and another one at the end of the school year. Students prepare training sessions for new members in collaboration with mentors of SdDUP – Debate Society of Porto University (<https://www.sdd.up.pt/>). Usually, the training programme has between six to nine sessions on the model of debate, the structure of the arguments and case analysis, speeches of prime minister and leader of the opposition, adjudication and motions.

The debate society is present in social networks (FB:@SdDESM; INST:@sddesmesmaia) and has a logo made by SdDESM students (Figure 2)



Figure 2. SdDESM logo (2014)

M.I.S.O. – Erasmus+ project

MISO is the acronym of a Key Action 2 project (reference number 2018-1-DE03-KA229-047185), implemented by Erasmus+ programme, that stands for “Motion In the Science Ocean” and involves six countries: Romania, Germany, Spain, Norway, Portugal and Turkey being Germany the applicant organisation. The target audience are the students of secondary level of this countries that were from very different backgrounds.

Key action 2 (KA2) is for cooperation for innovation and the exchange of good practises which is the main objective of MISO project.

According to the Erasmus+ programme guide (European Commission, 2019), these projects under KA2 are expected to “bring positive and long-lasting effects” on organisations and persons and to “result in the development, transfer and/or implementation of innovative practices” in which we can include debate.

Also, projects supported under KA2 should lead to several outcomes like “innovative approaches for addressing their target groups” and participatory approaches and ICT based methodologies which fit into the scope of this work as one of the objectives of the Erasmus+ MISO project is to *attract more students to science in general through new methodology using new ICT applications/ e-learning tools*.

The specific objectives of the Miso project clearly depict the guidelines of the Erasmus + programme and those in which the present work is supported are: a) *increase student interest in science in general and to increase student interest in science in mixed groups (with the help of e-learning tools); b) encourage continued professional development by teachers: share ideas and reflect more on their own teaching, incorporate new ideas and methods into practical teaching; (...)* d) *foster the use of ICT with different applications for experiments, communication, presentation; e) promote key competences, cross-subject competences and entrepreneurship ;f) motivate everybody taking part in the project to use foreign languages (English) as communication tools; g) foster structured international, cross-regional and cross-sectorial cooperation.*

The present work refers to the activities developed in the Portuguese mobility of the MISO project in February 2019. The debate is one of the methodologies envisaged in the project and the theme for the mobility was “Water and sustainability” as portrayed in the project logo (Figure 3).

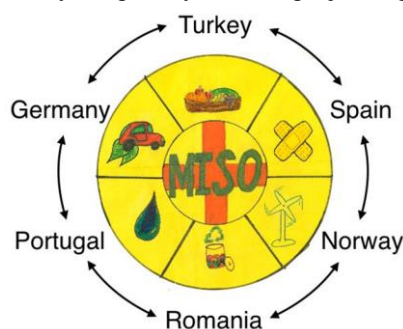

Figure 3. MISO project logo (2018)

Backing up the use of debate in science education “The Guidance report: Improving Secondary Science” (2018), recommends “1b-develop pupils’ thinking through cognitive conflict and *discussion*” knowing that “discussion requires careful structuring”; “2c-promote metacognitive talk and dialogue in the classroom” by argumentation that is one of the more important pillars of debate.

Also, another reason to support debate in Science Education is that it is vital to “developing the competencies for problem solving and innovation, as well as analytical and critical thinking that are necessary to empower citizens to lead personal fulfilling lives socially responsible and professionally-engaged lives” (European Commission, 2015)

E-learning Tools

In relation to the main objective of MISO that affirms that *attracting more students to science* must be accomplished *through new methodology using new ICT applications / e-learning tools*, Lencastre, Bento & Magalhães, 2016 , work states that "The potential of multimedia applications, adapted to the contexts of teaching and learning, can constitute important teaching tools in the dynamics of the classroom."

We should also consider mobile devices in educational environments as a way of transforming pedagogical practices through the training and accompaniment of teachers in the experimentation of innovative pedagogical scenarios such as mobile learning (Bento, M. 2017).

One of the concrete results that MISO project must present is an improvement in the use of ICT. “This is to increase the knowledge of new applications suitable for the development of science and other subjects in a more attractive way. For example: Animoto, Popplet, Powtoon, Kahoot, Tellagami and others are clearly designed to let students work with science in a more attractive way.”

Powtoon (<https://www.powtoon.com>) is a web tool to create an animated presentation which can be used for educational purposes considering the students as the target audience (Moraru et al, 2018). With Powtoon it's possible to build a story scene by scene, create characters and their reactions in different backgrounds, add music or a voice over, and put videos or images up to 5 minutes with the free version. (Moraru et al, 2018). The tutorial videos about debate (Figure 4) that were used for this work were made by SdDESM with Powtoon in Erasmus+ project – Blic&Clic, 2016-2018.

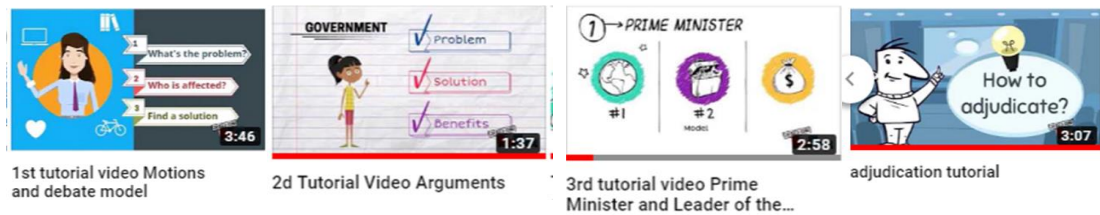

Figure 4. Tutorial videos about WSDC model made with Powtoon

Easyclass (<https://www.easyclass.com>) is an educational free platform of Learning Management System (LMS). Is useful for “non-formal educational activities with students from different schools” and “combines the characteristics of an LMS with those of a social network” (Moraru et al, 2018). The target audience comprises teachers, students, schools or the educational community. The system assigns a unique access code (Figure 5).

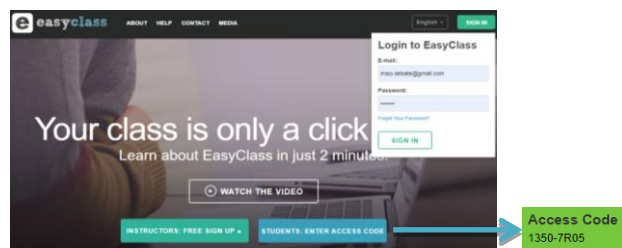

Figure 5. Easyclass layout and access code to the course

The main navigational menu of the course class presents class wall, discussions, assignments, quizzes, gradebook, members and class library for instance (Figure 6).

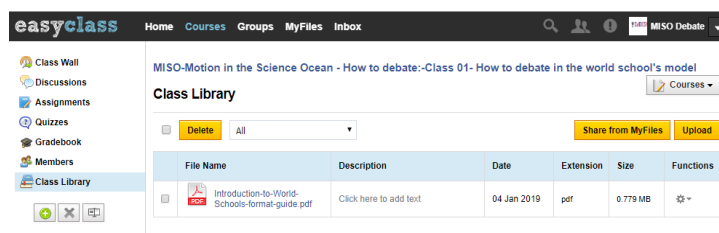

Figure 6. Navigational menu and Class Library

Kahoot (<https://Kahoot.it>), is a free application that provides learning by using games. Enables the creation of quizzes, implementation of games and debates and also helps to understand what the students have learned about a particular issue in real time (Moraru et al, 2018).

Mentimeter (<https://www.mentimeter.com>) is an interactive tool for presentation and collaboration featuring unlimited votes, polls and more to have audience actively participate in during events, classroom, conferences or meetings. A great advantage is that all features are free (Moraru et al, 2018).

WhatsApp is a free messenger application with multiple collaborative features like multimedia messages (pictures, videos, audios as well as simple text messages) or group chat (interaction with 50 members maximum), with no need to remember username or passwords and it is very popular among students. The blended use of this features “made WhatsApp a new and convenient tool for teaching learning activity”, Gon, Sonia & Rawekar, Alka, 2017.

Objectives

The main goal of this work was to train high schoolers from the 6 countries involved in the MISO Erasmus+ Project along with the purpose of making known the competitive debate in the WSDC model. Also, it was intended to contribute to the improvement of the following skills/competences: critical thinking questioning; interpersonal and oral communication; public speaking competence and development of the acquisition of the new digital skills by students and teachers. Assessment of the activities by gathering possible testimonies from the target audience.

Material and Methods

Before the Portuguese mobility

The methodology used comprised the following steps:

Creation of an **Easyclass** online course, “How to Debate” (Figure 7), with:

- Tutorial videos on the WSDC model about “Competitive Debating – World Schools”, “Motions and Debate Model”, “Arguments”, “Prime Minister and Leader of the Opposition” and “Adjudication”, made with **Powtoon** by SdDESM. (Figure 4).
- Quizzes for each tutorial video and a short answer /essay question (Figures 7 and 8).

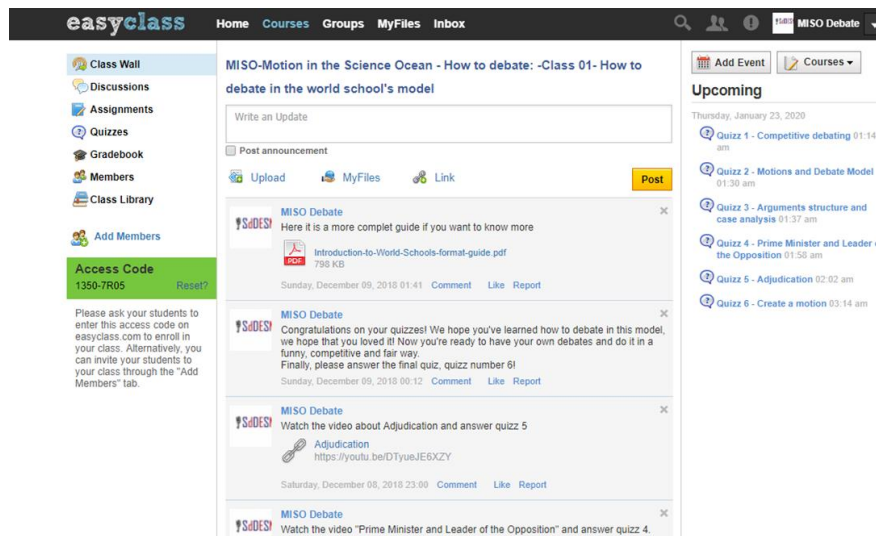

Figure 7. Easyclass course “How to debate in WSDC” layout

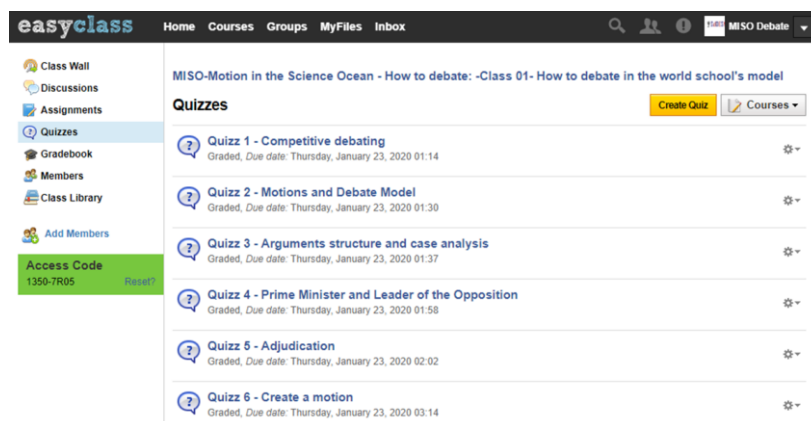

Figure 8. Easyclass course quizzes

Videoconference through Skype, with all the participating countries, for improving communication between students (Figure 9).



Figure 9. Videoconference

Creation of five WhatsApp groups (Figure 10). These groups were named after five oceans, with 10 students each, as planned for the mobility in general, for further communication between students, development and understanding of the debate rules, coordinated by SdDESM students.

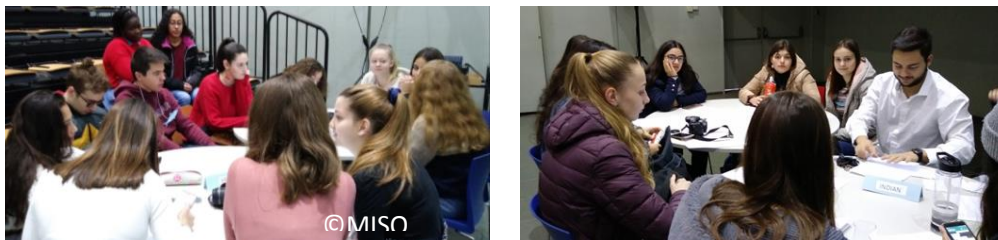

Figure 10. Two of five WhatsApp groups

On the Portuguese mobility

On the first day:

Preparation for motion analysis/discussion with the five working groups, named after the oceans. For this task the method was to distribute the SdDESM students by the five groups to guide/supervise the construction of the Government and Opposition speeches for the given motion (Figure 11). “In order to encourage students to spend adequate time thinking about both sides of the debate question, students should be compelled to prepare to debate both positions (...).” Andrew L. Oros (2007). For this work the given motion was: “*This HOUSE believes that overfishing and pollution can compromise our survival on a long term basis*” accordingly with the mobility theme “Water and Sustainability”.

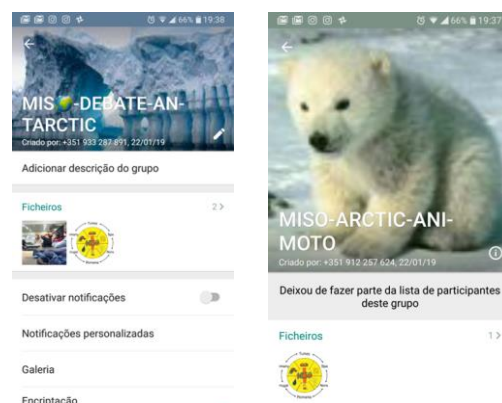

Figure 11. Two of five groups preparing the debate

Constitution of government and opposition teams (Figure 12).

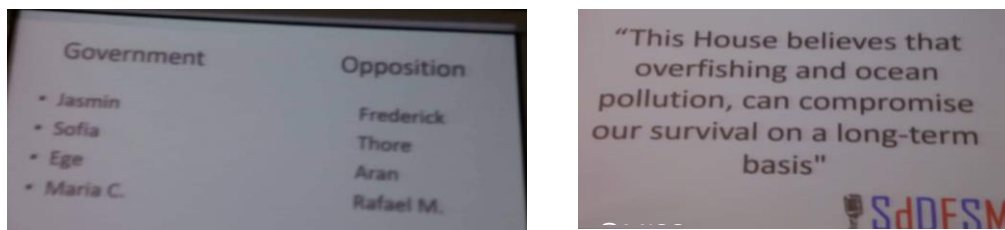

Figure 12. Members of Government and Opposition and Motion

On the debate day (4th day of the mobility – 7th February 2019):

Motivation for the debate and evaluation of the preparation for the debate with a Kahoot quiz (Table 1)

Table 1. Kahoot questions

Scientific questions	Debate questions
1 – Which is the biggest ocean in the world?	3 – Whose is the first speech?
2 – Where are located the Azores Islands?	5 – What is a POI (Point Of Information)?
4 – Which of these oceans has the least amount of oxygen?	6 – Who evaluates the debate?
9 – What oceans bathe in Oceania?	7 – How many people are in each team?
10 – Which ocean has the most amount of fresh water?	8 – Who advocates the motion?
11 – Where is the Point Nemo (the most remote point in the ocean)?	13 – In what speech you can't take questions?
12 – How long does it take the water to travel around the world?	14 - Who are you (public)?
	15 – How many teams participate in the debate?

Final debate at school between multinational team's supervised/supported/commented by SdDESM students.

Use of Mentimeter before and after the debate to understand the popular vote and how this could change with well thought arguments.

Results and Discussion

About Easyclass, not all members of the course answered the questions, perhaps because they were graded which brought a more serious character to the activity that wasn't intentional but the vast majority of the more than 50 students and teachers enrolled to be a member and see the videos. (Figure 13)

Student Name	Quiz 1 - Competitive debating		Quiz 2 - Motions and Debate Model		Quiz 3 - Arguments structure and case analysis	
	Max points	Weight	Max points	Weight	Max points	Weight
Jonathan Kille Aalen	60	16.7%	90	16.7%	40	16.7%
Maria Carvalho						
Jasmin Yagmur Celiker						
olga coelho	60					
Ima constantin						
Cem Doğan						
Ege Doğan						
voicu elisa						
Stancu Eliza						
Stancu Eliza						
Mafalda Ferreira						
Giulia Gheorghe						
Carol Mihai Ghioaidă	30		15			
Ana Gomes						
Anna Hernandez	60		27.5		10	
Average	49.2 / 70		40.0 / 90		24 / 40	
Publish	Published		Published		Published	

Figure 13. Easyclass gradebook

In relation to the fulfillment of the purpose of evaluation through the collection of testimony, it was only possible to obtain the testimony of a Norwegian student (Frederick) who played the role of opposition leader and also of a Portuguese pupil (Rafael), this one in response to an interview with a local newspaper.

WhatsApp groups

Not all the WhatsApp groups were very dynamic but they permitted more closeness between students and the students also used them for other activities of the mobility.

Frederick's Testimony about the Easyclass course and Videoconference

*"The course you sent was great.
The explanations were understandable, and I liked the visual element of the videos.
Many complex definitions that were relevant to the debate were presented well in the course, such as "adjudicator" and "motion", which made it easier for me to understand further explanations using these terms during the video conference.
The speech in the course was loud and clear.
The course aided me immensely, and I felt that I was well prepared to debate in Portugal after I had watched the course."*

Frederick's Testimony about Preparation for Debate and the Motion

*"In Portugal, I prepared for the debate by writing relevant notes and asking Lúcio (Portuguese host and SdDESM member) further questions regarding the debate. He helped me a lot by giving me an idea of what the debate will be like, and by repeating the rules for me.
Concerning the motion of the debate: I loved how the problem of marine pollution was talked about alongside overfishing. Fish is important in both the Norwegian and Portuguese culture, as we are both by the coast, and we both have pollution problems. Therefore, it was clever to set up a debate about overfishing and marine pollution as a single entity."*

Rafael's Testimony

"... many students brought up to the table of discussion interesting facts that I didn't know about, but made all the difference."
This testimony highlights the facilitating nature of the participation and discussion that the debate may have.

Before the debate

Before the debate there was a kahoot quiz as planned that brought some fun and motivation to the debate by remembering some of the important features about WSDC model and information that could be helpful.



Figure 14. Kahoot

After Kahoot we used Mentimeter to make an assessment of the audience position on the motion in question and the result were pro-Government (Figure 15).

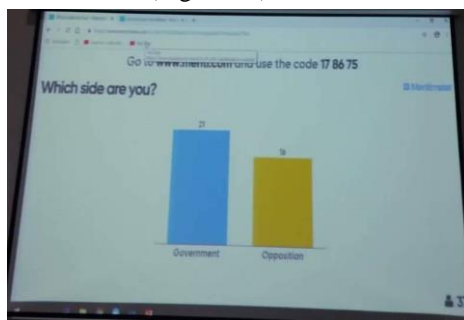

Figure 15. Voting with Mentimeter

At all moments of the Debate an SdDESM student explained to the audience (Figure 16) the several steps of the layout in WSDC model. For the present work there were no time limits and the Chairperson and time keeper role was done by the adjudication team of two Portuguese debaters from SdDESM.



Figure 16. SdDESM student explaining step by the debate



Figure 17. General view of the debate and Opposition team

Frederick's Testimony about the debate

“On the day of the debate, I prepared for the debate by reflecting over the motion with my fellow students, and my fellow teammates. The time we were given to prepare was sufficient.

We, The Norwegian Team, were apprehensive when we found out that we had to debate for 8 minutes, as we thought that 8 minutes sounded like a long time. We were relieved when we were told that we did not have to debate that many minutes at a time, as we were inexperienced in the field of debating.

I was a bit nervous before the debate, but it was manageable, as teachers and students made the debate out to be less important than the debaters initially thought it was going to be. The teachers were also sympathetic to the students' lack of debating experience. Thus, I expected a relaxed debate.”

The mobility activities, previous to the debate, like students presentations about “Impact on the Oceans” (day1), a visit to an aquarium (Sea Life) and to CIIMAR (Interdisciplinary Centre of Marine and Environmental Research of Porto University) to assist a lecture about microplastics (day2) and experiments in the school lab about sea pollution (day4) were very useful to complement information for the arguments that were going to be presented.

Finally, after the debate we did a second vote with Mentimeter and the result was very similar (unfortunately there are no photos) which means that the opposition was not persuasive enough to change the vote. Analyzing this we should consider several points, since if the audience was relatively homogeneous, aware of the environmental problems and their consequences and would therefore be more sensitive to the position of the government by which, taking this aspect in consideration the motion could be unbalanced or had a greater difficulty to defend the position of the opposition.

And to evaluate the opinion of the audience about the debate we also used the Word Cloud feature of Mentimeter by asking “In a word this debate was...” and the result is depicted in Figure 17. We should note that although the opposition didn’t change the audience opinion it was recognized that the leader of this team had a very good performance in terms of analytical and critical thinking – it was Frederick.

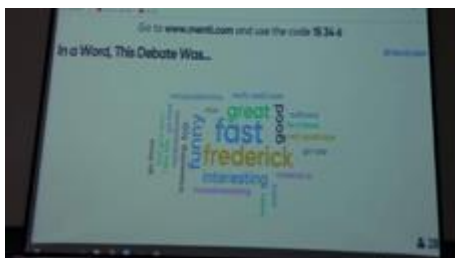

Figure 17. Mentimeter Word Cloud result

Conclusion

The methodology that we followed was important to the success of the debate.

The course was well structured and the videos were simple, concise and attractive on the audiovisual point of view so we can consider that the course could be used again with another group of target audience.

The use of all the other e-learning tools was important and brought some fun and more active participation and they can have an interesting place in the classroom and teachers practices.

We think that is safe to say that the objectives of this work have been met in general and that this activity contributed to the achievement of MISO project specific objectives.

This debate also met one of the project competences which is understanding scientific content and foster structured international cooperation objectives which explains a greater closeness and understanding between the students with very different cultures. So, ultimately this experience provided an inclusive experience and it was platform for the students to speak up and be heard in a safe and structured environment. <https://idebate.org/about-idea-nw>

It seems reasonable to say that a high school debate society such as SdDESM can be a great and useful chance for high school students to train and improve oral / public speaking competences and may be particularly useful in knowing how to build a convincing argument without the constriction of the classroom.

Regarding science education, this activity may improve the ability to understand and argue in a more structured and complete way by provoking metacognitive talk.

Ultimately, in this way, when students have to argue against their natural point of view will be clearer the understanding that the arguments have at least two sides and therefore they can understand the motivation of people who think of different way. In this way, students can become more active and more participatory participants, who are able to see the relationships between the subjects, improving the analytical skills and the skills of speaking in public.

Recommendations

We recommend a more rigorous registration of the results obtained with e-learning tools.

Acknowledgements

This work was “Co-funded by the Erasmus+ Programme of the European Union” - “MISO – Motion in the Science Ocean” - Ref. Number 2018-1-DE03-KA229-047185_6

We would like to thank to Isabel Allen (isabel.allen@aemaia.com) and Manuela Pinho (manuela.pinho@aemaia.com), teachers and Coordinators of MISO portuguese team, and also to the other members of this team (beside authors Luísa Santos and Neusa Fernandes), José Dias, Rui Ribeiro, Ana Paula Ribeiro, Cristina Dias, Fernanda Teles, Maria Jorge Sampaio, Olga Carneiro and Olga Coelho, for the opportunity to develop the work of SdDESM and the excellent organisation of the portuguese mobility and our heartfelt thanks to all of the students and teachers of the participating countries.

We also would like to thank the SdDESM *alumni*, Rita Nanim, mentor and trainer, and Alexandre Gouveia, Ana Carolina Sequeira, Catarina Costa, Beatriz Alves, Diogo Penas, Inês Mendes, Natacha Marques, (authors of the tutorial videos), Diogo Pereira, Francisco Teixeira, Mykola Shelofastov for their work in SdDESM and support given to current SdDESM students.

We also thank Joana Carrilho and Luísa Taveira, members of SdDUP (Debate Society of Porto University <https://www.sdd.up.pt/>) and mentors for the SdDESM students for all the support in training and debating.

References

- About IDEA. (2017, February 07). Retrieved from <https://idebate.org/about-idea-nw>
- Bellon, J. (2000) *A research-based justification for debate across the curriculum. Argumentation and Advocacy*, Winter 2000; 36, 3; Research Library pg. 161
- Bento, M. et al. (2017) Trazer vida à sala de aula: utilização inovadora de dispositivos móveis no processo educativo. Challenges 2017: Aprender nas Nuvens, Learning in the Clouds. *Atas da X Conferência Internacional de Tecnologias de Informação e Comunicação na Educação – Challenges 2017*. Centro de Competência em Tecnologias de Informação e Comunicação na Educação (CCTIC-IEUM). ISBN 978-989-97374-5-7
- EEF (2018) *Improving secondary science: Guidance report*. Retrieved from: https://educationendowmentfoundation.org.uk/public/files/Publications/Science/EEF_improving_secondary_science.pdf
- European Commission (2019) Erasmus+ Programme Guide. Retrieved from: https://ec.europa.eu/programmes/erasmus-plus/resources/documents/erasmus-programme-guide-2019_en
- European Commission (2015) *Report to the European Commission of the Expert Group on Science Education: Science Education for Responsible Citizenship*. Retrieved from: http://ec.europa.eu/research/swafs/pdf/pub_science_education/KI-NA-26-893-EN-N.pdf
- Ferreira da Cunha, A. (2013) *How to Start a Debate Society?* New York, Amsterdam, London: International Debate Education Association. Retrieved from: https://debate.uvm.edu/dcpdf/HT%20Start%20A%20Debate%20Society_final.pdf
- Gon, Sonia & Rawekar, Alka. (2017). Effectivity of E-Learning through Whatsapp as a Teaching Learning Tool. MVP Journal of Medical Sciences. 4. 19. 10.18311/mvpjms/0/v0/i0/8454.
- Lencastre, J. A., Bento, M., & Magalhães, C. (2016). *MOBILE LEARNING: potencial de inovação pedagógica*. In Tânia Maria Hetkowsky & Maria Altina Ramos (orgs.), *Tecnologias e processos inovadores na educação* (pp. 159-176). Curitiba: Editora CRV. ISBN: 978-85-444-1126-1
- Moraru, P., Silva, B., Allen, I., Dias, J., Ribeiro, R., Pinho, M., . . . Bento, M. (2018). *Teaching toolkit: Innovative use of mobile devices in the educational process*. ISBN 978-989-8525-58-1
- Oros, Andrew L. (2007) *Let's Debate: Active Learning Encourages Student Participation and Critical Thinking*, Journal of Political Science Education, 3:3, 293-311, DOI: 10.1080/15512160701558273. Retrieved from <https://www.tandfonline.com/doi/abs/10.1080/15512160701558273?needAccess=true#aHR0cH>

- M6Ly93d3cudGFuZGZvbmxpbmUuY29tL2RvaS9wZGYvMTAuMTA4MC8xNTUxMjE2MDc
wMTU1ODI3Mz9uZWVkbWVjZXNzPXRydWVAQEAw
- Sanchez, C. (2012-2014). *A quick introduction to debating in schools - WSDC format and Club or Classroom implementation*; Debating Society Germany e. V. Max-Born-Gymnasium, Backnang; Retrieved from: <http://www.schoolsdebate.de/pdf/DSGIntroductionToDebating.pdf>
- SdDESM., Santos, L. (2017). *Tutorial video - competitive debating- World Schools* (available in easyclass course – code 1350-7R05)
- SdDESM., Santos, L. (2018, November 01). *1st tutorial video. Motions and debate model*. Retrieved from <https://www.youtube.com/watch?v=o9W3xMUAPyM&t=30s>
- SdDESM., Santos, L.(2018, November 01). *2d Tutorial Video. Arguments*. Retrieved from: <https://www.youtube.com/watch?v=v1CX6S3l6mo&t=16s>
- SdDESM., Santos, L.(2018, November 01). *3rd tutorial video. Prime Minister and Leader of the Opposition*. Retrieved from: https://www.youtube.com/watch?v=ELEcuJ_cQCM&t=13s
- SdDESM., Santos, L.(2018, November 01). *4th tutorial video. Adjudication*. Retrieved from: <https://www.youtube.com/watch?v=5f1uu6JWrcl>

Author Information

Luisa Maria Meira Santos

Agrupamento de Escolas da Maia
Av. Luís de Camões
4470-194 Maia
Teacher- Department of Experimental Sciences and Coordinator of SdDESM / Portugal
Contact E-mail: luisa.santos@aemaia.com

Neusa Fernandes

Agrupamento de Escolas da Maia
Av. Luís de Camões
4470-194 Maia
Teacher –School library and member of SdDESM/ Portugal

Guilherme Alexandre Chaves Jorge

Agrupamento de Escolas da Maia
Av. Luís de Camões
4470-194 Maia/ Portugal

Lucio Magalhaes

Agrupamento de Escolas da Maia
Av. Luís de Camões
4470-194 Maia/ Portugal

Mafalda Brochado

Agrupamento de Escolas da Maia
Av. Luís de Camões
4470-194 Maia/ Portugal

Mariana Goncalves Rebelo

Agrupamento de Escolas da Maia
Av. Luís de Camões
4470-194 Maia/ Portugal

Miguel Ledo

Agrupamento de Escolas da Maia
Av. Luís de Camões
4470-194 Maia/ Portugal

Lara Ferreira

Agrupamento de Escolas da Maia
Av. Luís de Camões
4470-194 Maia/ Portugal

Zenaida Codia

Agrupamento de Escolas da Maia
Av. Luís de Camões
4470-194 Maia/ Portugal

Beatriz Vilas-Boas

Agrupamento de Escolas da Maia
Av. Luís de Camões
4470-194 Maia/ Portugal

An Investigation of Pre-service Middle School Mathematics Teachers' Discussion Skills in the Context of Microteaching Lesson Study

Nadide YILMAZ

Karamanoğlu Mehmetbey University

I. Elif YETKIN-OZDEMIR

Hacettepe University

Abstract: High quality discussions can enable students to understand complex mathematical concepts (Smith & Stein, 2011). Effective mathematics discussions occur when teachers engage the listening, thinking, inquiring, and applying skills of their students (Lobato, Clark & Ellis, 2005; NCTM, 1991). Studies show, however, that teachers face many challenges in orchestrating mathematics discussions (Stein, Engle, Smith & Hughes, 2008). Novice teachers, in particular, struggle to coach their students through the discussion process (Chazen, 2000; Wood & Turner-Vorbeck, 2001). Therefore, the study found that orchestrating mathematics discussions is a skill that pre-service teachers should be encouraged to develop. The aim of this study was to develop pre-service middle school mathematics teachers' mathematical discussion skills in the context of microteaching lesson study. Three senior pre-service teachers participated in and implemented three microteaching lesson study cycles. Data was obtained from lesson plans prepared by pre-service teachers, video recordings, observations, and field notes. Data was examined based on Smith and Stein's (2011) method of orchestrating productive mathematical discussions via anticipating, monitoring, selecting, sequencing, and connecting. Results showed that as microteaching lesson study proceed, pre-service teachers acquired skills about anticipate student thinking and select students' purposeful answers. In addition to that, pre-service teachers began successfully sequencing student thoughts and connecting important points related to big ideas.

Keywords: Discussion skills, Lesson study, Pre-service teachers

Introduction

The existing research emphasizes the importance of social interaction in learning knowledge and skills (Vygotsky, 1978; Lave & Wenger 1991). Learning environments based on social interaction mediate learning because it allows individuals to share their thoughts and see different ideas (Murphy, Wilkinson, Soter, Hennessey & Alexander, 2009; Piaget, 1928; Vygotsky 1978). One of the environments where social interaction is most intense in the learning process is discussion environments (Kelly & Stafford, 1993; Likhulaila Nasution, 2017; Rasmussen, 1984). Discussion environments are distinguished from everyday conversations with their unique features (Chazan & Ball, 1999; Manouchehri & St. John, 2006; Sfard, Neshet, Streefland, Cobb & Mason, 1998). A mathematical discussion environment offers various opportunities for students to share their ideas, to think deeply about the arguments they defend and to evaluate these arguments from different perspectives (NCTM, 2000; 2014; Wood, 1999). It is argued that these discussion environments are one of the criteria required for the realization of effective learning (NCTM, 2000; 2014). Mathematical discussion is not just a conversation; students defend their mathematical ideas and also evaluate different ideas through a filter of reasoning. This whole process provides information about what students learn and how they learn in relation to mathematics (NCTM, 2007; 2014).

Discussion environments provide numerous benefits for both teachers and students. Students deepen their knowledge and exchange ideas with their peers (Stiles, 2016). These discussion environments also allow them to create arguments, test these arguments with their peers and make sense of these arguments (Alwarsh, 2018; Hattie, Fisher & Frey, 2017; NCTM, 2000; National Governors Association Center for Best Practices & Council

- This is an Open Access article distributed under the terms of the Creative Commons Attribution-NonCommercial 4.0 Unported License, permitting all non-commercial use, distribution, and reproduction in any medium, provided the original work is properly cited.

- Selection and peer-review under responsibility of the Organizing Committee of the Conference

of Chief State School Officers [CCSSM], 2010; National Research Council, 2001). This supports their conceptual learning (Cobb, Boufi, McClain & Whitenack, 1997; Hatano, & Inagaki, 1991; Kazemi & Stipek, 2001; Manouchehri, 2007; Manouchehri & St. John, 2006, Michales, O' Connor & Resnick, 2008; Nathan & Knuth, 2003). Teachers gain important insights about the effectiveness of the learning process while working with their students on tasks by observing and interacting with them (Smith & Stein, 2011; Stiles, 2016). In fact, when the curriculum is evaluated, it can be said that emphasis is placed on the importance of discussion environments in the teaching process (MoNE, 2018). These positive contributions of the mathematical discussion environments in the teaching process have attracted the attention of researchers and have given rise to the need of defining which components these environments include (Smith & Stein, 2011). Stein et. al (2008) stated that a successful mathematical discussion environment passes through 5 main processes. It is stated that these processes are anticipating, monitoring, selecting, sequencing and connecting. Anticipating involves the teacher's ability to predict different solutions to a mathematical task. It involves the teacher's anticipating knowledge and skills such as how students will make sense of the task, how they will solve it, which strategies they will use, how they will interpret it and which ideas they will generate. Monitoring involves having a close look at; that is, considering students' mathematical thinking and solution strategies they use while working. One way of doing this is to observe students individually or in small groups. In the advanced steps of the monitoring process, the teacher can formulate the students' strategies before starting the lesson. What is remarkable here is that monitoring is more than watching and hearing. In the meantime, the teacher needs to ask questions to be able to reveal and classify students' thoughts. Selecting involves the teacher's selecting the student's important thoughts. These ideas are a precursor to the objectives intended to be achieved. In the sequencing stage, the purposefully selected student answers are sequenced by the teacher. In the connecting stage, the teacher directs students towards establishing connections between their solutions and establishing meaningful relationships between mathematical ideas. In this process, the teacher helps students to take decisions by providing different approaches to the problem solutions that are dealt with. Effective discussions allow students to solve the problem accurately and effectively. The critical role assumed by the teacher from the preparatory process to the end of the discussion also largely determines the quality of the mathematical discussion because the teacher determines which task is suitable for starting a discussion. This task should include higher order thinking skills, enable a solution with multiple strategies and support conceptual understanding of mathematics (Smith & Stein, 1998; Smith & Piggott, 2007; Jackson, Shahan, Gibbons & Cobb, 2012). The open-ended questions to be asked during the discussion process enhance the discussion as well as revealing students' thoughts (Boaler & Brodie, 2004; Kazemi & Stipek, 2001). In this context, the importance of developing teachers' knowledge and skills about mathematical discussion is once again revealed (Young, 2015). However, research has shown that teachers, especially novice teachers, have difficulty in creating and maintaining mathematical discussion environments (Bennett, 2010; Stein et al., 2008). Thus, various teacher training programs should be designed to support teachers and pre-service teachers' development (Garet, Porter, Desimone, Birman & Yoon, 2001). One of these training programs is the lesson study model (Stigler & Hiebert, 1999). In addition to some of its characteristics such as being cooperation-based and a great emphasis put on practice, the lesson study method also aims at life-long learning and holistic development, which makes it a reform in teacher training (Lee, 2008; Murata, 2010; Robinson & Leikin, 2012). Thus, in the current study, it is aimed to develop the pre-service middle school mathematics teachers' discussion skills through the micro-teaching lesson study.

Method

The current study employed the case study design, one of the qualitative methods. The case study design makes it possible to gather in-depth information about the case of interest and to explore the research questions from every aspect of it (Merriam, 2009). The participants of the current study are three senior students attending a state university in the city of Ankara. These three pre-service teachers participated in three micro-teaching study applications. In figure 1, the teacher training program process is defined. The pre-service teachers prepared the lesson plan in a group; this lesson plan was implemented by one of the pre-service teachers in the group in the university classroom environment. During the implementation, the other pre-service teachers took observation notes. After the completion of the implementation, the lesson was evaluated by the researcher, an expert and the other pre-service teachers.

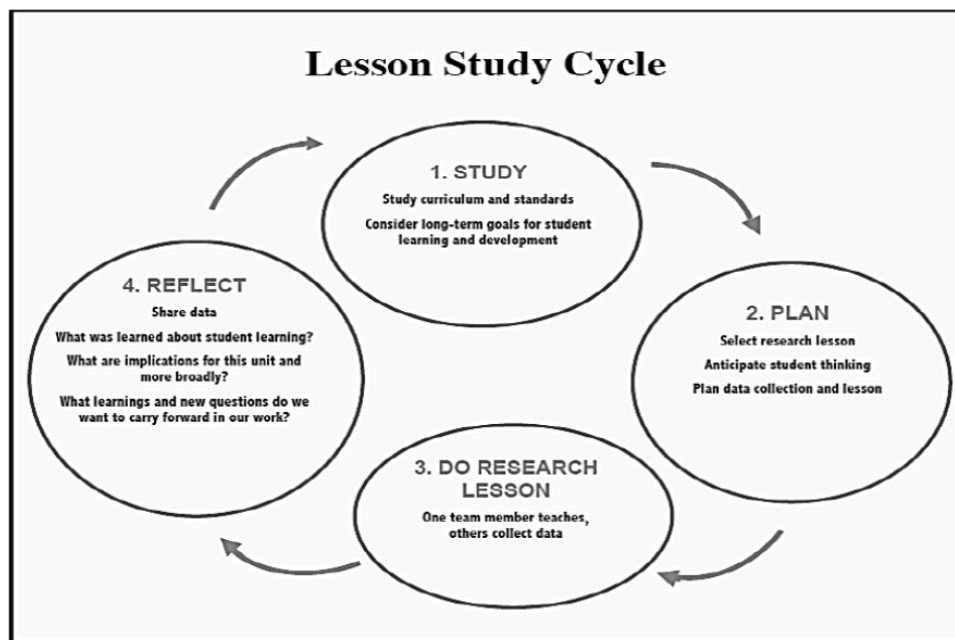

Figure 1. Lesson study cycle adapted from Lewis (2008)

The pre-service teachers conducted activities to address the 7th grade course objectives “Form the pie chart of a data set and then interpret it”, “Form the line chart of the data and then interpret it”, and “Depending on the type of the data collected for the research questions, select a pie chart, frequency table, bar chart or line chart to display the data and then make conversions from one chart type to another chart type”, respectively (MoNE, 2018). As the data collection tools, the lesson plans prepared by the pre-service teachers, video-recordings of the lessons delivered by the pre-service teachers, observations and field notes were used. While analysing the collected data, the descriptive analysis method was employed and the data were analyzed on the basis of the Anticipating, Monitoring, Selecting, Sequencing and Connecting components used by Smith and Stein (2011). The collected data were examined in terms of the number and content of the discussions.

Results and Discussion

In the current study, it was aimed to develop the discussion skills of the pre-service math teachers by means of the micro-teaching lesson study method. To this end, the collected data were analyzed in terms of the number and content of the discussions. When the data were evaluated in terms of the number of the discussions developed by the pre-service teachers, it was found that at first they were inadequate in forming the discussion environment; yet, then in the advanced stages of the process they paid greater attention to forming the discussion environment. The number of the discussion environments created by the pre-service teachers is shown in Table 1.

Table 1. The number of the discussions conducted by the pre-service teachers throughout the micro-teaching lesson study

	1 st Micro lesson study	2 nd Micro lesson study	3 rd Micro lesson study
The number of the discussions	3	4	7

As can be seen in Table 1, the number of the discussion environments created by the pre-service teachers increased in the second and particularly in the third micro lesson studies. When compared to the second and third lesson study cycles, it is clear that the pre-service teachers had difficulty in creating discussion environments in the first lesson study cycle. Moreover, the discussion environments formed by the pre-service teachers were inadequate in terms of including the processes they were expected to have. For instance, it was

observed that the pre-service teacher could not establish a discussion environment in the first micro-teaching lesson study (see the 1st Micro lesson study teaching)

1st Micro lesson study implementation

“ ...

Student: Teacher, why do we draw a pie chart; we have already known the bar chart.

Gameze: Yes, we know the bar chart. A different type of display.”

Here, it is seen that the pre-service teachers could not create a discussion environment and were inadequate in anticipating questions to ask. This prevented the pre-service teacher from establishing a discussion environment. However, in the second lesson study application, it was observed that the pre-service teachers increased their knowledge and skills in anticipating students' answers and thoughts and they reflected this into discussion environments. In addition, they were found to be successful in performing monitoring and selecting stages while they had difficulties in the stages of sequencing and connecting (see the 2nd Micro lesson study teaching)

2nd Micro lesson study implementation

“

Şirin: Why do you think we did these connections (points of change)?

Student: Did we do it to see, teacher? That is, it seems to have decreased like this or to have increased as well

Şirin: Yes, we can see the increase and decrease more easily in this way, can't we? From Monday to Tuesday, for example, it decreased in you [Shows the activity of this group]

Student: It can also be shown in a bar, so why are we drawing it?

Şirin: Yes, then we could talk about it later....”

Here it is seen that the pre-service teacher could start a discussion on a point in which she expected her students to experience difficulties, could address important points by observing the students' works yet couldn't perform the stages of sequencing and connecting. In the last micro-teaching lesson study, the pre-service teachers were observed to be able to create more discussion environments and to include the expected characteristics in these discussions (see the 3rd Micro lesson study teaching)

3rd Micro lesson study implementation

“

Beyza: Ok, can you give me some examples? If someone gives me such an example, wants this, then I use this graph.

Student: Teacher, for example, when it is a temperature change or population change, then I can use the line chart.

Beyza: Hımm. Only temperature or population? What is the important thing, temperature data or change?

Student: Change.

Beyza: Isn't it, a change of something is wanted to be emphasized.

.....

Student: For instance, if we are all given a frequency table showing the numbers of our siblings, then we can show it in a bar chart.

Beyza: Okay. You can show it in a pie chart.

Student: We can show.

Beyza: Which one do you select and depending on what?

When the discussion environment presented here is evaluated, it can be said that the pre-service teacher was able to establish a discussion environment in relation to depending on what the suitable graph was selected. In the discussion environment created, it was observed that the pre-service teachers monitored the works of students, selected the emerging answers and then sequenced them. Then, she was observed to be able to connect the important points in determining the suitable type of graph. A similar situation was observed in another notable discussion environment (see 3rd Micro lesson study teaching).

3rd Micro lesson study implementation

“ ...

Beyza: He/she has received a higher number of votes. What is your comment about the 2nd question?

Student: Teacher, students enjoy the physical education and sports course the most because its line is higher; it is as high as the sum of two courses.

Beyza: Okay, what about the percentage, have you found it? What is its ratio?

Student: 25 percent.

Beyza: What else?

Student: The pie slice of the English course is equal to that of the social studies course.

Beyza: **Then, what does this mean?**

Student: Equal.

Beyza: **Okay, what else will you tell?**

Student: We realized that the least liked course is painting. Its pie slice is very small

Beyza: **In general, do you look at the slice. You are finding the percentages; can you make your comments on the basis of these percentages?**

Student: Yes, the percentage also indicates the slice. As it shows the percentage.

When the discussion environment presented here is evaluated, it is seen that similar to the previous one, the pre-service teacher conducted the discussion on the basis of the students' answers and got the students to think about the important ideas; thus, supported them to establish connections.

Conclusion

It can be argued that the pre-service teachers' participation in the lesson study contributed to the development of their discussion skills. The development of their anticipating skills positively affected the other stages of the discussion process. When the reasons for this development are examined, the specific features of the lesson study approach come to the fore. The pre-service teachers' planning their lessons together and their conducting applications in compliance with their plans provided important insights for the pre-service teachers about what students think, how they will act and what difficulties they will encounter. This allowed them to revise their lesson plans, to implement them again and to reflect what they learned to their classroom environment (Chassels & Melville, 2009; Iksan, Aishah Mohd Nor, Nordiyana Mahmut & Zakaria, 2014; Saito & Sato, 2012). In the literature, similar findings have been reported. Auliah, Anwar and Hardin (2018) conducted a study on the chemistry students at university and found that as a result of the lesson study, the students' communication skills improved. In light of the research findings, it can be suggested that such teacher training programs that can support the development of discussion skills of pre-service teachers should be integrated to undergraduate programs.

References

- Alwarsh, A. A. (2018). Productive Mathematical Discussions in Teaching Through Problem Solving, *Ohio Journal of School Mathematics*, 78, 4-10.
- Auliah, A.; Anwar, M. & Hardin, M. (2018). Enhancing Communication Capabilities in Discussion as an Effort to Improve Learning Outcomes: Implementing Lesson Study in Basic Chemistry Class, *Proceedings of the 1st International Conference on Advanced Multidisciplinary Research (ICAMR 2018)*
- Bennett, C. A. (2010). "It's hard getting kids to talk about math": Helping new teachers improve mathematical discourse. *Action in Teacher Education*, 32(3), 79-89.
- Boaler, J. & Brodie, K. (2004). The importance, nature and impact of teacher questions. In D. E. McDougall, & J. A. Ross (Eds.), *Proceedings of the 26th Conference of the Psychology of Mathematics Education North America*, pp. 773-781. Toronto: OISE/UT.
- Chazan, D., & Ball, D. (1999). Beyond being told not to tell. *For the Learning of Mathematics*, 19(2), 2-10.
- Chazen, D. (2000). Beyond formulas in mathematics and teaching: Dynamics of the high school algebra classroom. New York, NY: Teachers College Press
- Chassels, C. & Melville, W. (2009). Collaborative, Reflective, and Iterative Japanese Lesson Study in an Initial Teacher Education Program: Benefits and Challenges, *Canadian Journal of Education*. 32(4), 734- 763.
- Cobb, P., Boufi, A, McClain, K., & Whitenack, J. (1997). Reflective discourse and collective reflection. *Journal for Research in Mathematics Education*, 28(3), 258-277.
- Garet, M. S., Porter, A. C., Desimone, L., Birman, B. F. & Yoon, K. S. (2001). What makes professional development effective? Results from a national sample of teachers. *American Educational Research Journal*, 38, 915-945.
- Hatano, G., & Inagaki, K. (1991). Sharing cognition through collective comprehension activity. In L.B. Resnick, J. M. Levine, & S. D. Teasley (Eds.), *Perspectives on socially shared cognition* (pp. 331-348). Washington, DC: American Psychological Association.
- Hattie, J., Fisher, D. & Frey, N. (2017). *Visible Learning for Mathematics*. Thousand Oaks, CA: Corwin.
- Iksan, Z. H.; Aishah Mohd Nor, S. N.; Nordiyana Mahmud, S. & Zakaria, E. (2014). Applying the Principle of 'Lesson Study' in Teaching Science Zanaton, *Asian Social Science*, 10(4), 108-113

- Jackson, K. J., Shahan, E. C., Gibbons, L. K., & Cobb, P. A. (2012) Launching complex tasks. *Mathematics Teaching in the Middle School*, 18(1), 24–29.
- Kazemi, E., & Stipek, D. (2001). Promoting conceptual thinking in four upper-elementary mathematics classrooms. *Elementary School Journal*, 102(1), 59–80.
- Kelly, M. & Stafford, K. (1993). Managing Small Group Discussion (Workshop Series, No.9). *City Polytechnic of Hong Kong, Professional development unit* (now City University of Hong Kong, Centre for the Enhancement of learning and teaching)
- Lave, J. & Wenger, E. (1991). *Situated Learning: Legitimate Peripheral Participation*. Cambridge: Cambridge University Press.
- Lee, J. (2008). A Hong Kong case of Lesson study-benefits and concerns. *Teaching and Teacher Education*, 24, 1115-1124.
- Lewis, C. (2008). *Lesson study: A handbook of teacher- led instructional improvement*. Philadelphia: Research for Better Schools, Inc.
- Likhulaila Nasution, M. (2017). *The Implementation of small group discussion to improve students' speaking ability at grade VIII a of mts bina ulama Kisanan*, State Islamic University of North Sumatra, Medan.
- Lobato, J., Clarke, D., & Ellis, A. B. (2005). Initiating and eliciting in teaching: A re-formulation of telling. *Journal for Research in Mathematics Education*, 101–136.
- Manouchehri, A. (2007). Inquiry-discourse mathematics instruction. *Mathematics Teacher*, 101, 290-300
- Manouchehri, A., & St. John, D. (2006). From classroom discussions to group discourse. *The Mathematics Teacher*, 99(8), 544-551.
- Michaels, S., O'Connor, C. & Resnick, L.B. (2008). Deliberative discourse idealized and realized: Accountable talk in the classroom and in civic life. *Studies in Philosophy and Education*, 27(4), 283–97.
- Ministry of National Education (MoNE) (2018). *Matematik Dersi Öğretim Programı (İlkokul ve Ortaokul 1, 2, 3, 4, 5, 6, 7 ve 8. Sınıflar*. Ankara, Türkiye.
- Merriam, S. B. (2009). *Qualitative research: A guide to design and implementation*. San Fransisco: Wiley Publications.
- Murata, A. (2010). Teacher Learning with Lesson study, In P. Peterson, E. Baker & B. McGaw (Ed.), *International Encyclopedia of Education*, 7, (pp. 575-581), Oxford: Elsevier.
- Murphy, K. P., Wilkinson, I. A. G., Soter, A. O., Hennessey, M. N., & Alexander, J. F. (2009). Examining the effects of classroom discussion on students' comprehension of text: A meta-analysis. *Journal of Educational Psychology*, 101(3).
- Nathan, M. J., & Knuth, E. J. (2003). A study of whole classroom mathematical discourse and teacher change. *Cognition and Instruction*, 21(2), 175–207.
- National Council of Teachers of Mathematics. (1991). *Professional standards for teaching mathematics*. Reston, VA: Author.
- National Council of Teachers of Mathematics. (2000). *Principles and Standards for School Mathematics*. Reston, VA: Author.
- National Council of Teachers of Mathematics (2007). *Mathematics Teaching Today: Improving Practice, Improving Student Learning*. Reston, VA: National Council of Teachers of Mathematics.
- National Council of Teachers of Mathematics. (2014). *Principles to Actions Ensuring Mathematical Success for All*. Reston, VA: Author.
- National Governors Association Center for Best Practices & Council of Chief State School Officers. (2010). *Common Core State Standards for Mathematics*. Washington, DC: Authors.
- National Research Council. (2001). *Adding It Up: Helping Children Learn Mathematics*. Washington, DC: National Academy Press.
- Piaget, J. (1928). *Judgment and reasoning in the child*. New York, NY: Harcourt, Brace & World.
- Rasmussen, R. V. (1984). *Practical Discussion Technique for Instructors*. AACE Journal.
- Robinson, N. & Leikin, R. (2012). One Teacher, Two lessons: The lesson study process. *International Journal Science and Mathematics Education*, 10, 139-145.
- Saito, E. & Sato, M. (2012). Lesson study as an instrument for school reform: A case of Japanese practices, *Management in Education*, 26(4), 181–186.
- Sfard, A., Neshet, P., Streefland, L., Cobb, P., & Mason, J. (1998). Learning mathematics through conversation: Is it as good as they say? *For the Learning of Mathematics*, 18(1), 41-51.
- Smith, M. S. & Stein, M. K. (1998). Selecting and creating mathematical tasks: From research to practice. *Mathematics Teaching in the Middle School*, 3(5), 344-350.
- Smith, M. & Stein, M. (2011). *5 Practices for orchestrating productive mathematics discussions*. Reston, VA: The National Council of Teachers of Mathematics, Inc.
- Smith C., & Piggott J. (2007, November). Enriching mathematics: Reflections on building a learning community. *Philosophy of Mathematics Education Journal*, 22.

- Stein, M. K., Engle, R. A., Smith, M. S., & Hughes, E. K. (2008). Orchestrating productive mathematical discussions: Five practices for helping teachers move beyond show and tell. *Mathematical Thinking and Learning, 10*(4), 313-340.
- Stiles, J. (2016). *Supporting mathematical discourse in the early grades*. Education Development Center, Inc.
- Stigler, J. W. & Hiebert, J. (1999). *The teaching gap: Best ideas from the world's teachers for improving education in the classroom*. New York: The Free Press.
- Wood, T. (1999). Creating a context for argument in mathematics class. *Journal for Research in Mathematics Education, 30*(2), 171-191.
- Wood, T., & Turner-Vorbeck, T. (2001). Extending the conception of mathematics teaching. In T. Wood, B. S. Nelson, & J. Warfield (Eds.), *Beyond classical pedagogy: Teaching elementary school mathematics* (pp. 185–208). Mahwah, NJ: Erlbaum.
- Vygotsky, L. S. (1978). *Mind in society: The development of higher psychological processes* Cambridge, MA: Harvard University Press.
- Young, J. S. (2015). *Orchestrating Mathematical Discussions: A Novice Teacher's Implementation of Five Practices to Develop Discourse Orchestration in a Sixth- Grade Classroom*, Master thesis, Brigham Young University, Provo.

Author Information

Nadide Yilmaz

Karamanoğlu Mehmetbey University
Karaman/Turkey
Contact E-mail:nadideylmz70@gmail.com

I. Elif Yetkin-Ozdemir

Hacettepe University
Ankara/Turkey

Learning Through Exploration and Research

Andreja MARZI

Secondary School of Economics and Business Koper

Abstract: Potable water, one of the crucial natural resources, is becoming increasingly affected by pollution, which is putting people's health at risk. As part of the extra-curricular activity Chemistry Club, we tackled the investigation of water resources in the vicinity of our school. Research that is integrated into the learning process should come to resemble real scientific research. Exploration and research provide the student with an opportunity to form knowledge in an active learning process – through research work, while they also help us achieve a major contemporary educational goal, that is the development of natural sciences literacy. Through research assignment we focused on brooks and water wells, where we measured chemical attributes of water. With the help of the colorimetric method we established the concentration of nitrates, nitrites, ammonium ions and phosphates as well as the pH value. We found out that chemical water attributes did not exceed the permitted levels set by regulations for potable water.

Keywords: Chemical water attributes, Research assignment

Introduction

Importance of Water in Slovenia

We are usually reminded of water's significance only after it is gone or when it gets contaminated. Because potable water does not pose a major problem in Slovenia, Slovenians are not conscious of the fact that water is a natural resource whose supplies are most limited. Population growth, climate changes, and, above all, our water management could lead to a great global crisis. Although more than 70% of the world's surface is covered by water, only 2,5% of it is fresh water, and as much as 70% of the latter is in a frozen state. People can thus consume less than 1% of water on our planet.

In Slovenia, most water is used for supplying households and in the industry. Slovenia has lots of available water, but its quality is not satisfactory. Central sources of potable water supply, such as zones of soil water and Karstic springs, are also polluted.

In Slovenia, 70 % of water is used in the energy industry for cooling, 16 % is used as drinking water, and 14 % as process water. In households, drinking water is used for: bathing and body-washing (32 %), sanitation (32 %), laundry (14 %), dishwashing (7 %), cleaning (4 %), cooking (7 %) and other things.

Slovenia has continental climate with great temperature differences between summer and winter, except for the coastal part of the country, where we find Mediterranean climate with mild winters and warm summers. The distribution of precipitation is not even; in eastern Slovenia, most rainfall is in the summer, while in the rest of the country, rainfall is concentrated in autumn, due to the influence of the Mediterranean Sea. As far as the amount of rainfall is concerned, the annual average for the Bohinj area is more than 3000 mm, while it is less than 800 mm for the Prekmurje region; for the coastal region, it is 1000 mm. Particular areas can also be distinguished by various types of torrential rain which differ in terms of duration and amount. In the high mountains and highlands of Alps and in the Dinaric Mountains, the downpours are long and heavy. The rain can also be heavy in the coastal area and in the hills of Brda, while the downpours are short-lived in the eastern part of Slovenia. (see Fig.1)

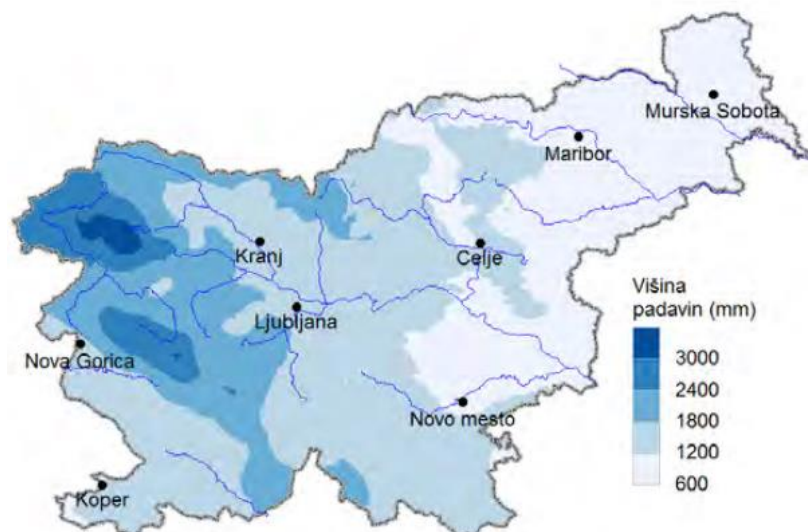

Figure 1. Precipitation in Slovenia in 2017 (source: revija Ujma)

Chemical Parameters

The health adequacy of drinking water is determined by microbiological and chemical parameters. What follows is a list of some chemical parameters set for drinking water in accordance with Rules on drinking water (Official Gazette of the Republic of Slovenia, No 19/04, 35/04, 26/06, 92/06, 25/09, 74/15, 51/17). We have also added the description of the phosphate parameter, which is absent from the above mentioned Rules.

pH value indicates the acidity or alkalinity of water. Very low or very high pH values in drinking water may be a result of accidents, mistakes in water treatment or release from materials in contact with water (e.g. cement pipes). Water with extremely low or high pH values causes irritation to the eyes, mucous membranes and skin as well as tissue damage, and the pH value indirectly affects the materials in contact with water.

Nitrates and nitrites are sources of nitrogen in the environment. They are well soluble in water. We are exposed to nitrates and nitrites through food and water. Nitrates and nitrites are harmful to human health, as they disrupt the oxygen flow around the body. In Rules on drinking water, the limit value for nitrate is 50 mg/L, and for nitrite, it is 0,50 mg/L.

Phosphates are not usually found in the natural environment. In watercourses running through agricultural areas, the values rise to 0,25 mg/l and more. Excessive quantities of phosphates cause mass spread and growth of plants, especially green algae and cyanobacteria. Phosphates are nutrients for plant growth, but greater concentrations signal water pollution. Concentrations of 1000 - 1200 mg/l may produce laxative effects. Rules on drinking water do not set any limit values.

Methods

Experimental work

This article presents an example of writing a research paper undertaken by students aged between 14 and 15 years. Before we set to writing the research paper, we took a look at the school's surrounding area and made enquiries about any streams or wells in the vicinity of our homes. After locating several streams in close and far proximity to the school, we began planning our research.

Our essential research method was laboratory work. We decided that we would do chemical analyses at school, in the framework of Chemistry Club, since all the required laboratory equipment and reagents were at our disposal. As part of laboratory analyses, we conducted chemical analyses, by which we determined the concentration of nitrates (NO_3^-), nitrites (NO_2^-), phosphates (PO_4^{3-}) as well as pH value.

In the experimental part we set three hypotheses. First hypothesis: Nitrates and nitrites do not exceed limit values. Second hypothesis: pH values are between 6,5 - 9,5. Third hypothesis: The values of chemical parameters are lower in wells than in streams.

Sampling points

Sampling points are presented on the map below. (see fig. 2)



Figure 2. Sampling points

We decided to analyse water in eight streams (sample number: 1, 2, 3, 4, 6, 7, 8 and 11) and three wells (sample number: 5, 9 and 10), where we did the sampling of water and took field measurements.

Laboratory equipment

For our experiments we needed the reagent case for water analysis Machery Nagel visicolor ECO Analysenkoffer and thermometer for measuring the temperature of water at sampling points.

The work procedure

Analyses were based on the colorimetric method, set out on the enclosed leaflet with a colour-comparing scale and manufacturer's instructions. The intensity of the sample's colour is compared to a ready-made colour scale with the help of which we read off ion concentration in the sample.

For example, here is the procedure for determining phosphates.

First, we washed the two containers with samples. We then filled them with sample water to the 5 mL mark. One container was left for comparison. We added 6 drops of reagent PO₄-1 into the second container, stoppered the container, and shook it well. Then we added six drops of reagent PO₄-2, stoppered the container, shook it well and left it to stand for 10 minutes. After ten minutes, both containers were put on the colour scale. At this point, we compared them and read off the concentration of ions. Depending on the concentration of phosphates, the water showed a more or less intense blue colouring.

Results and discussion

Nitrates in water

The results of nitrate analysis in water samples are shown in the following diagram:

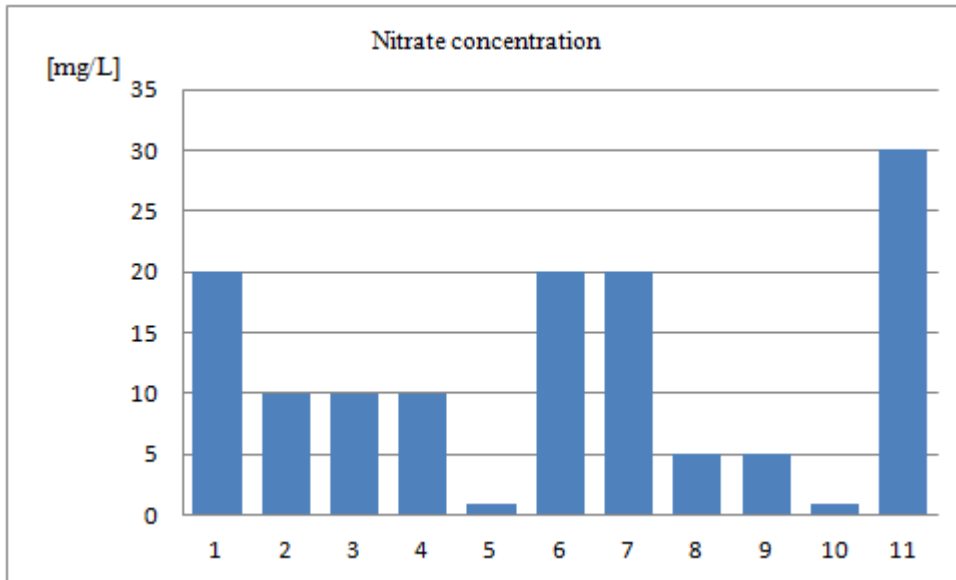

Figure 3. Nitrate concentration in water samples

According to Rules on drinking water, the limit value for nitrate is 50 mg/L. We found that least nitrates were present in sample 5 and sample 10 the concentration was 1 mg/L. The highest concentration was determined in sample 11. (see fig. 3)

Nitrites in water

The nitrite concentration in individual water samples are shown in the table below:

The water sample number	The concentration of nitrites NO_2^- [mg/L]
1	0,05
2	0,02
3	0
4	0
5	0
6	0,03
7	0
8	0
9	0
10	0,02
11	0,05

In Rules on drinking water, the limit value determined for nitrite is 0,50 mg/L. The results of analyses show very low nitrite concentrations in all samples and they did not exceed 0,05 mg/L.

Phosphates in Water

The results of phosphate analysis in water samples are presented in the following diagram:

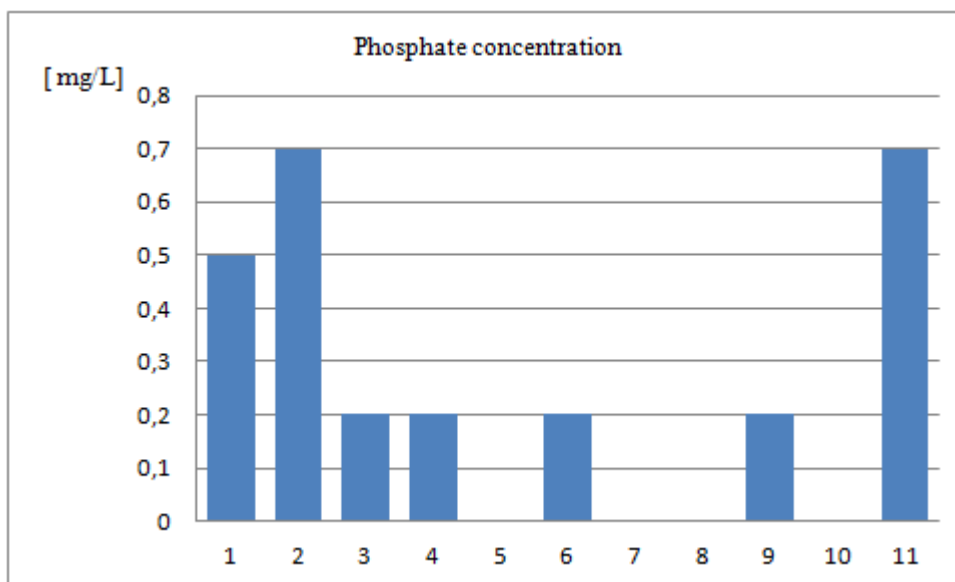

Figure 4. Phosphate concentration in water samples

The results of the analyses indicate that four of the samples (samples number 5, 7, 8 and 10) did not contain phosphates at all, while in other samples the concentrations ranged from 0,2 to 0,7 mg/L. Rules on drinking water do not prescribe a limit value for phosphates. (see fig.4)

pH value

The results of pH value analyses in water samples are presented in the table below.

The water sample number	pH value
1	8
2	8
3	7
4	7
5	8
6	8
7	7
8	8
9	8
10	8
11	8

To sum up the findings, the majority of samples had a pH value of 8, while three samples had a pH value of 7. (Table 2) For pH values, Rules on drinking water set the limit value between 6,5 and 9,5.

Conclusion

The results of experiments showed us that the concentration of nitrates and nitrites does not exceed their limit values in any of the analysed water samples, which confirms the first hypothesis (*Nitrates and nitrites do not exceed limit values*). The pH values of analysed samples ranged from 7, 0 to 8, 0, which supports the second hypothesis (*pH values vary between 6,5 and 9,5*). In the samples from three wells, sample 9 was used to determine the presence of nitrates and phosphates, sample 10 for establishing the presence of nitrites while in sample 5 the presence of nitrates, nitrites and phosphates was not detected. In all samples, the values were very

low. The third hypothesis (*The values of chemical parameters are lower in wells than in streams*) was thus partially confirmed. In some water samples from streams, particular concentrations of the same parameters were the same or occasionally even lower than in water from wells.

The pollution of potable water is caused above all by farming, decrepit and uncontrolled sewerage systems and the failure of proper waste disposal, which contaminate potable water.

This report presents an example of research activity which at all levels of education has recently become very relevant and pertinent. Such literacy should enable today's students and future citizens to actively participate in the emergent technological society. In order to become ready for this task, students have to recognize the practical usefulness of their knowledge in everyday life, acquaint themselves with the procedures and methods of scientific research as well as respect nature and learn about the capabilities and limitations of current science.

References

- Cegnar, T., (2018). Climatic conditions in Slovenia in 2017. *Revija Ujma* (št. 32). Ljubljana. Uprava RS za zaščito in reševanje Ministrstva za obrambo. Available from <http://www.sos112.si/slo/page.php?src=sv61.htm>
- Čuk, P., Lušin, P. (2016). Analize vode (online). Ljubljana: Gimnazija Vič. Retrieved from <http://projekti.gimvic.org/2010/2a/Voda/website/fofati.html>
- Firbas, P. (2004). Kako zdrava je voda: Priročnik za biološki monitoring vode. Ljubljana: Ara Založba.
- Pravilnik o pitni vodi. Uradni list RS, št. 19/04, 35/04, 26/06, 92/06, 25/09, 74/15, 51/17. Available from <http://pisrs.si/Pis.web/pregledPredpisa?id=PRAV3713>
- Rejic, M. (1988). Sladkovodni ekosistemi in varstvo voda. Smolej I. Gozdna hidrologija. Ljubljana: Biotehniška fakulteta, VTOZD za gozdarstvo.
- Smrdu, A. et al. Kemija: i-učbenik v 1. letniku gimnazij (online). Available from <http://eucbeniki.sio.si/kemija1/588/index2.html>.
- Uredba o mejnih vrednostih vnosa nevarnih snovi in gnojil v tla. *Uradni list RS*, št. 84/05, 62/08, 62/08, 113/09, 99/13 in 19/17
- Vovk Korže A., Bricelj M. (2004). Vodni svet Slovenije: Priročnik za interdisciplinarno proučevanje voda (online). Ljubljana: Zveza geografskih društev Slovenije; Maribor: Pedagoška fakulteta. Available from http://www.mop.gov.si/fileadmin/mop.gov.si/pageuploads/publikacije/vodni_svet.pdf
- Zgibanka: Voda mene briga (online). Društvo za razvoj podeželja LAZ, Zg. Jablanica 1, Šmartno pri Litiji. Available from <http://www.jablaniskadolina.si/files/userfiles/file/vodamenebriga/aktivnosti/voda-mene-briga-brosura-web-A5.pdf>

Author Information

Andreja Marzi

Secondary School of Economics and Business Koper
Martinčev trg 3, 6000 Koper
Republic of Slovenia
Contact E-mail: andreja.marzi@gmail.com

Marketing of Library and Information Services in University Libraries: A Case Study of University of Malaya Central Library, Kuala Lumpur, Malaysia

Siti Juryiah MOHD KHALID
University of Malaya

Abstract: Marketing and promotion play a very vital role in creating awareness for library and information products and services. This topic discusses the importance of marketing and promotion in academic libraries with particular reference to Central Library, University of Malaya, Kuala Lumpur. University libraries are established to provide information resources and services in order to support the purpose of the university. There are two research questions of the study. What are the types of information resources that are available in the Central Library? and the other one is what are the marketing strategies used by the Central Library. The objectives of the study are to identify the available information resources and services in the Central Library and to unveil the strategies used by Central Library in marketing its resources and services. The reports included marketing strategies employed by Central Library in promoting and attracting more library clientele as well as keeping them for long in the library. The paper concludes by advising librarians to promote their libraries through exhibitions and displays, publicity and public relations.

Keywords: Marketing, Education, Promotion, University libraries, Information services, Library services

Introduction

Libraries are the knowledge and information foundation of any nation. A library collects, organizes and makes information resources accessible to all kinds of users regardless of their ages, background and interests. Islam (2004) defined library as a learned institution equipped with treasures of knowledge, maintained organized and managed by trained personnel to educate the children, men and women continuously and assist in their self improvement through an effective and prompt dissemination of information.

Libraries and information centers of all types and sizes are faced with the need to market. Librarians and information professionals must learn to effectively market and advertise their services. Same as University of Malaya Library, who are very concerned about customer satisfaction with the services and facilities offered by the library. Marketing is essential to ensure customers aware about the services and facilities offered by the library.

According to Odine (2011) the effectiveness and efficiency of services provided by an academic library are mainly determined by library users. Aina (2004) recognizes this fact when he stated that the user is very critical in the practice of librarianship. No library can exist without the patrons. The entire human and material resources in a library are put in place at considerable expense for the overall purpose of providing effective services to the library users. On its part the library has a responsibility to ensure that its resources and services are used (Edoka, 2000). The user is regarded as the most logical source to determine whether the library is playing its role satisfactorily or not. The mission statement of any academic library should be the provision of excellent service to its users. In higher institution libraries there are various categories of library patrons. They are undergraduates, postgraduates, lecturers, researchers, external users from all walks of life and many professions.

University of Malaya Library is a complex system comprising the following:

Central Library

Branch libraries

- Za'ba Memorial Library
- Tan Sri Professor Ahmad Ibrahim Law Library
- T.J. Danaraj Medical Library

Both the Law and Medical Libraries serve the respective faculties. The Za'ba Memorial Library focuses on the preservation and conservation of Malaysiana items.

The rest of the faculties are served by a network of special and satellite libraries

- Built Environment
- Engineering
- Education
- The Centre for Foundation Studies in Science
- Islamic Studies
- Islamic Studies @ Nilam Puri
- Malay Studies
- East Asian Studies
- Indian Studies
- Language & Linguistics
- Dentistry
- Medical @ Klang
- Museum of Asian Art
- UM Art Gallery

Central Library

Established in 1959, the Central Library located in the middle of the University Campus. It is a four storey building with a floor space of 17,372 square meters. The University of Malaya Library encompasses a network of libraries and through this network the Library is able to provide comprehensive services and facilities using the discipline-based approach. The provision of facilities and services to the campus community is clearly stated in the three Library Quality Management Procedures, namely UM-PT08-PK01: Library Collection; Development; UM-PT08-PK02 : Library Client Services and UM-PT08-PK03 : Management of Education & Training. Through the Library's home page at <https://umlib.um.edu.my>, one is able to explore the multitude of services as well as the various facilities available to the users. The collection within the Library has been developed in line with the teaching, learning and research needs of the University. The Library now holds over 2.1 million items in various formats. In addition to that the Library provides access to more than 44 online databases comprising of more than 46,000 e-journal titles and more than 150,000 e-book titles. UM Library has over 184,884 registered users which can be sub-divided into four categories: academics and non-academic staff, post-graduate students, undergraduate students, research scholars, and other users from different universities/institutions who also use the library's collections.

The UM Library has fifty (54) professional staff and over one hundred fifty (150) support staff (comprising of clerical, administrative and para-professionals) deployed all over the branches. UM Library provides access to both print and electronic informational and instructional resources to strengthen the University's performance of its teaching, learning research, and community by:

- Transforming the University of Malaya Library into a world ranked library, consistent with UM's aspiration for world ranking.
- Supporting of the University of Malaya's global mission, the Library provides professional expertise, diverse information resources, and knowledge-based services for the advancement of its quality research, teaching and learning.

Statement of the Problem

The existence of libraries is being challenged. This is because access to information is now very fast and relies on technology. Users now prefer to turn to the internet to source for information than coming to the libraries. Kaur (2007) reported that library resources are so expensive, but often remain underutilized resulting in wastage of money, time, energy and space. Also, said that “University libraries invest huge amount of money on collection development, processing and storage of information resources” and to ensure maximum utilization of these resources, there is the need for librarians to embark on publicity or sensitization of clientele so as to promote the use of their services. Carrington (2005) also observed that one of the problems or deficiencies faced by library is that of improper dissemination of library services to the target audience and that is one of the reasons for the low usage of library materials and facilities. In view of the above, it is observed that in recent time, UM Library is experiencing loan service declining. It is worrying as the library spent a substantial amount of budget in purchasing and acquiring library materials annually (Zanaria, 2019).

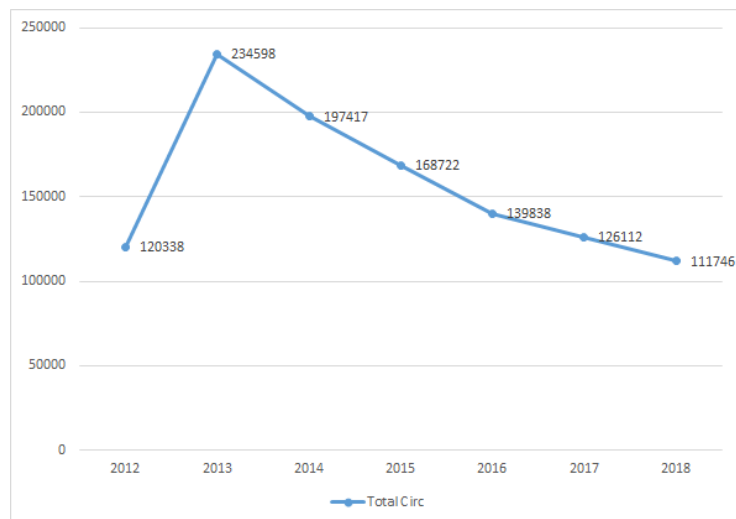

Figure 1. Analysis of borrowing trend (2012 - 2018) from directors station

Research Questions

What are the types of information resources that are available in Central Library?
What are the marketing strategies used by Central Library

Objectives of the Study

To identify the available information resources and services in Central Library
To unveil the strategies used by Central Library in marketing its resources and services.

Significance of the Research

The findings will be significant to academic institutions administration in the area of policy formulation by providing a road map on the information resources and services to be provided to users in order to satisfy their information needs. It is hoped that that it will create awareness to the library committee as regards the strategies to enhance effective marketing of library services to users. Thus the study provides a comprehensive background and current scenario of marketing strategies used in University of Malaya Library.

Library and information services in Central Library

University libraries are established to provide information resources and services in order to support the purpose of the university. Information services encompass services through which librarians directly supply users with information but also interfaces created by librarians through which users could independently find needed information. Generally speaking library user services can be divided into two categories: library public user services and library technical user services. Library public user services refer to circulation, bibliographic

instructions, distance learning, government documentation, reference and special collection. Library information user services focuses on procedures and operations of maintaining, developing and supporting library collection and services behind the scene such as acquisition, cataloguing, classification, inter library loan, document delivery and serial systems. Katz (1999) defined library services as help or assistance given to users in their quest for information resources. Various forms of publicity should encourage people to use the library. This includes welcome address delivered by librarians to users - staff and students of the founding body especially during the orientation programme of the fresh students, exhibition and display of books and sharing of circulars of Library news bulletin. Central Library is divided into different divisions but none, some of these divisions are directly involved in the marketing and promotion of library products and services. Examples are the Client Services, Academic Services, Cataloguing, Information Skills, Acquisition and Information System.

Client Services Division

This division is responsible in providing effective services in meeting the needs of users, fulfill users satisfaction and also providing current information to users. The services provided to users are library material's transaction (loan, return, renew, reserve), Interlibrary Loan and Document Delivery, Library user's Registration (internal user, external user), Reference Desk Services and Services for locating unbound library materials.

Cataloguing Division

This division is responsible to provide access to scholarly materials in the UM Library collection to support research, teaching and learning in the UM community by organizing, describing, and providing effective, accurate tools that assist our clients in locating information resources of value to them. The division is also responsible for the development and maintenance of the UM Library Catalog (Pendeta Discovery) and for the development and implementation of policies and standards that govern the creation and maintenance of the metadata that describe the collection.

Information Systems Division

The division is responsible in ensuring that computer system in the Library Network is fully operational besides providing quality ICT service.

Information Skills Division

The division offers information skills and user education programmes for undergraduates, postgraduates and Academic Staff. The programmes include: i) GIG1007 Information Skills Course. A compulsory course for all undergraduates. Students are taught skills which will be of use for their learning and research. ii) Information Skills sessions for postgraduates. These 2 hour sessions are held at least twice weekly. iii) Consultancy sessions for PhD. Students and Academic Staff. In this individual consultancy sessions, researchers will be guided to the information sources in the library pertaining to their specific area of research.

Acquisitions Division

The Division is responsible for the acquisition of library materials in the form of books, serials (printed and electronic), non-book materials (audio/video tapes, microforms, CD-ROM etc.) and newspapers (local and international).

Academic Services Division

The main functions of the unit are to prepare statistics and reports of University Malaya's publications indexed in Web of Science & Scopus; provide user education (such as workshop and talks) and consultation on publishing in journals indexed in Web of Science & Scopus and related issues; and coordinate and prepare statistical reports of Library services and collections.

Types of library resources in Central Library

The library collection comprises mainly of books, journals, conference proceedings, microform, AV materials, theses and dissertations. UML subscribes to electronic resources such as e-journals, e-books, citation indexes, and bibliographic management software.

(a) Print Resources: These resources are books, journals, newspapers, magazines and pamphlets, bound copies of journals, documents generated within the university (local Contents), manuscripts, conference proceedings, statutes, reporters, government publications,

(b) Non-Print Resources: Otherwise known as electronic resources or audio-visual materials. These are soft copies of information that can only be viewed through the use of compatible hardware or application of information and communication technology. Electronic resources can be found in slides, CD-Roms, microforms, audio cassette, video cassette, long play (LP), Kindle and other storage devices. These resources are called e-books, e-journals, microfilms, microfiches, institutional repositories etc.

Table 1. Library Collection Statistics until 31 December 2018

Collections	Quantity
Printed (books, journals, theses, annual reports, etc.)	1,493,712
Manuscript	409
Non-Printed (photos, films, microforms, etc.)	485,901
Digital (e-books, cd, dvd, e-journals, etc.)	204,981
TOTAL	2,185,003

Table 4. Institutional repositories until 31 December 2018

Repository	Functions	Digital Object
UM Research Repository	An Open Access digital archive containing the details of published and unpublished research work produced by the UM researchers and academic staff.	15,252
UM Students' Repository	An online archive for the written work of University of Malaya students such as academic exercises, dissertations and theses	7,856
UM Common Repository	An initiative by the library to preserve printed items digitally to increase accessibility, visibility as well as conserve old copies of items such as gazettes, magazines, journals and books	7,997
UM Memory	An initiative by the library to preserve University of Malaya valuable photos with historical context for the campus community and nation at large	9,474
UM in the News	News coverage relating to University of Malaya, its staff, students and alumni that have appeared in the local, regional and national newspapers. It also provides newspaper reports and pictorial coverage of events, announcements and achievements of the University. The news are updated regularly by the library staff as featured in the public media. To make the news more accesible and organised to users, each newspaper cutting is accompanied by several subjects.	24,080
Malaysian Arts	Malaysian Art, on the other hand, are news relating to events, exhibitions, artists, developments in the arts arena as reported in the local newspapers.	3,828
		68,487

Literature Review

Significant research on marketing has been carried out around the world to encourage librarians to improve on marketing their products and services.

Library service marketing

Marketing aims to identify the client base, and to determine and fill its needs, wants, and demands by designing and delivering appropriate products and services. The main focus of the concept is the client, and the goal is client satisfaction. According to Madhusudhan (2008), information marketing by university libraries is essential in order to promote the use of information resources; to create perception of need and thereby create demand; to ensure the optimum use of information; to improve the image and status of the libraries and library professionals; to tackle the problems of rising costs of reading materials, journals, and databases; to cope with the information explosion; to introduce cutting-edge information technology systems in library services; to balance shrinking funds; to save libraries from devaluation; to save libraries from declining reader-support and to uphold the dictum that information is power.

The concept of marketing goes beyond the buying and selling of products or services for financial gain, but also to help the parent bodies or organizations in achieving their goals. Marketing in librarianship is an act of planning, organizing, dissemination and controlling of information services on a proactive and users' oriented way that ensures the patrons satisfaction while achieving the objectives of the parent organization (Arachige, 2005).

Marketing in librarianship is an act of planning, organizing, dissemination and controlling of information services on a proactive and users oriented way that ensures the patrons satisfaction while achieving the objectives of the parent organization (Abiola, 2016). To achieve maximum utilization of library resources, librarians must improve the way they market their services due to the fact that marketing is vital to the growth and development of any library irrespective of the parent organization.

The library has many products and services that it can market. Each library needs to identify what it wishes to market and how. Marketing is not just about developing and promoting new services and products but also about bringing awareness to clients of existing services and products and determining their appropriateness. There are seven principles of marketing; these principles are also applicable to Library and Information services. These principles are Product, Price, Place, Promotion, Participants, Physical evidence and Process. These principles are described in brief:

- Product
- Products in Librarianship refer to services or general reference and information services offered by the library. Products are the information, reference, and supplementary services that add value to the traditional library services such as personal assistance, referral services, on-line data base searches, document delivery and interlibrary loan..
- Price
Price can be expressed in currency; in the library, price can be used to express the value of information services: such as Online database usage or a fee of a service or membership. Central Library charges MYR100-200 as library membership fee for all fresh students of University of Malaya. A reasonable amount of income comes from fines charged on overdue books, fees charged on space allocation, printing and scanning services.
- Place
Place of service, based upon knowledge of the market of library, is essential in order to identify users and their discrete information needs and wants. To expand the service area, the library may have branches, bookmobiles, or electronic access, etc.
- Promotion
Promotion includes utilizing persuasive information about general information services, and communicating this information to target market segments that are potential users. Five kinds of promotion include: publicity, public relations, personal representatives, advertising, and sales promotion.
- Participants

The success of any programmes is depend on the feedback of the participants hence participants involved in promoting and marketing of the library services provided by library professionals, their feedback will help to improve the services and library system

- Physical Evidence

The environment in which the reference and information services are delivered that facilitates the performance and communication of the service.

- Process

The procedures, mechanisms and flow of activities by which the reference and information services are acquired

Display and Exhibitions

Exhibition is defined as a public display of books, artefacts, objects, and other materials. Exhibitions can be online, physical or a combination of the two and of any scale or duration, within the literature it is obvious that library exhibitions fall into two major types: physical and online. The exhibition construct has been chosen over display, as exhibition is more encompassing; the word is inclusive of both large scale exhibitions as well as small displays (Williams, 2011). Williams (2011) citing Schaeffer (1991) posited that exhibitions are adjudged to be a major promotional instrument within a library's marketing strategy, as exhibitions are one of the most visual means of showcasing what the library can offer. Exhibition is a precious marketing tool, a poor exhibition can cause dent to the reputation of the library (Cleeve, 1995).

Strategies for marketing and promotional approaches by Central Library, University of Malaya

Central Library introduced some products and services in order to maintain good relationships with its numerous clientele. Among these efforts are the introduction of exhibition and display; complaints/suggestion boxes, information skill session for postgraduate, library information skill course for undergraduate, electronic bill board, audio-visual services, online dissemination of information via the internet technology by creating links for current information on the library portal. Eye-catching displays, interactive web sites, contests, library briefing for new students during new semester opening and trial classes for introduction of new databases. Knowledgeable and enthusiastic staff members are also great promotion tools used to persuade the library users. The marketing strategies used by Central Library are discussed below:

Publicity

Wider publicity is given to the Library products and services by various ways. For example, banners, Library website and library portal are used for dissemination of information related to the various programmes and activities being performed by the library including the specific ventures such as conducting of the workshops/seminars/classes/training sessions.

Users Education

Users' education is a compulsory two credit hours course taught (GIG 1004) in University of Malaya Library. It is compulsory for undergraduate students of the institution particularly the newly admitted students. The course is one of the strategies used by the Library to bring students closer to the library. The aim of user education in University of Malaya is to enable the students use the library effectively with minimum problems for the purpose of learning, research and recreation.

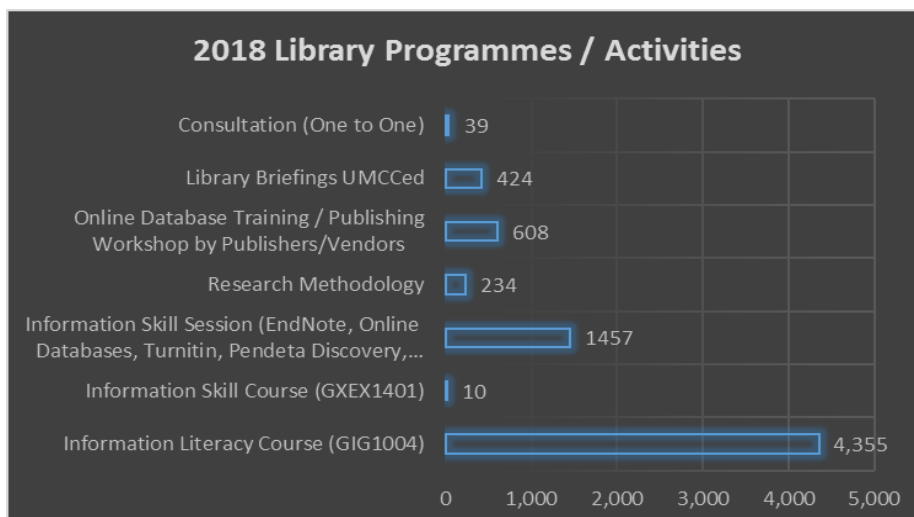

Figure 2. 2018 Library Programmes and activities

Digital Reference Service

Digital reference services can be made through e-mail or chat. Libraries are also using a couple of different means of running an e-mail reference service: using basic e-mail or web forms. Live Chat is a very popular means of communication over the internet. Chat Reference enables the user and the addressees librarian to exchange brief written messages in quick succession. The communicating parties are online at the same time and can therefore react. Since 2018, live chat at UM library has started and without coming to the library, users can communicate with librarians during office hour from Monday to Friday only.

Internet and Social Networking

To keep pace with evolving information technologies, UM librarians use a group of software applications including blog and social networking services such as Twitter and Facebook to market the services and resources with mixed success. Our librarians use tools such as RSS (Really Simple Syndication), tagging and bookmarking as a means of promotion. Besides posting materials for promotion purposes, UM librarians also post photos of the organization and staff to provide a virtual tour of the library.

Twitter is being used in libraries to market their services and resources by actually using the social networking site to provide the service (Fields, 2010; Milstein, 2009; Rodzvilla, 2010; Stuart 2010). A favorite networking site for people of all ages to keep in touch is Facebook. A broad study by Hendrix, Chiarella, Hasman, Murphy and Zafron (2009) on the use of Facebook by more than seventy librarians found that most libraries used the social networking site to predominantly market their services. A study by Garcia-Milian, Norton and Tennant (2012) suggests that the more likes a library's Facebook page has, the greater the potential for engagement with users through this medium.

Display and Exhibitions

Davidson (2001) stressed the importance of marketing library and information services through displays and exhibitions. According to him exhibition can boost current awareness in the library because it allows library clientele to know the existence of materials in the library. Each year, UM library organized 2-3 exhibitions specifically to promote library collections by displaying the items for public according to the theme chosen. This effort is organized by a group of librarians appointed as UM Library Exhibitions committee.

Face-to-face events or “Library Clients Day”

Library Clients Day is an annual event dedicated to professional development, networking, and continuing education within the University. Thinking of the importance of this marketing activity, Client Services Division, Central Library has organized the Clients Day each year since 2014 in conjunction with the start of the new

semester and the ongoing efforts to promote library services to students and staff of UM. Among the activities organized are e-resources Clinic to provide guidance and information related to Endnote, Online Databases, Turnitin and Online Public Access Catalog. Institutional Repositories Clinic to explain more closely to repositories which relevant to University of Malaya, special discounts up to 20% of overdue fines to encourage users to pay the fines, e-services Clinic to explain the services available in the Library Interactive Portal especially for Document Delivery service and Inter-library loan, demos to promote the latest database subscribed by library. Readers Voluntary Registration segment in collaboration with the Counseling, Career and Disability Section UM to inform users about the existence of those services to assist students with disabilities (PWDs) in the library and encourage people to sign up to become a volunteer reader for this group and introduction of Mobile application Clinic to promote new services offered to users as part of its initiative to promote ebooks as well as motivate and encourage the culture of reading among its community.

Conclusion

Academic librarians are facing a variety of challenges and obstacles such as 'juggling many responsibilities at once', 'lack of funding/budgetary issues', 'lack of time' and 'lack of staffing/resources' (Polger and Okamoto, 2013, p. 247). To meet challenges, overcome obstacles and win over competitors, librarians play a key role in effectively promoting services and resources and, as such, the role of academic librarians is crucial to ensure this happens. This study confirmed that librarians at UM Library promoted services and resources using a variety of effective promotion techniques such as engaging users through the use of internet and social media network, face-to-face events, user education and display and exhibitions to promote services and resources. Future research will focus on how often librarians use these techniques and other effective techniques for promoting services and resources and the influencing factors, and on more promotion-related questions such as what to promote and how to evaluate promotional activities in the digital age.

Recommendation

The following recommendation was made to enhance the quality of marketing library and information's services in academic libraries. Libraries ought to formulate a marketing plan along with yearly budget so that every book can get its reader and every reader can have his or her book. Librarians must ensure that they put in more efforts in the aspect of marketing and promotion of their resources and services through advertisement, exhibitions and displays, publicity, public relations. Therefore, the marketing policy of the UM Library needs 'careful planning, structuring, execution and evaluation with regular review'. Libraries are growing organization where resources and manpower increasing day by day so marketing strategies / tools must need to promote library services among the users as well as their organizational development.

References

- Abiola, A. K. (2016). Ranganathans law of Library Science: A guiding principle for marketing library services. *Review Pub Administration Manag* 4(178). Retrieved from doi:10.4172/2315-7844.1000178
- Aina, L.O. (2004). Library and information science test for Africa. Ibadan: Third World information services.
- Arachchige, J. J. G. (2005). An approach to marketing in special and academic libraries of Sri Lanka: A survey with emphasis on services provided to the clientele. Retrieved from <http://eprints.rclis.org/6731/>
- Carrington A (2005). Use of posters in Exhibition. Melbourne: Success press.
- Cleeve M (1995). Taking a stand: The market realities of exhibition and display work. *Librarian Career Development*, 3 (1), 31-35. Retrieved from at <http://dx.doi.org/10.1108/09680819510076659>
- Edoka, B. E. (2000). Introduction to library science. Onitsha: Palma publishers.
- Fields, E. (2010). A unique twitter use for reference services. *Library Hi Tech News*, 27(6), 14-15.
- Garcia-Milian, R., Norton, H., & Tennant, M. (2012). The presence of academic health sciences libraries on Facebook: The relationship between content and library popularity. *Medical Reference Services Quarterly*, 31(2).
- Hendrix, D., Chiarella, D., Hasman, L., Murphy, S. & Zafron, ML. (2009). Use of Facebook in academic health sciences libraries. *Journal of the Medical Library Association*, 97(1), 44-47.
- Islam, S. K. M. (2004). The roles of libraries and education. *Information society today*, 1(1), 48-51.

- Kaur, A. (2007). Marketing of information services and products in University Libraries of Punjab and Chandigarh (India): An exploratory study. *Electronic Journal of Academic and Special Librarianship*, 8(3). Retrieved from http://southernlibrarianship.icaap.org/content/v08n03/kaur_a01.html
- Katz, W. (1999). Introduction to reference works: Basic information source. New York: McGraw-Hill.
- Madhusudhan, M. (2008). Marketing of library and information services and products in university libraries: A case study of Goa University Library. *Library Philosophy and Practice (e-journal)*. 175. Retrieved from <http://digitalcommons.unl.edu/libphilprac/175>
- Milstein, S. (2009). Twitter for libraries (and librarians). *Computers in Libraries*, 29(5), 17-18.
- Odine, R. O. (2011). Marketing library and information services in academic libraries in Niger state.
- Polger, M. A., & Okamoto, K. (2013). Who's spinning the library? Responsibilities of academic librarians who promote. *Library Management*, 34(3), 236-253.
- Rodzvilla, J. (2010). New title tweets. *Computers in Libraries*, 30(5), 27-30.
- Bharadwaj S, Sharma A. Marketing and promotion of library services ICAL 2009. *Advocacy and Marketing*, 461-466.
- Schaeffer, M. (1991). Library displays handbook. New York: H. W. Wilson.
- Stuart, D. (2010). What are libraries doing on twitter? *Online*, 34(1), 45-47.
- Williams, L. (2011). Exhibitions in libraries: The role of the information professional. (Unpublished master's thesis). University of Sheffield, Sheffield, United Kingdom.
- Universiti Malaya. (2019, Feb 12) Laporan tahunan Universiti Malaya 2017. Retrieved from [https://www.um.edu.my/docs/default-source/about-um_document/media-centre/annual-report/ltum18-final3-\(2\).pdf?sfvrsn=2](https://www.um.edu.my/docs/default-source/about-um_document/media-centre/annual-report/ltum18-final3-(2).pdf?sfvrsn=2)
- Zanaria Saupi Udin. (2019). *A circulation study at the Central Library, University of Malaya*. Unpublished manuscript.

Author Information

Siti Juryiah Binti Mohd Khalid

Central Library, University of Malaya
Pantai Valley, 50603 Kuala Lumpur, Malaysia
Contract E-mail: sitijuryiah@um.edu.my

The Eurasia Proceedings of Educational & Social Sciences (EPESS), 2019

Volume 13, Pages 60-63

ICRES 2019: International Conference on Research in Education and Science

Mind Mapping as one of the Ways of Creative Thinking

Dagmar RUSKOVA

Slovak University of Technology Bratislava

Lubica VASKOVA

Slovak University of Technology Bratislava

Abstract: Patterns of the thinking process affect not only the success of students at school, but, more importantly, they affect the success of a person in his or her professional and personal sphere. According to the fact that today the availability of information and their volume grow geometrically, it is extremely important to learn how to deal with overloading of information. From this point of view, it is desirable to human nature to be identical to human cognition, which unambiguously exceeds only the ratio itself. Human wisdom is externally demonstrated by the culture of thinking. The ability of impartial judgment, the ability to predict, observe, assess and evaluate phenomena belong to the basic characteristics of thinking culture. One of the primary prerequisites for the quality of complementary thinking is the ability to uncover relationships, compare them in connections and generalize them appropriately. This "versatile" assessment, which is denoted as critical thinking, can be learned through the application of mind or cognitive maps. The article presents the experience of authors with the preparation of future teachers of technical subjects not only with the application of these maps in the process of teaching, but also with their elaboration by the students.

Keywords: Education, Mind map, Information

Introduction

One of the basic strategies of today's school is to address students' self-regulation. Autonomy of students, responsibility for organizing their work is one of the decisive prerequisites not only for quality and effective work of students in the educational process, but also, and above all, a prerequisite for success in the professional performance of contemporary students in perspective. An important determinant of success in the future is permanent, lifelong learning. Want to learn and know how to learn effectively is more important from the perspective of the future than what the student learned at school during the educational process. Therefore, learning-related competences - learning competences - belong among the key competences of school leavers today.

Many variables, which precise or exhaustive identification is more or less impossible, influence the quality of the work of students. Nevertheless, every good teacher can identify the factors that constitute the modus operandi of the meaningful and successful work of the student in the reality of the educational process. Factors essential to the success of students include:

- Ability to identify problems and strategies for solving them
- Ability to take into account degree of own past experience
- Ability to put things into context and organize own intellectual capital
- Consciously accept responsibility for own learning
- Meaningfully organize own learning process.

In this context, arises the question- in which area of competence can teachers make a significant contribution to their improvement. How should be the teacher-student interaction, how should the teachers grasp it so that its result will be the enhancing the quality of students' learning skills? Learning skills are a set of partial activities that a student applies during learning process. They can be considered as universal skills – the ability to

- This is an Open Access article distributed under the terms of the Creative Commons Attribution-Noncommercial 4.0 Unported License, permitting all non-commercial use, distribution, and reproduction in any medium, provided the original work is properly cited.

- Selection and peer-review under responsibility of the Organizing Committee of the Conference

© 2019 Published by ISRES Publishing: www.isres.org

independently acquire process, evaluate and apply information as a basis for performance, success and later professional expertise. In the spectrum of learning skills, the scientific literature identifies three basic areas:

- Skills related to preparation for learning – e.g. selection of information from various sources, creation of optimal conditions for learning,
- Skills related to the actual implementation of learning – to process information, to be able to make notes, to memorize, to rationally learn from text, to solve algorithmic, but especially problem tasks, etc.
- Skills related to control of learning – preparation for exams, handling hectic and stress in the examination period, having a real picture of the quality and quantity of own knowledge and skills, etc.

The fact that learning skills are a decisive factor in the success of students is evidenced by the multiple literature reviews that poor quality learning skills or incorrect study methods and habits are not only the cause of study problems, but also the cause of complete failure and early school leaving. The most of the problems occur in the first year of study, while intelligence is of little significance for early school leaving. Good students of engineering are distinguished from less good ones by, among other things, effective learning habits, e.g. the more successful they were, the less work they postponed and the success in the study in the first semester was dependent on the way in which the lectures were written and the time schedule of the study, time management.

Research confirms that learning skills, learning habits, or subjective study methods are partly a prerequisite for success. Some researchers even consider good learning habits essential for study success. They found that the relationship between study methods and learning outcomes was closer to those who thought about their learning styles (according to Laucken, Schick, Höge, 1999, p. 185). Students who voluntarily participated in the program, which led them to an effective and meaningful change in their learning habits or skills, ranked better than before and better than other students in the following semesters.

Results and Discussion

We are convinced that even at university, it is not possible to leave students with their study problems on their own. This conviction leads us to find such ways of teaching that help students to develop their learning skills. One of the meaningful ways is to apply mind maps that develop students' ability to put terms or facts into relationship and help them to meaningfully organize their intellectual capital.

In addition to this feature, mind maps open an attractive, fun and meaningful way of learning. Why?

If the teacher motivates the student to knowledge, by introducing the knowledge as a value itself, the attitude of students to such knowledge is lax, indifferent, or even refusing. And even if one realizes that knowledge gives chances for a true picture of reality. However, if the teacher mentions knowledge as a mode of power or force, at that moment the attitude of the learner's changes because they realize that by knowing one can grasp reality and give it the desired contours. If knowledge gives the chances of power, the learning process (which results in knowledge) is given a positive attitude.

Mind maps are thus a suitable bridging and unifying factor of two attributes of the educational process - learning as a process and knowledge as a result. If the teacher is able to "insert" the mind map into the teacher-student interaction, the mind maps become at the same time an extremely strong motivational charge.

In the subjective consciousness of students, mind maps create suitable chances for penetration of a substantial and functional. Variability or relational dependence in consciousness is open during the mind mapping, they are accessible to modifications, and continuity is almost without any fixation. This makes mind maps not only the source of student's activity and independence, but above all the source of discovering with the dominance of student creativity. Moreover, the aesthetic message of mind maps is an added value of cultivating the student's personality.

The above analysis of conceptual maps can be specified in the following statements:

- They allow divergent thinking
- They enable speeding up the slow way of "talk" with reality
- They are a progressive experiment in the subjective world of knowledge
- They are the driving force of bidirectional projection: from themselves to reality and from the reality of the world to themselves

- They give a subjective dimension of individuality of person to thinking
- Activate not only cognition but also emotions, dreams, effort, vision, imagination, generosity, courage etc.
- They are articulation of that, what we cannot say accurately
- They allow such a modality of knowledge, in which the elements of description), explanation) and prediction are intertwined
- They bridging between conscious and unconscious cognition, i.e. they are using both hemispheres of the brain (which is extremely important for the technically oriented students)
- They are a magical way of learning
- They enable to exceed contours of rationality
- They elevate knowledge to a positive value
- Their outcome is not only the quality of critical thinking, but also the power of creative intelligence.

In the framework of the supplementary pedagogical education, after which engineers-technicians acquire pedagogical competence as technical subjects teachers at secondary schools, we applied mind mapping in the subject *Innovation in the field of study*. It is a subject in which the content of technical subjects is interconnected with contents of subjects from pedagogy, psychology and didactics of specialized subjects. It is a subject that is primarily based on the significant penetration of two different worlds - the world of rationality and emotionality.

The results of mind mapping can be summarized as follows:

- The line of vertical and horizontal relationships between terms will change
- There is a transfer of concepts from one hierarchical level to another
- Qualitatively new conceptual links are established
- Relationships of superiority, coherence, inferiority absorb new concepts
- Working with mind maps raises a gradual integration that creates thought compliance
- What seemed to be incompatible and contradictory, to the learner is gradually and logically interconnected by the application of mind maps
- Structure of concepts, conceptual network becomes coherent (internally consistent)
- Improving differentiation and discrimination
- Refinement of the technical and pedagogical-psychological-didactic line
- The subjective knowledge structure is cleared (crystallized), becomes more sophisticated and versatile
- More sensitive distinction of meanings of terms in different contexts
- Finding new connections between declarative and procedural knowledge
- Unconscious and meaningful linking of explicit and implicit knowledge - metacognition
- Strengthening of thinking elements that externally represent clarity, accuracy, certainty, substance, depth, width and logic.
- Strengthening critical thinking quality elements
- Gradual transformation and interiorization of the contents of the concepts of technical sciences and pedagogical-psychological-didactic sciences into a mutually consistent subjective system

Conclusion

Man is constantly changing, in something he adds, in something he rejects. Assimilation and adaptation is one of the important conditions for the functioning of every human being. We believe that learning skills as one of the essential components of key competences can be accepted as a significant determinant of the degree of assimilation and adaptation of an individual to the environment. In addition to professional, technical disciplines, a wide range of subjects and factors are involved in shaping the technical skills of future engineers. i.e. the subjectivity aspect, starting with the development of perception, cognition, continuing memory, through language, creativity, communication, to social hierarchy and identity creation. Mind maps are strong and meaningful contribution to the subjectivism aspect, with the dominance of the desirable transfer. Their final result is a positive reinforcement of the student in his continuity and dynamics.

The need of a true, authentic essence of each teacher's culture and expertise of every teacher is evident from the time we live. "The plain fact is that the planet does not need more successful people. But it does desperately need more peacemakers, healers, restorers, storytellers, and lovers of every kind. It needs people who live well in their places. It needs people of moral courage willing to join the fight to make the world habitable and humane. And these qualities have little to do with success as we have defined it." (David W Orr). The realization of this profound thought needs a teacher, without poetic and heroic acts. A teacher who does not forget to ask questions. The answers to the questions are sometimes straightforward and simple, sometimes

complex, difficult and sometimes painful. And some questions remain unanswered. Perhaps the absence of answers in the future will be a spark of long-term resonance (flow), positively determining the views, thoughts and attitudes of its students. Students whose *modus vivendi* is a change in the values of this world.

References

- Laucken, U., Schick, A., Höge, H. *Úvod do studia psychologie*. Praha: ISV, 1999. 214 s. ISBN 80- 85866-41-2.
- Turek, I., *Základy didaktiky vysokej školy*. Bratislava. STU, 2006. 248 s. ISBN 80-227-2573-0.
- Belz, H., Siegrist, M. *Klíčové kompetence a jejich rozvíjení*. Východiska, metody, cvičení a hry. Praha. Portál, 2001. ISBN 80-7178-479-6.
- David W. Orr, *Ecological Literacy: Educating Our Children for a Sustainable World*
<https://www.goodreads.com/work/quotes/883586-ecological-literacy-educating-our-children-for-a-sustainable-world-the>
- Ruissel, I. *Inteligencia a myslenie*. Bratislava: Ikar, 2004. 432 s. ISBN 80-551-0766-1.

Author Information

Dagmar Ruskova

Slovak University of Technology
Institute of Management
Supplementary Pedagogical Education
Vazovova ul 5.
812 43 Bratislava
Slovak Republic
Contact E-mail: dagmar.ruskova@gmail.com

Lubica Vaskova

Slovak University of Technology
Institute of Management
Supplementary Pedagogical Education
Vazovova ul 5.
812 43 Bratislava
Slovak Republic

Observing the Impact of Science Education on Undesirable Behaviors of Students in the Agent-based Simulation Environment

Sebnem BORA
Ege University

Gizem CENGİN UNUVAR
Manisa Celal Bayar University

Sevcan EMEK
Manisa Celal Bayar University

Abstract: Agent-based modeling is a new computational model for social sciences. Computational models are formulated as computer programs which represent the processes that exist in the social world. When simulations of these computational models for social sciences are performed, it is possible to gather information about real systems' processes and predict future outcomes of the processes. The agent-based model includes a set of agents that represent real actors in a real system in the simulated environment. The simulated environment represents the environment in which the agents contain their resources and perform their actions. Agents interact with other agents and entities in the environment while they try to achieve their individual goals. In the present study, it is aimed to imitate the school environment in a simulation environment by using the Repast Simphony 2.4 simulation tool and observe the impact of science education on undesirable behaviors of students represented by agents in the simulation environment.

Keywords: Education, Agents, Simulation

Introduction

Agent-based modeling is a computational method, which has become increasingly popular to model complex systems in a wide range of applications, such as in the social sciences (Conte & Paolucci, 2014; Epstein, 2007; Klein, Marx & Flschbach, 2018; Tesfatsion & Judd, 2006); since a modeler can build models where individual entities and their interactions are directly represented. In this method, developed models are created as computer programs which are having inputs and outputs that can be considered as independent variables and dependent variables, respectively. These programs represent the processes considered to occur in the real social world. For example, in a school, it is possible to examine students' interactions with each other and their teachers in a simulation environment where the teacher and students are programmed as agents.

The agent-based model is a model in which agents are used to understand the social world. The social phenomenon that will be modeled in an agent-based modeling should be clearly represented in the computer program. In this modeling method, it is possible to define models directly in the form of autonomous individuals, i.e., agents and their interactions (Macal and North, 2009). It is seen that the rule-based individual behaviors of the agents at the micro level and the interaction between agents are likely to reveal the behavior of a social community at the macro level. Therefore, agent-based modeling is often used to capture the complexity of individuals in dynamic settings. It is also possible that the results of the tests carried out on an agent-based model of a social phenomenon are similar to the behavior of the real systems if the model is a successful model. Sometimes it is possible that the results do not reflect the real social phenomenon of the model. In this case, the behavior of the model can be observed by running the tests on the agent-based model with different inputs.

Although, agent-based modeling and simulation is adopted to use in many social science applications, this method has not been applied much in education research. In this study, the role of agent-based modeling and simulation in education is explained through the peer victimization model for education researchers. Thus we aim to describe possibilities of observing undesirable behaviors, such as school bullying in a virtual school environment by using an agent based modeling and simulation. Bullying is defined as a phenomenon that occurs as undesirable behaviors and repetitive negative actions among school aged children. Bullying involves dynamic and negative interactions that are focused on hurting, making threats, harming peers from a group on purpose (Bilgili, Kocaoğlu & Akin, 2016; Gökkaya, 2016). Our model developed will be used to provide a better understanding of the dynamics of school bullying and create a social training environment to educate young teachers without handling unruly students. Thus the teacher may face some sorts of situations and problems in a virtual classroom populated with student agents as if he/she is in a real classroom.

In this paper, we present our model for peer victimization in schools in detail. The principal way in the model we propose is relatively simple: we identify simple rules for interactions between students. Our purpose in this regard is to offer a system that is as simple as possible through a bottom-up modeling approach. The remaining sections of this paper are organized as follows. The section titled “Undesirable Behaviors and Bullying” provides background information detailing the undesirable behaviors in classrooms. The section titled “Method: Agent-Based Modeling and Simulation” presents a brief explanation of the fundamentals of agent-based modeling and simulation. The section titled “Agent-Based Modeling and Simulation of the Peer Victimization” introduces the agent-based peer victimization model. The section titled “Experimental Study” illustrates the experimental model developed for the study, presents the data, our analysis, and a discussion of the approach we used. The conclusion section presents a summary of this research study.

Undesirable Behaviors and Bullying

Student behavior that interferes with classroom management, such as disrupting education and training in the classroom, distracting the attention of all students and disturbing the peace of the class, sometimes bringing about permanent discipline problems, and spreading among other students is called undesirable student behavior.

According to the Cengin Ünüvar (2014) research findings, the behavior problems seen in primary school are:

- Drawing interest conducted misbehavior: Unnecessary speech, complaint, speaking without permission, moving around, dealing with other things, psychological violence, inappropriate expression of emotion, making inappropriate statements.
- Problem behaviors to avoid rules: Not to bring the lesson equipment, to remain unresponsive, to delay the lesson, to litter, to escape from group activities, spitting, copying in the exam
- Problem behaviors due to expression of anger: Suddenly come out of class, stop talking to the teacher, physical violence.
- Problem behaviors due to physiological development problem: Eating under the desk, peeing on pants in the classroom.
- Problem behaviors due to the lack of love and interest: Taking someone’s belongings without his/her permission, theft.

Undesirable behaviors such as complaints, psychological violence, improper expression of emotion, improper discourse, spitting, physiological violence, theft, unauthorized taking of friends’ belongings are called bullying if these behaviors are repeated to the same students.

Pişkin (2002) examined the definition of bullying and he defined “bullying” as a sort of aggressiveness in which one student intentionally and continuously disturbs the students who are weaker than themselves, and the victims are unable to protect themselves.

According to Pişkin (2002) school bullying can be physical, such as kicking, slapping, pushing, pulling, teasing; it can be verbal, such as mocking, teasing, annoying naughty noun, humiliating words; and it can be indirect, such as spreading the gossip and rumor, leaving the victim out of the group of friends and leaving him/her to loneliness; it can also emerge as behavioral, such as taking money and possessions, threatening to take money and possessions, damage to belongings.

In order to define an action as bullying, it is necessary to have four basic criteria (Gökler, 2009):

- Intentionally harmful
- It occurs repetitively.
- There is a physical or psychological power imbalance between the bully and the victim.
- The victim feels himself/herself helpless and is unable to defend himself against bullies.

Bullies often lack problem solving skills and tend to externalize their own problems. Generally, bullies' school successes are low. The victims take on the most difficult role in the bullying process. One of the most fundamental characteristics of the victims is that they are more anxious and unsafe than other students (Gökler, 2009). They are generally cautious, sensitive and silent. When they are attacked by other students, they usually respond in the form of crying and withdrawal, especially in small class levels (Yıldırım, 2012).

Bullying is resistant to time and negative effects may occur especially in adulthood. Children who exhibit aggression against their peers in their childhood are also more likely to exhibit behaviors such as domestic violence, crime and substance use in the later years. Children who are exposed to chronic bullying, they may experience physical problems, psychological stress, concentration difficulties and school phobia in short term. In the long term, they may not develop and maintain a healthy relationship with the opposite sex and may experience high levels of depression and develop a highly negative self-concept according to their peers who are not subjected to bullying (Gökler, 2009).

If individuals are physically, mentally and socially healthy in a society, then that society is healthy. It is necessary to direct the bullies and their victims, who carry a risk for the society, to science and make use of the rehabilitative effect of science. Because dealing with science is to find the source of the problems, to see the parts as a whole, and to be curious. Science allows us not to escape from problems by being patient and committed and it allows us to dream, to be creative. To deal with science gives an interdisciplinary approach to a person causes an individual to look at events in a multi-faceted way. These children can be given the opportunity to learn computer programming language and make their own computers.

Programming has a close relationship with mathematics, science and technology design. With this method, students can visualize real life problems in computer environment and seek solutions to problems, thus learn to think using algorithmic and logic, understand the common language between machine and human and use what they learn in solving real-life problems. Their computer skills improve. They learn to think abstract, develop their creativity, and become a self-confident individual.

Method: Agent-based Modeling and Simulation

An agent-based model and simulation consists of agents, simulated environment, and simulation environment. The actors of the real system are defined as agents in an agent-based model. Based on the definition of agents made by different researchers, an agent is a software system that acts with a certain degree of autonomy, perceives the changes in its environment and re-evaluates its knowledge according to its perceptions, plans, and interacts with other agents and its environment. This definition determines the features that should be present in the agents and it concerns the people who develop the agent development platforms in computer science. However, these features are not very useful when designing an agent in agent-based modeling and simulation. When defining agents, it is possible to make it easier to design agents using perception, performance, memory, and policy features. Agents perceive the environment in which they are located, that is, the presence of passive objects and agents located in their neighborhoods, and they move around in their environment, communicate with other agents and interact with their environment. Agents can record perceptions of previous states and actions. They have a set of rules, intuitions, or strategies that determine what behaviors they will perform, taking into account their current situation and background (Badham et al., 2018).

The agents are model components that are affected from and influence the simulated environment and the simulation environment. The agents perform their actions in the simulated environment. As a result of the actions of agents, other agents in the simulated environment may also be affected. The simulated environment is composed of active and passive components that cannot be represented as agents, and these components and agents represent the real environment when creating the simulated environment. For example, the simulated environment may represent a geographic area, for example a city and its characteristics, or countries and nations depending on international relations.

The simulated environment also forms the communication channel between agents. Directing all communication between agents through the environment not only corresponds to the natural way, but also to the role of the environment in human relations, but also makes it easier to track the agents.

The simulation environment presents the simulation infrastructure for operating the simulated environment model including the agents. The simulation environment is part of the simulation model that it gives services such as messaging, runtime information, running the simulation and keeping results. The interactions between the agents and the simulated environment during the simulation can produce undefined behaviors in the simulated environment over time. This is called emergence.

Most of the time, simulations use time steps as the concept of time. Each time step is set as the same simulation time. In a simulation step, each agent in the model exhibits its behavior by conducting an action, interacting with other agents or interacting with other components in the environment. In the next section, we explain our agent-based peer victimization model in detail.

Agent-based Modeling and Simulation of the Peer Victimization

We will be building a simple agent-based model involving bullies chasing students (victims) and students running away from bullies. The agent-based modeling and simulation of the peer victimization has three main components: agents, a simulated environment, and a simulation environment. This study has limited parameters such as agents' types, agents' attributes. The bullies and students are the agents of the model. They have attributes and rules and they respond to changes in the environment. The aggression energy, which is an attribute of the bully and student, defines the extent of the aggressiveness. Whereas bullies engage in physical or verbal bullying to some students, those students become victims. Victims may not fight bullies; they mostly prefer to stay unresponsive. These influence interactions among agents of the model and between agents of the model and the simulated environment.

The simulated environment in the model consists of a grid with 50×50 grid cells to represent the school environment. Each grid cell provides a suitable environmental layer for bullies to intentionally cause harm to victims. In this study, we used Repast Symphony 2.4 to create agents that are written using Java programming language. After we identify the agents in the simulated environment, it is necessary to explain the behaviors of the agents.

Bully Behavior

At the initialization, the programmer sets the number of bullies to create for the simulation. The bullies are created and randomly assigned aggression energies of between 15 and 30. Each bully is randomly distributed on the virtual school environment (simulation environment) represented by a grid with 50×50 grid cells. The bullies' behavior is to wander around looking for victims to attack physically or verbally. Each time step of simulation, each bully will determine where the most students are within its neighborhood and move there. When a bully has discovered the location with the most students that bully wants to move towards that location. All the students at the bully's grid location are obtained and a student is chosen at random from these students. The bully attempts to harm the student at that location and consequently, that student will become a victim. The attacking behavior is repeated, or has the potential to be repeated, over time to the same victims or other new victims.

When a bully attacks a student, the bully takes a task for a certain period of time. As he/she continues to take the tasks, his/her aggression energy decreases. When the bully's aggression energy decreases under a certain value, he/she stops bullying.

Student Behavior (Including Victims and Bystanders)

At the initialization, the programmer defines the number of students to create for the simulation. Students are created and randomly assigned the aggression energies between 4 to 10. Students are randomly distributed in the grid. The basic behavior for a student is to move around randomly and react when a bully comes within its local neighborhood by running away from the area with the most bullies. His aggression energy increases in the attack of the students who act undesirable behaviors (i.e., bullies).

Experimental Study

We performed three experiments in order to observe the impact of science education on undesirable behaviors of students in the agent-based simulation environment. First, we run our simulation when the number of bullies is less than the number of students. Then, the number of bullies is equal to the number of students. Lastly, we run the simulation when the number of bullies is larger than the number of students.

Experiment 1: The number of bullies is less than the number of students

In this experiment, simulation runs with the students exhibiting undesirable behaviors, such as bullying around the students with good behaviors. The behaviors of all students are defined by aggression energy. At the initial time step, a settlement of bullies accrued that ranged in terms of aggression energy from 15 to 30 in the simulation environment. Also, students of acting good behaviors accrued that ranged in terms of aggression energy from 4 to 10. The aim is to distract the bullies by giving them a science task. As illustrated in Figure 1, bullies are represented as red, students exhibiting good behaviors are represented as blue.

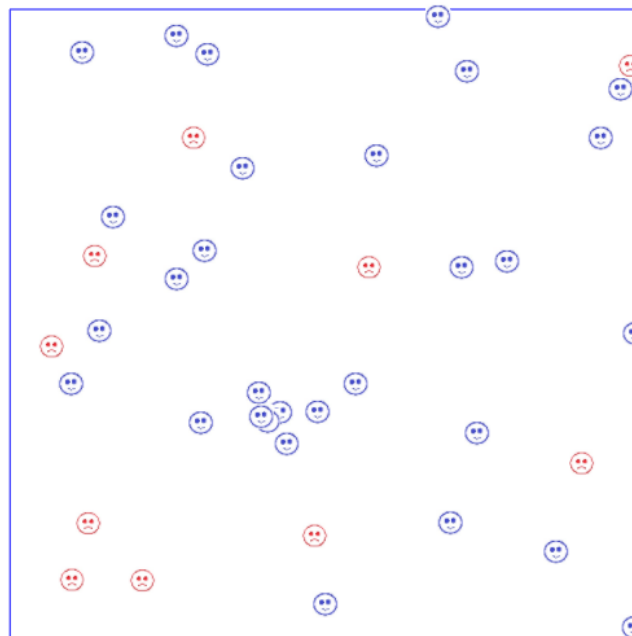

Figure 1. Students and bullies randomly distributed in the simulation environment

The aggression energies of 10 bullies and 200 students are shown in Figure 2. Until the 210th tick count (time step), the mean of aggression energies of bullies decrease whereas the mean of aggression energies of students increase, as we expected. Because students will have an increase in aggression energy as long as they are attacked. When the bullies take science projects, their aggression energies decrease and reach at energy levels such that they never involve dynamic interactions between the victims. After the 210th time step, the mean of aggression energies of bullies and students reach constant values.

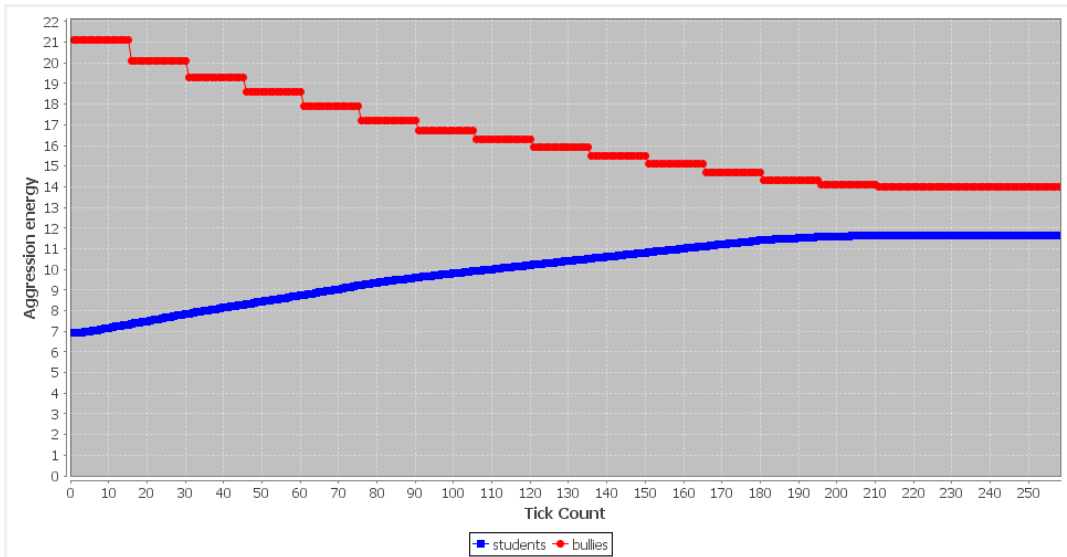

Figure 2. The aggression energy if the number of bullies is less than the number of students

Experiment 2: The numbers of bullies is equal to the numbers of student

In order to study the impact of bullying on the obedient students and the impact of giving science tasks to the bullies, a similar experimental setup as described in experiment 1 was performed. Thus 200 bullies with aggression energies ranging from 15 to 30 and 200 students with aggression energies ranging from 4 to 10 were created in the simulation environment.

When a student is attacked, his/her aggression energy increases in the attack of the students who act undesirable behavior. Therefore, we observed the increase in the mean of aggression energies of students, as seen in Figure 3. At the 32nd tick count, the mean of aggression energies of student reaches the mean of total aggression energies of bullies and it continues to rise. After the 225th tick count, the mean of the aggression energies of bullies and the mean of aggression energies of students reach minimum and maximum values, respectively, and they remain constant at those values.

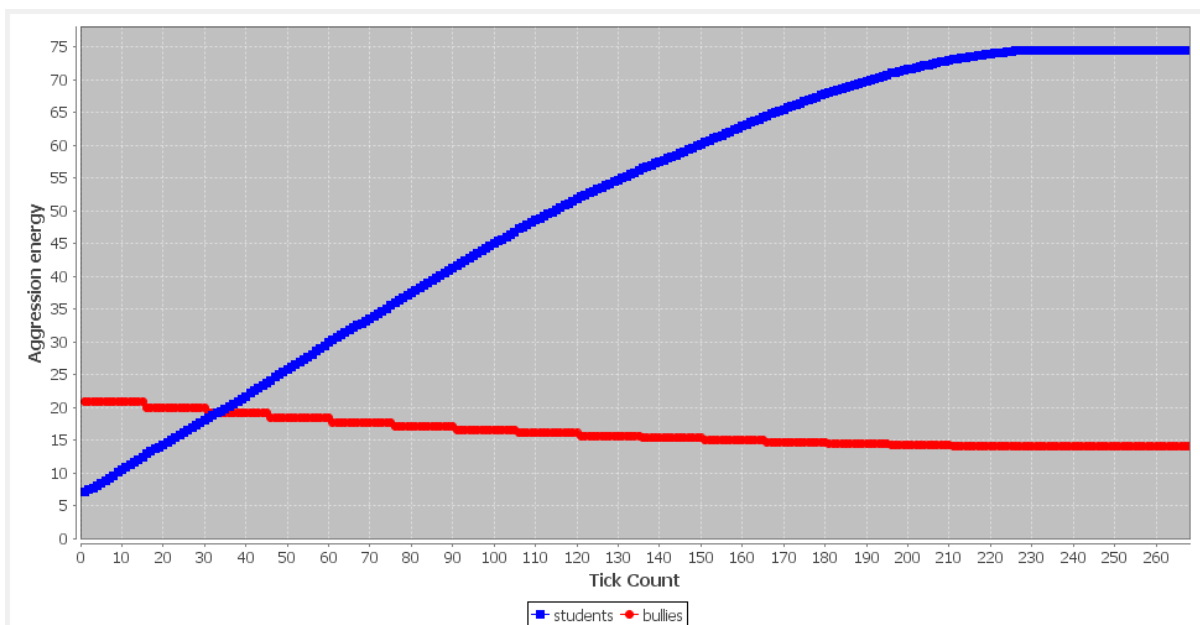

Figure 3. The aggression energy if the number of bullies is equal to the numbers of student

Experiment 3: the number of bullies is larger than the number of students

In order to observe the effect of bullying on the obedient students and the impact of science projects on the bully students, a similar experimental setup as described in experiment 1 and experiment 2 was performed. Thus 200 bullies and 10 students with aggression energies ranging from 4 to 10 were created in the simulation environment.

The graph in Figure 4 shows the mean of aggression energies of the students and the mean of aggression energies of bullies. We observed the increase in the mean of aggression energies of students, whereas we observed the decrease in the mean of aggression energies of bullies, as seen in Figure 4. In this experiment, the number of bullies is very high; therefore, it causes the victims to increase in the number as well. Compared to the experiment 2, the mean of aggression energies of the students reaches the mean of aggression energies of the bullies at the 18th tick count and it continues to rise until the mean of aggression energies of bullies decreases under 15 and remains constant.

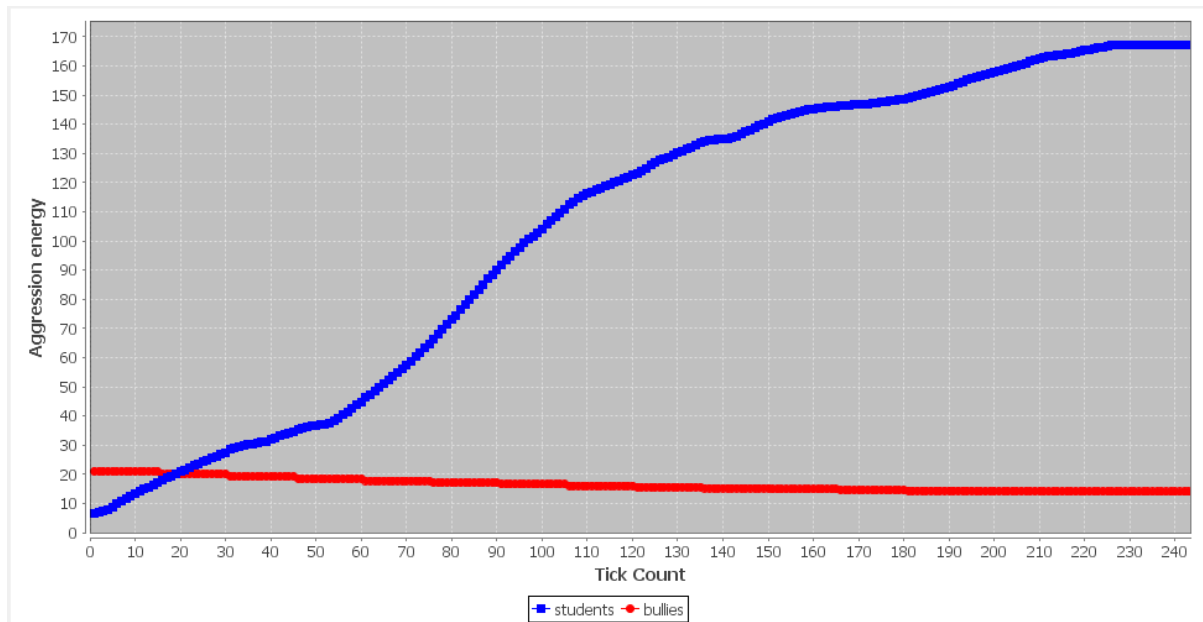

Figure 4. The aggression energy if the number of bullies is larger than the number of students

Conclusion

Agent-based modelling and simulation is a computational method for studying complex systems that it has been used with success in many social sciences. However, this method has not been used much in the field of education. In the present paper, we explained the agent-based modelling and simulation method through modeling of an undesirable behavior involving physical and psychological violence in school environment and we proposed to observe the impact of science education on undesirable behaviors of students by using this model. We presented challenges for applying Agent-based modelling and simulation in the field of education since this study is an interdisciplinary study, thus some difficulties can arise in creation of a system's engineering scenario. Moreover, we discussed some of the potential benefits, such as providing a virtual school environment where a young teacher could train for handling students with undesirable behaviors by playing the role of a teacher.

In our model, we observed bullying acts as an undesirable behavior faced in our virtual school environment. The aggression energies of bullies would decline when they achieved their science projects in the model. Our model is not currently being developed to monitor all undesirable behaviors in the school environment. With the improvement of the model, it will be ensured that a virtual environment will be realized to monitor the activities that disrupt the discipline of the virtual school environment. Thus by using this model, the teacher could explore some sorts of situations and dilemmas that she/he might encounter in the real world.

References

- Badham, J., Chattoe –Brown, E., Gilbert, N., et al. (2018). Developing agent-based models of complex health behaviour, *Health and Place* 54, 170-177.
- Bilgili, N., Kocaoğlu, D., & Akin, B. (2016). Peer Bullying Among High School Students and Related Factors, *Yeni Symposium, A Journal of Psychiatry, Neurology and Behavioral Sciences*, 54(3), 10-17, Doi:10.5455/NYS.201512210252540
- Cengin Ünüvar, G. (2014). *Unwanted behaviors of elementary school students in class that exhibits this behavior demonstration of frequency and relationships with parents attitude*, (MA dissertation), Manisa Celal Bayar University.
- Conte, R., & Paolucci, M. (2014). On agent-based modeling and computational social science, *Frontiers in Psychology*, Hypothesis and Theory Article, 5, Article 668, doi: 10.3389/fpsyg.2014.00668
- Epstein, J. M. (2007). *Generative Social Science Studies in Agent-Based Computational Modeling*. 3th ed. United Kingdom: Princeton New Jersey, p. 384.
- Gökkaya, F. (2017). Peer Bullying in Schools: A Cognitive Behavioral Intervention Program, *Child and Adolescent Mental Health*, *Martin H. Maurer, IntechOpen*, DOI: 10.5772/66701. Available from: <https://www.intechopen.com/books/child-and-adolescent-mental-health/peer-bullying-in-schools-a-cognitive-behavioral-intervention-program>
- Gökler, R. (2009). Peer bullying in schools, *Journal of Human Sciences*, 6(2), 511-537.
- Klein, D., Marx, J., & Fischbach, K. (2018). Agent-Based Modeling in Social Science, History, and Philosophy. An Introduction. *Historical Social Research* 43 (1): 7-27. doi: 10.12759/hsr.43.2018.1.7-27.
- Macal, C., & North, M. J. (2009). Agent-based modeling and simulation: *In Proceedings of the 2009 Winter Simulation Conference* (ed M. D. Rossetti, R. R. Hill, B. Johansson, A. Dunkin, and R. G. Ingalls), Austin, Texas, 13, 86-98 Piscataway, New Jersey: Institute of Electrical and Electronic Engineers, Inc.
- Pişkin, M. (2002). Okul zorbalığı: Tanımı, türleri, ilişkili olduğu faktörler ve alınabilecek önlemler. *Kuram ve Uygulamada Eğitim Bilimleri / Educational Sciences: Theory and Practice*, 2 (2), 531-562.
- Tesfatsion, L., & Judd, K. L. (2006). *Handbook of computational economics*. In Leigh T. and Kenneth LJ (eds.) agent-based computational economics, 1187-1233
- Yıldırım, R. (2012). Peer bullying, *Manisa Celal Bayar Üniversitesi Sosyal Bilimler Dergisi*, 10(2), 40-48

Author Information

Şebnem Bora

Ege University
35100 Bornova, İzmir, Turkey
Contact E-mail: sebnem.bora@ege.edu.tr

Gizem Cengin Unuvar

Manisa Celal Bayar University
45140 Manisa, Turkey

Sevcan Emek

Manisa Celal Bayar University
45140 Manisa, Turkey

Mixing Languages in the Spoken Discourse of the Algerian Radio Broadcasters: a Strategy for an Effective Communication

Horiya AMAR BEKADA
University of Oran 2

Soraya HAMANE
University of Oran 2

Abstract: Mixing between many languages and varieties constitutes the strategy of communication adopted by the Algerian radio broadcasters to address people from different backgrounds. This paper sheds light on the particularity of this mixed code which; in addition to Arabic language; contains borrowed words from other languages especially French, Spanish and Turkish words. These words, which are spoken and rarely written, slipped into the oral speech of the Algerian radio broadcasters, some being adapted morphologically and phonologically and others being used with no modification. Mixing between all these languages gives birth to a specific variety of Arabic called Algerian Arabic which is understood by everyone. On the basis of various spoken texts involving mixing between the languages already cited, this paper stresses then the historical and socio-cultural factors responsible for this language contact situation in which Algerian radio broadcasters do not use what could be called pure Arabic. It is suggested to maintain this particular code in the spoken discourse of the Algerian radio broadcasters because it reflects the Algerian history, culture and identity.

Keywords: Arabic varieties, Algerian Arabic, Language contact, Code mixing, Communicative strategy

Introduction

Language is a uniquely human phenomenon. Either spoken or written, it plays a great role in our daily relationships. It serves a vast range of communicative needs, not just a means of communication but also a marker of social identity. Among the social phenomena that interested to a great extent researchers in the field of sociolinguistics, is the phenomenon of language usage inside the same speech community. However, studies on language contact phenomenon in the media and especially in radio broadcasting stations are scarcer although this sociolinguistic situation is largely spread in such a professional environment especially in Algeria which is regarded as a linguistic market where many languages coexist together in different domains and in various contexts. On the basis that language should be studied and investigated in relation to its social context "speech is not personal possession but a social: it belongs not to the individual but to the members of society". Whitney (1867:404) quoted in (Fatmi: 13-14), this research paper attempts to explore the particularity of radio broadcasters' oral discourse taking into consideration the linguistic diversity of the Algerians' verbal repertoire.

Since Algerian radio broadcasting is a real laboratory for sociolinguistic studies because of radio broadcasters' daily exposure to language mixing phenomenon, the paper at stake accordingly investigates radio broadcaster's ability to mix between many languages in different situations and contexts. This research study comprises data from radio passages with frequent language mixing which will be transcribed to the written form. It is worth noting that the researcher profession as a radio broadcaster for more than eleven years will provide useful insight to the subject matter.

The State of Multilingualism in Algeria

Algeria as a North African country has experienced long-term linguistic and cultural contact with many societies and civilizations. Dynamic and complex bi and multilingual situations and other language contact phenomena have resulted from this linguistic experience. Across history Algeria was noticeably marked by the emergence of several languages; one of the most important effects was the great number of words which slipped into the Algerian verbal repertoire. Due to the complex history the country has gone through, the Algerian speech community has acquired a distinctive code which is characterized by a dynamic speech variation.

About the complexity of the Algeria's linguistic situation, Bagui (2014) points out: "the complexity of the Algerian linguistic situation can be clearly attested in individuals' day-to-day linguistic behaviour. Not only a diglossic situation where two varieties of the same language are in a functional distribution exists (Ferguson 1959), but also a linguistic phenomenon of an inter-lingual situation that occurs when distinct languages are in contact" (p.86).

Nowadays, Algeria's linguistic profile comprises:

Classical Arabic

CA is a variety of Arabic which is acquired through learning in educational institutions and used in formal situations for example in schools and religious speeches. It is perceived as the language of Islamic religion and considered as a high variety of Arabic. Kerma(2017) states: "Classical Arabic enjoys the prestige of a written language, but is no one's mother tongue. It is used by a group of scholars who have always taken great pride in their ability to speak flawless Arabic, and therefore always looked down upon any colloquial interference with the classical forms" (p.134). It is important to note that Classical Arabic has recently undergone a slight shift from classicism to Modern Standard Arabic.

Modern Standard Arabic

Derived from Classical Arabic in order to meet socio-cultural and linguistic needs, MSA is a contemporary variety of Arabic language which is now used in literature, education, administration and to some extent journalism. Said (1967) indicates that Modern Standard Arabic is "that variety of Arabic that is found in contemporary books, newspapers, and magazines, and that is used orally in formal speeches, public lectures, and television". Modern Standard Arabic is used as the official and national language of all Arab countries including Algeria. It is standardized and codified to the extent that it can be understood by different Arabic speakers in the Arab World at large.

Tamazight Language

Tamazight or Berber language is a minority language spoken by some people in different regions in Algeria mostly in kabylia. It has been recognized as an official and second national language in the Algerian constitution of 2016 after years of struggle by Tamazigh advocates. This step attempted to strengthen Algeria's democracy, a starting point to draw up a new map of the nations' identity which consists of a linguistic and cultural diversity. Among the practical measures which have been recently undertaken, the integration of Tamazight into the educational system. More human and financial resources have been attributed to the progressive teaching of Tamazight especially at the primary schools in order to promote the language.

Algerian Arabic

AA is the mother tongue of all Algerians. This colloquial variety of Arabic which has developed many regional varieties in Algeria is considered as a low variety of Arabic for the reason of containing many foreign borrowed words, but still occupies an important stand in the Algerian society. Instead of being exclusively spoken, it is to mention, however, that the written form of Algerian Arabic was used in the 80's and 90's as stated in Bishai(1996) "Desirous of reaching the general public and perhaps also because they had not fully mastered classical Arabic, the speakers of the revolutions have often used colloquial expression in their formal speech". It is also worth noting that the written text of Algerian Arabic still exists in many Algerian news papers .This,

without ignoring the growing tendency to find lexical and structural elements from Algerian Arabic in informal writing such as private correspondences in social media.

It is relevant to adduce here the fact that the two varieties of Arabic (Modern Standard Arabic and Algerian Arabic) remain two distinctive codes especially on the phonological and morphological levels. Phonologically, most MSA vowels are deleted or reduced. Here are some examples:

Table 1. Phonological differences between MSA and AA

MSA	AA	The significance of the word in English
/ʃaʒara/	/ʃaʒra/	a tree
/ʃaf u:zu/	/ʃfu:z/	to win
/təʁrisu/	/təʁrəs/	to plant

Morphologically, AA is much simpler than MSA because of the absence of the case-marking inflections and the plural inflections. Consider the following examples:

Table 2. Morphological differences between MSA and AA

MSA	AA	The significance of the word in English
/ta:baʃtum:ha:/	/tabbaʃtu:ha/	You have followed
/istafadum/	/stfadi:tu:/	You have taken benefit.
/jahummu/	/jhamm/	It interests.

French Language

It is a foreign language which is used in social life and educational domains. French language, although remains the language of the colonizer, is considered in Algeria as the most important language for economic purposes, scientific research and modern culture. Akila affirms: "French has become an elitist language, symbol of social success and remains omnipresent in the fields of the bank of economy and the opening up on the universal". (quoted in Kerma p.138)

All these languages mentioned above are mixed together to form a distinctive code called Algerian Arabic. One may consider that often Arabic speakers from the Middle East do not recognize what has been said by an Algerian; the reason is that Algerian Arabic is largely influenced by many other foreign languages. In Algeria actually, mingling many languages together is a plain fact. It is not surprising that non-educated Algerians use borrowed words without actually mastering foreign languages. This is in fact the result of the historical contact with many languages during the occupation of Algeria. Arabic, Tamazight, Spanish, Turkish, French are all languages which are incorporated into the verbal repertoire of Algerians and used in their daily interactions. The aspects of language mixing situation in the Algerian society occurs thus as a natural outcome of language contact due to the historical and socio-cultural factors responsible for such a linguistic complexity.

Algerian Radio Broadcasting Overview

Radio broadcasting is the most popular media in Algeria. Having played an active role in the war of independence, the radio remains one of the most accessible vehicles for communicating information. State-

owned National Radio Broadcasting (Entreprise Nationale de Radiodiffusion Sonore ENRS) manages national radio stations. Similar to the ENTV (Entreprise Nationale de Television) i.e. Algerian Television, the ENRS is expanding and modernizing its network in preparation for eventual sector liberalization and has entered into partnership with France's INA (Institut National de l'Audiovisuel) for training personal, enhancing programming and facilitating the transition to digital radio.

Today, Algeria has three national radio stations: Arabic language channel 1, Berber language channel 2 and French language channel 3. There are also four themed radio stations available nationwide: radio culture, radio Quran, music station El Bahdja, and 24 hour news station Radio International which broadcasts in Arabic, French, English and Spanish. From July 2009, Algeria had 44 local radio stations and by the end of 2009 is set to have 48; a radio station in each province.

After Algeria's independence, a strong unilingual dominance characterized the Algerian media. Modern Standard Arabic; which is the national and official language in Algeria; was at the forefront of state media. It is the case for Arabic language channel 1. As for the other radio stations especially local radios; recently inaugurated in each province in Algeria; the dialect known as Algerian Arabic is the language of communication.

Chachou (2011) affirms that "it was at the beginning of the 2000s that an important change takes place within the linguistic practices due to the economic openness, the development and even the sudden emergence of new technologies (TV satellite and internet)... Excluded for a long time from the media at the expense of institutional Arabic, the native languages make up the ground especially due to some local radio programmes; since they are open to the public, the interactions are broadcasted in these languages" (p.161-163).

The Local Radio of Ain Temouchent (The Case Study)

The local radio of Ain Temouchent is a state-owned station, inaugurated on March 26th, 2008. It broadcasts over its 95.9 FM frequency, as it can be reached by internet and satellite. Its news and programmes are in Arabic language and it covers daily events in many sectors. The local radio serves its listeners by offering a wide variety of content that contains news coverage and different kinds of programmes. The media institution counts thirty one employees among them eight journalists and eleven radio hosts.

The Reality of Language Mixing in the Algerian Radio Broadcasting

Language scholars started to be interested in studying the spoken language with the advent of structural linguistics. However, language variation gained attention with the appearance of sociolinguistics which has for objective to study and investigate the spoken varieties and dialects with the necessary tools already provided to the written form of language. According to Cantone (2007) "language mixing means that a word from language A or an utterance which contains elements from languages A and B is mixed into the language contact of language B" (quoted in Vasquezp.09). Language mixing is often seen by linguists as similar to code switching. The linguistic scholar Grosjean (1982:145) defines code mixing and code switching as the "alternate use of two or more languages in the same utterance or conversation".

Language mixing constitutes a grassroots phenomenon at the Algerian radio broadcasting. Arabic, Tamazight, Spanish, Turkish and French are languages which are related in their context of use in the spoken discourse of Algerian radio broadcasters. The mixture between Arabic and these languages results in a specific and a distinctive code which is adopted and adapted to the Algerian use with new functions and structures. This mixture between Arabic language and other foreign borrowed words may occur between two utterances as it may occur within a single utterance. Accordingly, the shift between the different languages takes place spontaneously and in a natural way in the spoken discourse of radio broadcasters. Consider the following utterances extracted from Ain Temouchent local radio programmes.

Table 3. The mixture between Arabic language and French language

Utterance	Arabic words	French words	Translation to English
/de:ʒa tənəkkaː la sirkulasj ɔn fa saʒf/	/tənəkkaː/ /fa saʒf/	/de:ʒa / /la sirkulas ɔn /	It actually reduces the traffic jam in summer.
/nakadru: nawaslu: zexɔp ka/	/nakadru:/ /nawaslu: /	/zɛxɔp/ /Ka/	We can reach zero case
/lɜ:zəm diru: pɔrt a pɔrt p u: ɣ s ɔnsibilize /	/lɜ:zəm/ /diru: /	/pɔrt a pɔrt / /p u: ɣ/ /s ɔnsibilize /	You have to start door to door sensibilisation

In the above utterances taken from Algerian radio broadcasters' spoken discourse, one may observe a sort of fusion between Arabic and French languages which are mixed together to form a specific code: Algerian Arabic. It is clearly noticeable that French language is playing a more dominant role than the other languages, which results in the impact of French colonialism in Algeria. It is not surprising to hear radio broadcasters switching back and forth between Arabic and French in a single utterance simply because French language is prominent among Algerian speakers and deeply implemented at both formal and informal levels. Considered as a language of modernity, it is to note that French words are also used among broadcasters to designate many technical items. Words such as: transition (transition sound), bande-annonce (preview), indicatif (call sign), habillage (soundtrack), info (news) are largely used. In addition to other English words such as streaming, jingle and briefing. Indeed, the mixture between Arabic and French takes place spontaneously and performed in a natural way.

Table 4. The mixture between Arabic language and other borrowed foreign words

Utterance	Arabic words	Borrowed foreign words	Translation to English
/natʃarfu lju:m ʃla tabak dolma/	/natʃarfu/ / lju:m/ /ʃla/ / tabak/	/dolma/ (Turkish) a Turkish dish	Today we will discover the dolma dish.
/maʃrouf lyarb lɜazajri bel karantika/	/maʃrouf / / lyarb/ /lɜazajri/	/Karantika/ (Spanish) Algerian traditional dish from the Spanish word "caliente"	Western Algeria is known by karantika.
/la plupar de zalɜɛjɔn yhabu: yaklu: ,lbu:ra:k fi ramdan/	/yhabu:/ /yaklu: / /fi / /ramdan/	/La plupar / French /de zalɜɛjɔn/ French bu:ra:k (Turkish)	Most of Algerian people like eating burak in Ramadan

As shown in the above table, other borrowed foreign words are integrated in the verbal repertoire of radio broadcasters including Turkish and Spanish words in addition to French words. Basically, some borrowed foreign words are used in most cases when there are no equivalent words in Arabic language. Radio broadcasters in this case call for the use of foreign words to fill the gap. It seems to be a part of a linguistic behaviour to conform to a more context –appropriate style of speech.

Table 5. The mixture between Modern Standard Arabic and Algerian Arabic

Utterance	MSA	AA	Translation to English
/ba:f ma:jku:nf ʕandhu:m ha:ð lʔirtiba:tʃ lwaθi :q bil ʔaʒhiza ððakijja /	/lʔirtiba:tʃ / / lwaθi :q / /bil ʔaʒhiza / /ððakijja/	/ ba:f / / ma:jku:nf / /ʕandhu:m/ /ha:ð/	To avoid the close connection to smart devices.
/ʕadwa: nʔa:allah jʕa:wad jalqa:kum albarna:maʒ fi: nafsi ʔalmawʕid /	/jalqa:kum/ /albarna:maʒ / / fi:/ /nafsi/ /ʔalmawʕid/	/ʕadwa:/ /nʔa:allah/ /jʕa:wad/	The programme will meet you at the same moment Tomorrow inchallah.
/ħaqi:kat lʔamr annana: ngu:lu: bazza:f swa:lah wa la:kkin ma: ndi:ru:hu:m f/	/ħaqi:kat/ / lʔamr/ /annana:/ /wa la:kkin/ /ma: ndi:ru:hu:m f/	/ngu:lu:/ /bazza:f/ /swa:lah/ /ma: ndi:ru:hu:m f/	Actually, we don't do what we say

The data gathered from the table above indicate a mixture between two varieties of Arabic: Modern Standard Arabic (MSA) referred to as the High variety (H) and Algerian Arabic (AA) referred to as the Low variety (L) (Fergusson 1959). The mix between the two varieties takes place between or within utterances. At the grammatical level, MSA is considered more complex in comparison with AA. The reason for which, some linguistic items are completely deleted or replaced by others from AA. However, one may notice a sort of fusion between the two varieties of Arabic. This connection is resulted in the existence of an intermediary form of Arabic which is known as “the middle variety” or “Educated Spoken Arabic”. The basic features of this variety are predominantly standard, but adapted to the colloquial use.

The emergence of an intermediate form of Arabic

The coexistence between MSA and AA is evolved from a diglossic situation that Algeria denotes. Freeman (1996) argues that “no discussion of Arabic is complete without at least a cursory discussion of diglossia” (p1). It is apparent from table 05 that the combination between the two varieties: MSA and AA gives birth to an intermediate form of Arabic; a new linguistic code, specific to the media use which is codified by radio broadcasters in their daily interactions with the audience to the extent that it can be easily understood by all radio listeners.

A related point to consider is that this mixed code is characterizing almost all radio programmes except for the news which are broadcasted in Modern standard Arabic. Nevertheless, one would stress that during news presentation, some linguistic items are delivered in borrowed foreign words, as already mentioned in table 04 for instance: karantika (Spanish word). Some of these borrowed words are used without any modification such as dolma (Turkish word); others are adapted phonologically and morphologically to the Algerian Arabic use. Some examples of these borrowed foreign words are: ‘sakwila’ from the Spanish word ‘escuela’ (school), ‘tabla’ from the french word ‘table’ (a table), ‘nayer’ from the tamazight word ‘yennayer’ (the first day of the new Amazigh year). Part of the insertions also consists of lexical items referring to Ottoman Turkish lexicography including: ‘cherbet’, ‘tkacher’, ‘nichan’, ‘zerda’, ‘baklawa’, ‘burak’, ‘kahwaji’, ‘telwa’, ‘tbassa’, ‘dolma’, ‘brania’, ‘balak’, ‘kabssa’, ‘derbouka’, ‘rechta’ (Bou Cheneb 2012). It is worth to highlight here that the Turkish elements that occur in Algerian Arabic are generally nouns, other constituent types are embedded with low frequency.

Reasons for Language Mixing in the Algerian Radio Broadcasting

Algerian Arabic which relies largely on mixing many languages is used by Algerian broadcasters for many reasons:

- To address not only the educated people but all Algerians who remarkably differ in their educational and cultural backgrounds.
- To fit situational, social, cultural and relational context.
- To tone down the complexity of the literary standard Arabic.
- To accord radio broadcasters the possibility of being close to the audience, far away from formality and distance.

Algerian Arabic: a distinctive code for an effective communication

Many studies undertaken to investigate language contact phenomenon indicate that code mixing/switching is a strategy of communication. For Gumperz (1970) “code switching is meaningful in much the same way that lexical choice is meaningful. It is a verbal strategy used in much the same way that a skillful writer might switch styles in a short story” (p152).

In this sense, Vasquez (2012) indicates that “Language mixing does not only relate to a momentary linguistic need; it is also very useful communication recourse. It takes place unconsciously; speakers are often relatively unaware that they are switching from one language to another. The main concern is transmitting a message or a purpose and they know that the other person will understand them whether they use one or two languages when transmitting the message”. She adds:” very often a bilingual knows a word in both language X and Y, but the language Y word is more readily available at that moment when speaking language X” (p 09-10).

Algerian Arabic which is the mother tongue of the Algerian society is gradually integrating the Algerian media. It becomes now the communication medium of the majority of radio broadcasting stations especially local radios which are more close to the local community. Badawi(2006) highlights the fact that “whereas the ‘Quranic’ variety of Arabic was previously the model of Standard Spoken Arabic, the language of the media is becoming the model for present-day educated and non-educated native Arabic speakers”.

On the basis that media language should be understandable by the wide range of audience, Algerian Arabic which relies largely on mixing many languages represents the specific code used by Algerian broadcasts to address not only the elite but all Algerian people who remarkably differ in their educational and cultural backgrounds. This Algerian distinctive code constitutes a specific linguistic style employed for a specific goal: an effective communication.

In addition to increase understanding, radio broadcasts adopt this communicative attitude to fit situational, social, cultural and relational context. It means that radio broadcasters aim at being close to the people since the radio is beyond any doubt the citizens’ voice. For such a reason, radio broadcasts perform multiple aspects of their socio-cultural identities. Fishman states that “the appropriate designation and definition of domains of language behavior obviously calls for considerable insights into the socio-cultural dynamics of particular multilingual settings at particular periods in their history” (p92).

One point worth noting is that this specific Algerian Arabic used by radio broadcasts is considered as an appropriate and suitable code which avoids rudeness and discourteousness .It is called by some linguists “the middle variety”. Al Toma (1969) assumes that “Speakers mainly educated ones may switch for a shorter or longer period of time to the high variety, or they mix the two varieties in the same conversation. This kind of speech is the middle variety” (p05).In the media field, this distinctive code is known as Educated Spoken Arabic and which is supposed to lessen the linguistic tension between the educated and non educated Arabic speakers. In this regard Ferguson (1959) explains that ESA is “a kind of Spoken Arabic much used in semi-formal and cross-dialectal situations which has highly classical vocabulary with few or no inflectional endings, with certain features of classical syntax, but with a fundamentally colloquial base in morphology and syntax, and a generous admixture of colloquial vocabulary” (p433) .Relying on Modern Standard Arabic, colloquial Arabic and foreign languages, ESA has the capacity of being understood by educated and non educated people. Bouhadiba (1998) notices that “the amalgamation of the different varieties in place gives birth to an intermedial level of Arabic: “al Lughal Wusta” or intermediate Arabic.

Recommendations

Language mixing in the media field is largely criticized by some defenders of Arabic language on the basis that this linguistic behaviour could represent a real threat for Arabic in an age of worldwide globalization and rapidly spreading communication technology. In contrast to this idea, one may call for a better appreciation of language mixing at the Algerian radio broadcasting for the reason that within this language contact and combination that Arabic language can stay up-to date and open to the world. Taking into consideration the linguistic diversity of the Algerian verbal repertoire, Algerian Arabic; which constitutes the result of this language mixing phenomenon remains an important variety which plays a great role for an effective communication. Thus, it is highly recommended to maintain and preserve this distinctive code in such a professional milieu since it reflects the Algerian history, culture and identity. It would also be interesting for further researches to experiment written texts in other types of media especially social media texts which have added new dimensions to language evolution. It is to note accordingly, the growing tendency to find lexical and structural elements from Algerian Arabic in informal writing such as private correspondences. Haugen (1970) argues "language can be best understood in its social context. This social context determines which forms of speech are more appropriate than others" (p57).

Conclusion

The linguistic diversity instigates frequent language mixing in Algeria. Due to historical events and socio-cultural changes the country has passed through, Algerians are multilingual by necessity; they frequently mix different languages in their daily interactions. Since the radio broadcasting is actually a mirror of the society and by the fact that radio programmes are related to the social domain and therefore to the informal frame, mixing languages occurs among radio broadcasters as a natural and inevitable consequence of multilingualism that Algeria witnesses. Giving birth to a specific code called Algerian Arabic; which has its own structures and rules, mixing languages in the spoken discourse of the Algerian radio broadcasters is adopted as a strategy of communication to deliver a simple and clear message to the large audience from different socio-cultural backgrounds. It represents consequently the adequate means for an effective communication.

List of Acronyms

CA : Classical Arabic

MSA : Modern Standard Arabic

AA : Algerian Arabic

ESA : Educated Spoken Arabic

References

- Al-Toma, S. J. (1969). *The problem of Diglossia in Arabic: a Comparative Study of Classical Arabic and Iraqi Arabic*. Harvard:Harvard University Press.
- Badawi, E. S. (2006). *Arabic for non- native speakers in the 21st Century. Handbook for Arabic Language Teaching Professionals in the 21st Century*. Mahwan, New Jersey. Lawrence Erlbaum Associates Publishers.
- Bagui, H. (2014). *Aspects of Diglossic Code switching Situations: a Sociolinguistic Interpretation*, 2(2), 86-92.
- Bencheneb, M. (2012). *Mots turcs et persans conservés dans le parler Algérien*. Publication du cinquantenaire de l'Université d'Alger. Thèse complémentaire en vue du Doctorat Es Lettres.
- Bishai, W. B. (1996). *Modern Inter Arabic*. *Journal of American Oriental Sociology*. 86(3), 319-323.
- Bouhadiba, F. (1998). *Continuum Linguistique ou Alternance de Code? Essai d'analyse dynamique des faits. (États de lieu)*. Cahier de linguistique et de didactique. Vol(1), ILE, Oran.
- Cantone, K, F. (2007). *Code-switching in Bilingual Children*. Volume37. Springer Science and Business Media.
- Chachou, I. (2011). *Aspects des Contacts des Langues en Contexte Publicitaire Algérien. Analyse et enquête sociolinguistique*. HAL. Thèse de doctorat de science du langage. Ecole doctorale de Français. Mostaganem. Algérie.
- Fatmi, M. F. (2017). *The diglossic situation in an Algerian Language Teaching Context*. PhD Thesis. University of Tlemcen, Algeria.
- Ferguson, C.A. (1959). *Diglossia*. *WORD*, 15(2), 325-340.
- Fishman, J.A. (1965). *Who Speaks What Language to Whom and When*. *La linguistique*, Vol.2, 7-88

- Freeman, A. (1996). Perspectives on Arabic diglossia. <http://www.personal.umich.edu/andyf/hisArab.html> (accessed March 21,2014).
- Grosjean, F. (1982). Life with two languages: an introduction to bilingualism. Cambridge, Mass: Harvard University Press.
- Gumperz, J. (1970). Verbal Strategies and Multilingual Communication. Edited by James E,A. Washington,DC: Georgetown University Press.
- Haugen, E. (1970). Linguistics and Dialinguistics. Georgetown University Monograph Series in Languages and Linguistics 23, 1-80.
- Kerma, M . (2018). The Linguistic Friction in Algeria. Sociology International Journal. Volume 2 Issue 2.
- Vasquez, M. (2012). Syntactic Aspect of Code switching in Bilingual Spanish-Swedish Children. Linnaeus University.

Author Information

Horiya Amar Bekada

University of Oran 2.Algeria
B.P 1015 El M'naouer 31000 Oran, Algeria
www.univ-oran2.dz 213 661842525
Contact E-mail :horiaamarbekada@gmail.com

Soraya Hamane

University of Oran 2.Algeria
B.P 1015 El M'naouer 31000 Oran, Algeria
www.univ-oran2.dz
213791951750

Art in Industrialization Process: Change and Transformations in Art after 20th Century

Mehmet SUSUZ

University of Necmettin Erbakan

Mahmut Sami OZTURK

University of Necmettin Erbakan

Abstract: The phenomenon of art has experienced many changes and transformations along with humanity. It can be said that important breaks in art occurred after World Wars. Especially, the beginning of the 20th century were the years which the foundations of the transformations in art were laid. The inclusion of ready-made objects, which are a part of daily life and produced as industrial products, into the art process as art objects started with Duchamp and supported the formation processes of the movements of art that emerged after 1950. These movements of art which have highlighted the notion of 'concept' in art and have been fed by 'socio-cultural' phenomena that emerged as a result of world wars. The industrialization movements, which especially had an impact on the USA and European countries, have shown their effect in many areas of life. The phenomenon of art has taken its share from the mobility of the industry. This situation virtually has prepared the ground for the emergence of 'struggle for existence' process of industrial products in the field of art. It can be said that, as the perceiver of art, the audiences have difficulty in interpreting the art that's been restructured with the involvement of industrial products. In this study, it is aimed to mention "the use ready-made objects reproduced by mass production technique as an art object in the process of industrialization" and to identify "the changes and transformations experienced in art in this process".

Keywords: Art, Contemporary art, Industry, Ready-made objects

Introduction

The phenomenon art has been shaped in different ways on the axis of socio-cultural motivations in every period. Following the developments in industry in the 18th and 19th centuries, the intensive development of mass media after world wars and the logic of mass production of the industry have influenced the transformation process of the form and content of art.

Considering that the movements of modern art came to the forefront after 1850, it is possible to relate this art to the social processes arising from the industrial revolution. As each artist is shaping his work, he is fed to a certain extent by the society's life or by the processes which he obtains from his interaction with life (Şaylan, 2009: 88-89). "The scientific developments in the 20th century have also affected art... In the last quarter of the 19th century and in the 20th century, technological development has influenced artistic creation in different plans and dimensions and has led to the emergence of new sense of aesthetics" (Tezcan, 2011: 122-123). With World War II, the terrible consequences of scientific developments have been encountered. The tools produced as a result of scientific advances have caused effective destruction and deaths. After the war period, there have been developments in the industry (Anderson, 2011: 123-124). After the wars, several strategies have been developed within the context of consumption/ production in the industrial area in America and Europe. Industrial products serially produced have been offered to the consumption of the society. In the 1910s, ready-made objects were included in the art without any commercial purposes. After the 1950s, Pop-Art nourished by the images of popular culture presented by the industry to society has assumed its mission as an advertising medium. These processes, in which industrial products were added to the art, have made a strong impression on the artistic products after 1980.

- This is an Open Access article distributed under the terms of the Creative Commons Attribution-Noncommercial 4.0 Unported License, permitting all non-commercial use, distribution, and reproduction in any medium, provided the original work is properly cited.

- Selection and peer-review under responsibility of the Organizing Committee of the Conference

In this study, the use of objects produced by the industry with the logic of mass production as an art object is being discussed. In the 20th century, radical steps have been taken on behalf of the art. In this period, the 'efforts to evaluate the ready-made objects produced by the industry in the status of art objects', which reacted to the modern art, have started the process of discussing the known forms of the art. We can name Marcel Duchamp as one of the most important architects of this process. In order to understand the reasons of this change and transformation in art, it is necessary to mention the socio-cultural structure of that period. The environment of free thought, which started with the age of enlightenment, has made significant contributions to the sense of modern art. The situation that emerged with the world wars in the 20th century has made the concept of modernism debatable.

In postmodernism, which is expressed as the radical critique of modernism, "... it is the matter of denegation of modernism in its totality not to rebuild it through criticism" (Şaylan, 2009: 141). Postmodernism takes a stand against modernism and enlightenment movement. The starting point of modernism is the age of enlightenment (Bozkurt, 2014: 80). Postmodernism, which is a reaction against modernism, has made indelible impression in many disciplines. Postmodernism, on the one hand, nurtured by the elements of modernism and on the other hand, showed a critical approach to modernism, has criticized the familiar structure of the art. Especially with the anti-art movements that started in the 1910s, it has been gone beyond the familiar codes of the art. In this process, the objects manufactured by the industry with the logic of mass production have been come into use as art objects. At this point, it is necessary to mention the relationship between 'art and industry object'.

Art and Industrial Object Relation

Industry means "the processing of raw materials in a certain field or occupation through mass production, using them and the creation of new goods through release, and providing the amount of goods as well as the wealth of purchasing power" (Erinç, 2004: 69-70). At first glance, the combination of heterogeneous concepts such as industry and art can be considered strange. Because the system running of art and industry are different from each other. When it comes to industry, the logic of mass production comes to mind in the mechanized world. When art is mentioned, the works produced on the axis of aesthetics and originality, whose uniqueness is preserved by the artist, come to the mind. At this point, the factors that bring the concepts of art and industry from heterogeneous structure to homogeneous structure become more of an issue.

The artist reflects the traces of the socio-cultural life of the society in which he lives to his works. Although this expression reveals the interaction of the artist, artwork and society, until the 20th century, the domination of the elite on art was a matter. The art movements that emerged after the 20th century aimed to convey the art to the lower layers of society by eliminating the influence of the elite on art. Object-art interaction coincides with the beginning of this process. The interaction between the ready-made object and art took place in the 1910s. The artistic motivations that emerged in this process has ignited the changes and transformations of art after 1950. In this process, it can be said that Marcel Duchamp has actualized the interaction between art and daily life by carrying objects used in daily life to the field of art.

In the process of interaction of industrial products with art, there are periodic differences in terms of artist and sense of art. Duchamp's inclusion of ready-made objects in art has critical value about the state of modern and pre-art. Pop-Art, which emerged after 1950, took a stand in support of consumption culture in a way by using popular images produced serially by the industry. Most of the art approaches that emerged after the 1960s show a critical approach to the consumption culture in which the consumption objects produced by the industry are used as art objects in the art works. Although artworks were produced for different reasons in this process, a relationship was established between the used industrial products and art.

Consumption Culture

In the second half of the 20th century, the industrial mobility of societies that tried to get rid of the destructive effects of wars has made its impact in the field of art. The logic of mass production has activated the phenomenon of consumption along with itself. The production strategies under the guidance of the capitalist system have prepared the ground for the emergence of the concept of 'consumption culture' by taking the concept of 'consumption' out of the familiar meaning. In this study, which is based on the relationship between industry and art, 'the use of objects produced serially by the industry as art objects' has been discussed. However, it is necessary to mention the concept of 'consumption culture' which is one of the socio-cultural processes that cause the use of mass-produced industrial products as art objects.

“... Fordism should not be addressed only as a system of mass production, but rather as a holistic way of life. Mass production meant standardization of the product as well as mass consumption; this meant a totally new aesthetic and commodification in culture...” (Harvey, 2014: 158). The ‘society engineers’ build the capitalist system. Society engineers determine the production strategies in the context of the supply and demand relationship of the society. Consumption makes its presence felt at all levels of the society. The system, while carrying out the production process for all levels of society, at the same time directs the society to consumption objects with the help of mass media to consume the industrial products produced. Although some of the objects produced by the industry (such as television, car, etc.) appeal to the elite layer in the first stage, the same objects produced serially in time reach to the lower layers of the society as well, and become standard. A system that constantly produces makes out a society that consumes continuously. Consumption has now gone beyond the usual meaning and has reached the point of ‘the objects consumed as if it were necessary but not essential for the survival of the individual or society’. According to Akay, the state of capitalism and consumption society, and the social response, heralded the attainment of new formations in art. New Realism, Pop Art, Situationism, Happenings, Fluxus, Sinetic Art, Arte Povera, New Figuration, which developed one after another, all followed each other in the name of pioneering” (Akay, 2002: 162). ‘Excessive consumerism’, in which the society is involved, emerges as an issue that artists nurture while creating their works. While some artists have glorified the consumption culture by using popular images in their works, some artists have critically approached the problem of consumption culture in society. Especially in most of the post-1960 movements of art, artists have shaped their works by reacting to the purchase and sale of works of art as a commodity in the consumption culture process. Artists have used many industrial products as art objects in creating their works.

Findings and Discussion

Art in Industrialization Process

“It is one of the main features of postmodernism in art that the formal norms and formal methods followed are subject to a wide variety.” (Sarup, 2017: 242). “Human beings began to adopt the punctuality and mathematical infallibility brought by machines and machine parts, and not the unique, non-repeating free hand of the artist, on the exterior of the objects.” (Kagan, 2008: 493). Industry-Art interaction has eliminated the uniqueness of art. It is seen that similar industrial products are used as art objects. The works given below are reproduced by the same artists at different times and presented to the art audience.

The American art philosopher George Dickie sets out two basic criteria for calling industrial ready-made objects 'art':

- 1- “An object or application must have been altered by human intervention.
- 2- An object or application should be exhibited or presented in a gallery and in the context of the art world” (Whitham and Pooke, 2013: 6).

It is necessary to mention Duchamp's work on the basis of two main criteria of George Dickie. In the work called 'Bicycle Wheel' (1913), the objects used were modified by artist intervention and made into different forms. Objects used in different fields were combined and incorporated into a new process. That work of Duchamp is an example to Dickie's first criteria. Duchamp created his work 'Bicycle Wheel' by removing the mechanism of the front wheel of a bicycle and turning it over and placing it on a four-legged stool. Looking at the work, it is seen that a different form emerges from the combination of ready-made objects produced for different purposes. Both objects are free from functions assigned to them for their production purposes. The artist has now given these objects new and different functions. Although it may seem like a work that does not require skill, this work is at the center of the fundamental changes in the art in terms of the intellectual processes that the artist wants to put forward. Therefore, it can be said that this study has a philosophical feeling.

Duchamp's 'Fountain' (1917) can be shown as an example to Dickie's second criteria. In this work, the artist presents the urinal object, which is a part of daily life, to the audience by reversing the posture direction. The urinal was freed from its purpose of manufacture and only its direction was changed without any intervention (except for the signature of the artist). In this work, it can be said that the artist showed a critical approach to the concept of aesthetics. The object remained with no function and commercial value given to it for its purpose of production. Duchamp's inclusion of industrial objects in art influenced Pop-Art, which emerged in the 1950s, and many other art approaches later on.

In pop art, "They used stereotyped images, thinking that they could really get into life with the use of mass media (...) The term pop, which arises out of these thoughts, was later used to complement the painting

movement.” (Kale, 2002: 43). The 1950s were the years when the advances in technology progressed rapidly. The diversification and effective use of mass media has also affected art. As a part of the capitalist system, the industry has sought many new ways of delivering the mass-produced objects of consumption to the recipient (society). In addition to the potential of mass media, industry has included art, a "communication language", to the system. Pop-Art supported this process by using popular images produced by the industry. Although it has been suggested that art is a part of daily life and that industrial objects used in daily life can be objects of art, many researchers state that Pop-Art is an 'advertising tool' in the process of introducing industrial products to society. It can be said that pop-art acts as a communication between product and society in the process of presenting industrial images to the society by effectively using the 'advertising' phenomenon of the capitalist system. Advertising endeavour to send messages to consumers with the codes and cyphers that are created by feeding from the cultural memories of societies. In a way, it uses cultural textures that will correspond in the society.

"According to Warhol, art is commercial, which gives us clues to the power of commerce rather than the power of art." (Kuspit, 2014: 163). "In order to understand how art developed in the age of capitalism, it is necessary to look at the place of art in the system of social production and exchange. Capitalism has made commodity production the universal and all-inclusive form of economic life in society." (Kagan, 2008: 488). Art continues its existence by feeding on the socio-cultural processes of the society in which it is presented. Just as artists have used religious themes in their works during the times of religious authority, in the societies where different changes and transformations took place, artists inspired from the social dynamics and shaped their art.

Andy Warhol's 'Brillo Boxes' (1964) is one of the most important examples in terms of the relationship between industry and art. The artist took Brillo branded dishwashing sponge boxes produced by the industry in series and stacked them on top of each other similar to the images in the warehouses of the markets and presented them to the audience as a work of art in the exhibition hall. The artist named his work 'Brillo Box' statue. This work is 'whether or not a work of art' has been discussed by art critics. In particular, the evaluations of US art critic Arthur Danto have great importance. Stating that despite many who say that Warhol's work is not art, he is convinced that it is art, Danto seeks the answer to this question; "While he was unable to explain the difference between Warhol's Brillo Box statues and the supermarket store's Brillo boxes, it was where the difference lies between the two." Danto stated that Warhol's work and work of art can be produced outside the usual and known patterns, and even the industrial products that are a part of daily life can be objects of art or resemble these (Brillo boxes or soup cans) objects. (Danto, 2014: 60). For Warhol's Brillo Boxes, Danto says, "If industrial objects used in daily life are used as art objects and the difference between them cannot be discerned, it shows that "...art becomes indescribable by visual difference..." and therefore argues that "...art must be characterized philosophically" (Stallabrass, 2013: 146). Especially in the 20th century, art works other than the familiar artistic forms were produced. After 1960, rather than form, the content of art came to the forefront. This necessitated a philosophical examination of the conceptual dimension of the works of art.

Jeff Koons produced works about consumption culture whose influence was felt intensely after 1950. The works created by various vacuum cleaner models that are industrial products are among the works that reveal the change and transformation that art has gone through in this process. His work 'New Hoover Convertibles, New Shelton Wet / Drys 5-Gallon Doubledecker' (1981-1987) is important in this context. This work of Koons consists of two rectangular compartments. (The upper compartment is approximately half the size of the lower compartment.) In the larger bottom compartment, three bagged vacuum cleaners of same brand and model are mounted by their handles and aligned side by side. In the upper compartment two vacuum cleaner machines of the same brand and model with hose in the dust bag are arranged side by side in the same position. Both compartments were illuminated by fluorescents placed under the broom machines.

Jeff Koons puts the vacuum cleaners "...in an epic position by placing the vacuum cleaner in an elegant plexiglass showcase like a sacred space with fluorescent display lights. For Koons, it is both an aesthetic object (...) and a social icon." (Fineberg, 2014: 458). In this work, "...an object purchased from a shop and not shaped by an artist is given art status. This increased the cultural and financial value of the object in question." (Whitham and Pooke, 2013: 57). In this work, the artist presented the industrial vacuum machines to the audience as an art object. As Whitham and Pooke put it, the vacuum cleaners produced for dust and dirt cleaning purposes were upgraded to the status of art objects, and displayed on a stage. At that point, a similar situation is encountered to Danto looking for an answer to the question "Where does the difference lie, while the difference between Warhol's Brillo Box statues and Brillo boxes arranged in a supermarket warehouse is indiscernible?", regarding Warhol's Brillo Boxes works. Especially in Koons' works, traces of Warhol's understanding of art can be seen.

Warhol and Koons have ripped the objects they used in their works from the plane of reality, and placed them on the simulation axis. Baudrillard stated "Simulation as a false form of revitalization..." (Baudrillard, 2014: 1). "Koons takes an ordinary object in the consumer markets and renders it hyperreal in a glass bell" (Şahiner, 2008: 115). What is called 'reality' is the function that the industry gives to the vacuum cleaners that it produces in series for daily use. For the purpose of manufacture, the concept of 'reality' can be mentioned as long as the function given to the vacuum cleaners exists. However, if the artist purifies these objects from the functions assigned to them in their production, these objects will be separated from the axis of 'reality', and will regain identity with different codes in the context of the artist's thoughts and idea. Although there is no difference in the formal sense, those objects are now separated from the purpose of production.

"Differences in the aesthetic understanding of people create the concept of art, and it changes in the concept of art create, and has to create, different aesthetics" (Erinç, 2013: 158). "The aesthetic criterion that is valid for the new concept of art characterized by the word 'postmodern' is also called the aesthetics of the body." In the postmodern process, artistic objects must activate the viewer's emotions and leave them under effect. The aesthetic criterion here is the instant and temporary arousal and excitement. Warhol interpreted the objects used in the daily life of the society and reflected them to his art. He mimics common and familiar objects. (Şaylan, 2009: 118-119). The viewer who sees Koons's vacuum cleaner machines can associate it with the vacuum cleaner he uses as part of his daily life at home. With the freedom to choose and buy from the dozens of the same brands and models in the store for a certain price, the art viewer has taken the vacuum cleaners beyond the reality with the *magical, hard-to-reach* label that Koons has installed on the vacuum cleaners. In this work, the artist has given a new identity to the vacuum cleaners. Koons has increased the value of the industrial vacuum cleaner, which is easily available to everyone for a certain price. The vacuum cleaner, which can easily be purchased by the lower class, is now offered to the elite as an art object at high prices by Koons. Although the idea of saving art from the monopoly of the elite to the lower class of society is among the aims of post-1950 art conception, there is the opposite situation in Koons' work. Similarly, there is a similar situation in the sale of Warhol's works at high prices. Both Koons and Warhol removed the boundaries between art and life, using industrial products as part of daily life as an art object. However, the selling of works with high prices can be shown as an example of the commodification of art.

Industrial products were used in the works produced in the fields of painting, photography, sculpture, installation, etc. German photographer Andreas Gursky has reflected many subjects that touch the social life to his work. An example of this is the work of '99 Cent ', one of his large-scale works reflecting the consumption culture of society. "...Andreas Gursky's '99 cent' (1999) is a photograph of a store of 3.37 meters" (Whitham and Pooke, 2013: 250). Gursky, photographing hundreds and maybe thousands of industrial products, neatly arranged on the shelves of supermarkets, reflects the image of the capitalist system back to us. In this work, the shelves that create colour harmony with their packages of different colours are photographed in wide angle. Customers walking between shelves emphasize the continuity of the consumption process. The phrase (99) on the price tags next to the products in supermarkets can be perceived as a criticism on the unicity in pricing, and therefore on the consumption society, which capitalism is trying to standardise.

Sylvie Fleury's work created using industrial products is reminiscent of a shop window. In his work, as in Warhol and Koons' work, traces of the sociology of consumer-age society can be found. Some of Fleury's works have criticizes the consumption society. Like Duchamp, Warhol and Koons, Fleury does not interfere with the industrial products he uses in his work. However, in some of his works he made different arrangements by bringing together different objects. On the basis of Fleury's work traces of concepts such as industry, consumption, popular culture, fashion, capitalism are seen.

Art became increasingly commodified by capitalism. In the process of economic mobility, similarities emerged between the works of art and the consumer goods. These similarities "Depend on the rhythm of the economic cycle...". This situation of the economy fed the art applications after 1990. "Sylvie Fleury spread the goods she bought from high society boutiques on the gallery floor; or placed acclaimed, latest fashionable products ... on pedestals" (Stallabrass, 2013: 77). The artist placed high-end fashionable products purchased at high prices appealing to the elite class on sculpture pedestals made of wood. It can be said that this work of the artist is a criticism on consumption culture. Fleury mounted target boards with numbers on the top of two parallel pulleys. The trendy bags of different colours are hung on the wooden pulleys. When the work is looked at, both the target boards and the bags have marks similar to bullet holes. Perhaps the artist used wooden pedestals as a representation of consumer individuals in this work. The marks on the target board can be said to indicate that society is the target of capitalism. This work can be given as an example of the effect of popular culture fed by the concepts of 'luxury' and 'fashion' on consumption society.

According to Adorno, "...consumers feel that the amount of product given to them decreases as the price of a product falls" (Adorno, 2014: 99). In the light of these expressions, the concepts of 'luxury' and 'fashion' in society suggest 'expensive products'. If the capitalist system wants to put a product into the 'expensive product' category, it can do so by using many arguments. In our day, one of the factors determining the society's tendency to consumption can be said to be due to the success of the capitalist system in making good use of the arguments to manipulate the perception of society. Many industrial products (cars, home appliances, mobile phones, accessories, dresses, etc.) are actively consumed, although they are offered to consumers at high prices. The perception of a low-price product in the society can be perceived as 'poor quality, inadequate, nondurable'. The idea that the quality of a product is directly proportional to the price of that product is part of the structure of the capitalist system.

Some artists have used the same industrial product in their work in different ways. For example, the 'shopping cart' used in the supermarket is handled in the context of consumption culture and used in different concepts. In some works, only 'shopping cart' constitutes the whole work of art, while in some other works it is used in conjunction with various objects. In this respect, Sylvie Fleury's 'ELA 75/K' (2000) and Duane Hanson's 'Supermarket Lady' (1969-1970) can be cited as examples.

In her work 'ELA 75/K', Sylvie Fleury, "...has combined the simplest and most useful with pretentious consumption by gilding shopping carts in the supermarket to examine the different levels of consumer activity." (Stallabrass, 2013: 77). When we see the shopping carts; meanings such as supermarket, consumer objects, shopping, vehicles (means/tools used to transport consumer goods from the shelves to the payment point), etc. come to our mind. Similarities can be found between this work and Yves Klein's 'Le Vide' (1958), that she used and presented the art gallery Iris Clert as the art object itself. Klein's idea that galleries and exhibition halls, which are used as a tool in the process of presenting artworks to the viewer in traditional art, can be purely an object of art bears a resemblance to Fleury using hollow polished shopping carts as pure art objects.

The American artist Duane Hanson's 'Supermarket Lady' (1969-1970) shows an overweight woman and a shopping cart whose interior and bottom shelf are completely filled with consumer objects. In the work, not only the shopping cart, but also the objects of consumption and women formed the work as a whole. A human-sized female sculpture by Hanson in a hyper-realist style reflects the codes of the consumption process in which that society lives. In her work, industrial products have been placed in a shopping cart in such a way as to there is no empty space. Even the bottom shelf of the car has been filled. Consumption culture, which is a product of the capitalist system, tries to provide the interaction between the individual and the product by making the individual perceive all consumption objects as needed. The individual who walks by the supermarket aisles with the shopping cart puts the different products that he cut into his eye into the products to be consumed and puts them in the shopping cart. After a certain period of time, the individual notices that the shopping cart is full and ends the shopping. Perhaps in this work, the artist may have wanted to emphasize the small size of the car as one of the factors that ended the 'consumption' activity. In both Fleury's and Hanson's works, the industrial shopping cart has been used as a common object. In both studies, we see similarities in the messages intended to be given in the context of the 'consumption' phenomenon.

Mexican artist Gabriel Orozco has made various studies using bicycles which are products of the industry. Orozco's work named 'Four Bicycles (There Is Always One Direction)' (1994) has displaced our cycling ability with conceptual thinking in a short time. Just like the bicycle wheel Duchamp fixed on the stool, which is one of his ready-mades. The greatest power for the artist is a conceptual proposition. Orozco's bicycles allow us to reflect the distance between ordinary and extraordinary, how we are automatically prepared to understand something, and allow us to re-conceptualize and reuse new experiences that do not need to seem rational. Contemporary art regularly transforms concrete concepts into abstract concepts and creates abstract relations by encouraging them to question the normal situations associated to concrete concepts (Minissale, 2013: 51-57). The work that the artist has articulated with industrial objects reminds of a mobility or a vital cycle. The artist, as in Duchamp's 'Bicycle Wheel' (1913), has tried to give them the status of art object by destroying the function charged to objects for the purpose of production.

The use of industrial products as an art object is seen extensively in the post-1960 movements of art. Happening artist Allan Kaprow filled the car tires which are products of the industry into a place in his work named 'Yard' (1967) in which he has aimed to combine art with daily life. Audiences invited to the show become a part of the art while performing their natural activities (walking, sitting, etc.) over the tires. High-tech components provided by the industry have been incorporated into the art. In Nam June Paik's performance work 'TV Cello' (1971), he transformed three television sets of different sizes into a violoncello which is a musical instrument by

placing them on top of each other. Like these artists, many artists have used industrial products in the artworks they have formed.

Conclusion

Art has a dynamic structure that extends its scope by feeding from many different textures. With the 20th century, changes in the familiar structure of art in terms of 'form and content' began to be seen. Marcel Duchamp's inclusion of ready-made objects in the 1910s can be regarded as the starting point for changes and transformations in post-1950 art. The artist is fed from socio-cultural processes while creating his work. The work of art is like a mirror reflecting a society. Therefore, wars, migrations, economic problems, unemployment, human rights, scarcity, capitalism, globalization, industry (industrialization), technology, consumption, and such situations have the potential to affect the structure of art.

“Industrialization has created and disrupted traditional patterns by creating a wide variety of biased lifestyles. (...) In this period, the artists have felt the need to question the harmony and stylistic rules of traditional forms which were thought to be unique in art ... until that day and to investigate the inner logic, origin, meaning and function of art in parallel with scientific logic ” (Ulusoy, 2005:153-154). Industrialization increases the living standards of the society. This situation makes it inevitable to go beyond traditional forms in many areas of life. The phenomenon of art is also affected by the changes in the society as a result of industrialization. In addition to the production of serial works of art with technological arguments, the process of creating works of art using the objects produced by the industry also emerges. This situation has brought forms that are not similar to the known artistic productions and have undergone formal changes and transformations. As Ulusoy has stated, it has brought forth "... the need to explore the inner logic, origin, meaning and function of art. Especially in the movements of art that emerged after the 1960s, the discourse that 'the content (the message that is intended to be given) is more important than the form of art' has revealed the necessity of examining the conceptual aspects of the works of art produced in this process.

In the study titled 'Art in the Process of Industrialization: Change and Transformation in Art after the 20th Century', it has been tried to reveal how the mobility in the industry was reflected to art with the 20th century. In this study, examples of the works of different artists have been given. In all of the examples, 'industrial products produced by mass production method' have been used. The artists have exhibited different perspectives in their works which they formed using industrial products. Duchamp's works he has used ready-made objects are a reaction to traditional art. In his work, Warhol undertakes a mission that glorifies the products of the industry and introduces them to society by using popular images produced by the industry. Koons, on the other hand, detaches the objects produced by the industry, which are part of the daily life, from the context of reality. Fleury and Hanson refer to the consumption society with industrial objects in their work. Kaprow allows the viewers to experience daily life in his work he has formed using industrial products.

The use of industrial products as an art object emphasizes the relationship between art and life. In a way, it shows that the boundaries between art and life have been removed. Art viewers, who are accustomed to traditional art forms, may have difficulty in perceiving these kinds of works they are not used to. The question of how objects produced by the industry, which are part of the daily life, can be an object of art can be answered by Danto's words: "... by characterizing the works philosophically..." Danto also emphasizes that every artwork produced should be evaluated according to the conditions of the period in which it was produced. Considering that art is a phenomenon fed by socio-cultural motivations of society, it can be said that it is inevitable for art to undergo change and transformation in terms of form and content in every period.

References

- Adorno, T. W. (2014). *Kültür Endüstrisi Kültür Yönetimi*. Sunuş: J. M. Bernstein, Dizi Editörü ve Derleyen: Ali Artun. Çev. Nihat Ülner-Mustafa Tüzel-Elçin Gen. İletişim Yayınları: İstanbul. 9. Baskı.
- Akay, A. (2002). *Kapitalizm ve Pop Kültür*. Bağlam Yayıncılık: İstanbul. 1. Baskı.
- Anderson P. (2011). *Postmodernitenin Kökenleri*. Çev. Elçin Gen. İletişim Yayınları: İstanbul. 5. Baskı.
- Baudrillard, J. (2014). *Simulakrlar ve Simülasyon*. Çev. Oğuz Adanır. Doğu Batı Yayınları: Ankara. 9. Baskı.
- Bozkurt, N. (2014). *Sanat ve Estetik Kuramları*. Sentez Yayıncılık: Ankara. 11. Baskı.
- Danto, A. C. (2014). *Sanatın Sonundan Sonra-Çağdaş Sanat ve Tarihin Sınır Çizgisi*. Çev. Zeynep Demirsü. Ayrintı Yayınları: İstanbul. 2. Baskı.
- Erinç, S. M. (2004). *Kültür Sanat Sanat Kültür*. Ütopya Yayınevi: Ankara. 2. Baskı.

- Erinç, S. M. (2013). *Sanatın Boyutları*. Ütopya Yayınevi: Ankara. 3. Baskı.
- Fineberg, J. (2014). 1940'tan Günümüze Sanat-Varlık Stratejileri. Çev. Simber Atay-Eskier (Bölüm 1, 2, 3, 4) ve Göral Erinç Yılmaz (Bölüm 5, 6, 7, 8, 9, 10, 11, 12, 13, 14, 15, 16). *Karakalem Kitabevi Yayınları*: İzmir.
- Harvey, D. (2014). *Postmodernliğin Durumu-Kültürel Değişimin Kökenleri*. Çev. Sungur Savran. *Metis Yayınları*: İstanbul. 7. Baskı.
- Kagan, S. M. (2008). *Estetik ve Sanat Notları*. Çev. Aziz Çalışlar. *Karakalem Kitabevi*: İzmir. 1. Baskı.
- Kale, N. (2002). *Modernizmden Postmodernist Söylemlere Doğru*. Doğu Batı Yayınları: Ankara. *Doğu Batı Düşünce Dergisi*. Yıl: 6. Sayı: 19. Mayıs-Haziran-Temmuz-2002. ISSN:1303-7242. s.s. 31-51. 3. Baskı. (2011).
- Kuspit, D. (2014). *Sanatın Sonu*. Çev. Yasemin Tezgiden. *Metis Yayınları*: İstanbul. 4. Baskı.
- Minissale, G. (2013). *The Psychology of Contemporary Art*. Cambridge University Press: New York.
- Sarup, M. (2017). *Post-Yapısalcılık ve Postmodernizm-Eleştirel Bir Giriş*. Çev. Abdülbaki Güçlü. *Pharmakon Yayınevi*: Ankara. 5. Baskı.
- Stallabrass, J. (2013). *Sanat A.Ş. Çağdaş Sanat ve Bienaller*. Çev. Esin Soğancılar, *İletişim Yayınları*: İstanbul, 3. Baskı.
- Şahiner, R. (2008). *Sanatta Postmodern Kırılmalar ya da Modernin Yapıbozumu*. Yeni İnsan Yayınevi: İstanbul.
- Şaylan, G. (2009). *Postmodernizm*. İmge Kitabevi Yayınları: Ankara. 4. Baskı.
- Tezcan, M. (2011). *Sanat Sosyolojisi-Giriş*. Anı Yayıncılık: Ankara.
- Ulusoy, M. D. (2005). *Sanatın Sosyal Sınırları*. Ütopya Yayınları: Ankara. 1. Baskı.
- Whitham, G., & Pooke, G. (2013). *Çağdaş Sanatı Anlamak*. Çev. Tufan Göbekçin. *Optimist Yayın*: İstanbul.

Author Information

Mehmet Susuz

Abdulaziz Mahallesi, Abdülmümin Sokak, No:16, Meram,
Konya/Türkiye
Contact E-mail: msusuz@konya.edu.tr

Mahmut Sami Ozturk

Necmettin Erbakan Üniversitesi
Abdulaziz Mahallesi, Abdülmümin Sokak, No:16, Meram,
Konya/Türkiye

Pulling Back the Curtain ' The Relationship between Teacher Quality and Students' Educational Outcomes and Its Effect on the Communities Issues

Adel Dagher FAHED BUDAGHER
 Trinity International University

Abstract: It is very important to take heed of the following issues in the World of Educations: The quality of a teacher is the most important schooling factor affecting student achievement, and educational policy, in turn, has reflected this assessment, both by allocating substantial resources to improving and by assessing teacher quality. Yet in spite of this broad consensus, we have yet to identify which proxies of teacher quality best predict desired outcomes. Moreover, though there is a growing recognition that the effects of teacher quality may emerge slowly or be visible only with time, little attention has been paid to students' long-term outcomes, such as postsecondary degree attainment. Therefore, in order to gain a better sense of how different indicators of teacher quality represent and impact students' educational success, this study examines the relationship between two dominant measures of teacher quality, teacher qualification and teacher effectiveness, in terms of their influence on students' short-term academic growth and long-term educational success (measured by completion of a college degree). Since students are exposed to teachers of varying quality over the course of their schooling – and since achievement is closely related to that cumulative exposure – this study computes cumulative teacher quality indices that are able to more precisely estimate the impact of teacher quality. Considering how these common measures of teacher quality are already being incorporated into various teacher policies, including teacher salary and evaluation, this study will help develop more coherent and complementary policies regarding teacher quality. Ultimately, also, this study seeks to inform researchers, educational and community leaders, and policymakers about the ways in which low-income families embedded in CDCs access and mobilize educational opportunity.

Keyword: Teacher quality, Educational outcomes

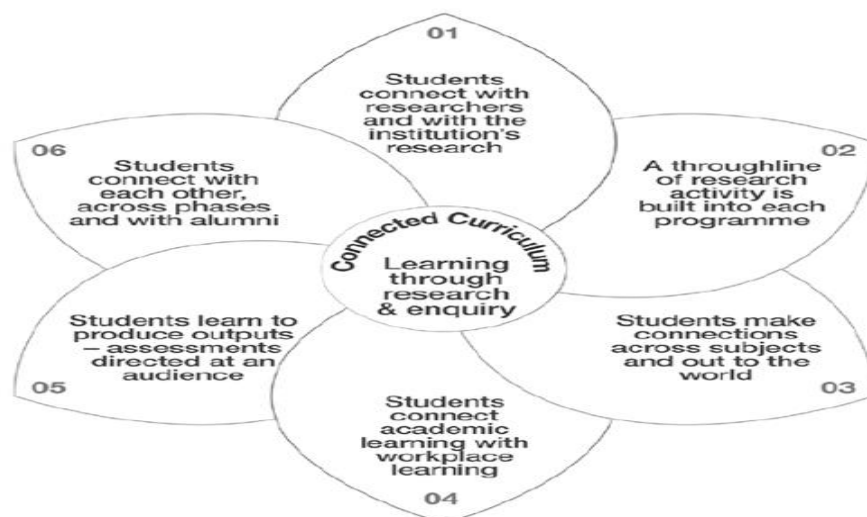

The Connected Curriculum Framework
The Six Dimensions of the Framework

Introduction

Teacher education programs can make a difference to student achievement depending on the type of education program and support that is put in place. Specific factors such as the years of teacher training, the teacher's verbal fluency, subject matter knowledge, having books and materials and knowing how to use them, teacher expectation of pupil performance, time spent on classroom preparation, and frequent monitoring of student progress are all key factors identified in some key research studies that have a positive bearing on the quality of teachers' performance and, consequently, student achievement.

When teachers are actively involved and empowered in the reform of their own schools, curriculum, pedagogy, and classrooms, even those with minimal levels of formal education and training are capable of dramatically changing their teaching behavior, the classroom environment, and improving the achievement of their students.

Conversely, when teachers are ignored, or when reforms come from above or are not connected to the daily realities of the classroom and local environment, even the most expensive and well designed interventions are almost guaranteed to fail. Our review of the literature and case studies confirm that when teachers are involved in making decisions about changes that affect them, enjoy being around children, have the skills to impart appropriate knowledge and manage their classrooms, and understand their role in the broader community, they usually are highly motivated and their students' achievement tends to rise.

Underpinning the Positive Learning Framework is an attitude: 'How to use these skills and strategies to develop environments where all students feel they belong and can trust others? Where they get tangible experience of mastery so they know they have talent? Where they have opportunities to be responsible and have power and independence? And where they feel worthwhile in their contributions and presence so that they see a purpose in showing generosity?' By learning to use the skills effectively, the quality learning environments will be developed by positive teacher– student relationships.

Educational equity, also referred to as equity in education. Is a measure of achievement, fairness, and opportunity in education. The growing importance of education equity is based on the premise that an individual's level of education directly correlates to future quality of life. Therefore, an academic system that practices educational equity is a strong foundation of a society that is fair and thriving. However, inequity in education is challenging to avoid, and can be broken down into inequity due to socioeconomic standing.

Conception of Knowledge: objective & separate from knowers

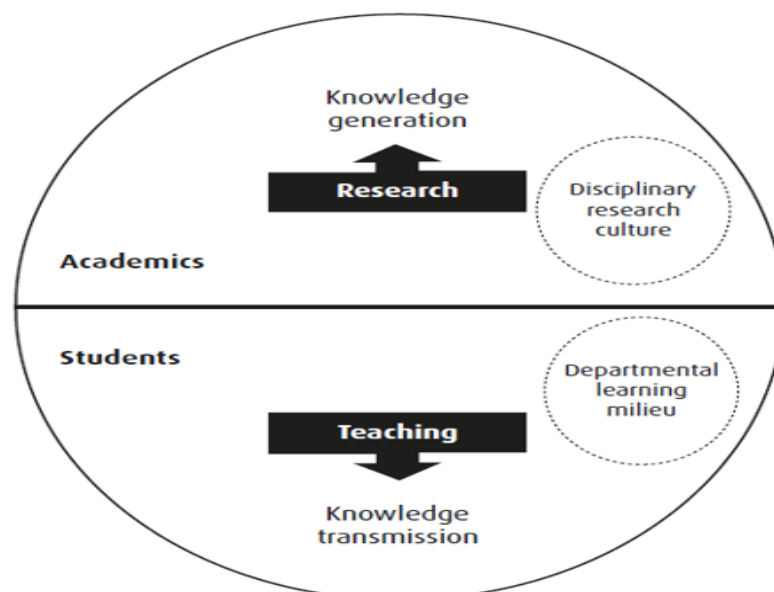

Conception of Teaching: teacher focused, information

Traditional Model of the Relationship between Teaching and Research

The Art of Teaching

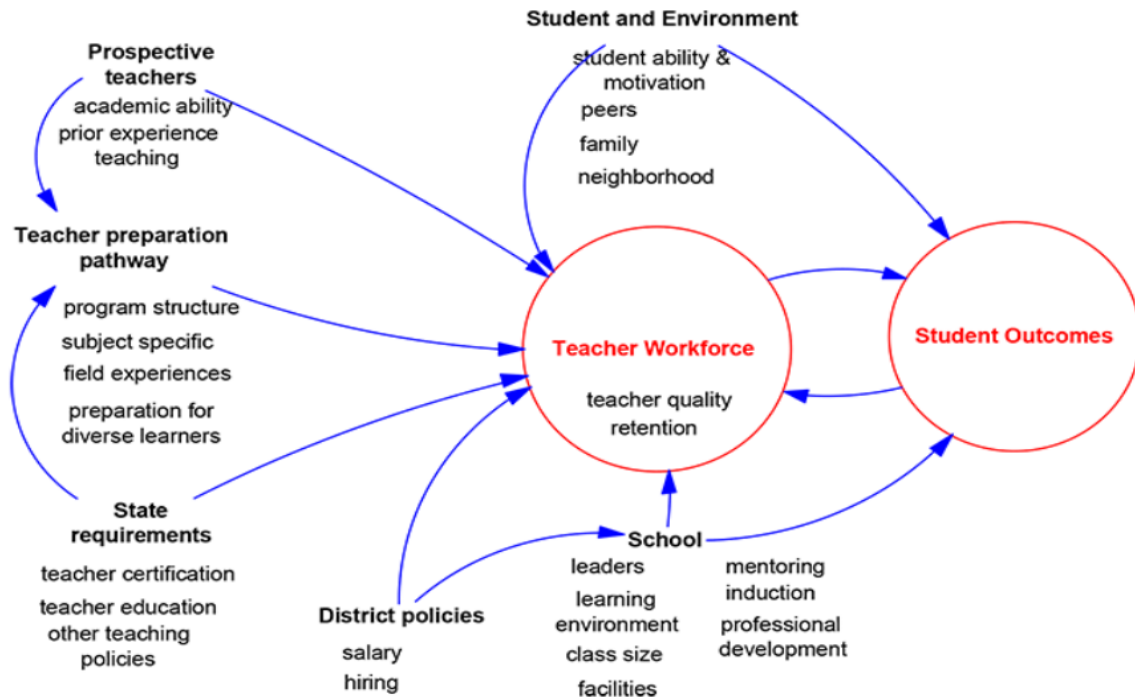

Education

The process through which we discover that learning adds quality to our lives. Schools/Technical Training Centers/Colleges and Universities.

Teaching Method

Objective oriented activities and flow of information between teachers and students.

What is Teaching?

- ❖ Teaching is a process intended for learning by inducing a behavioral change in the taught.
- ❖ It is an art of communicating a message with impact on audience.
- ❖ Pedagogy is an art or profession of teaching.

Why Teaching

- ❖ Teaching creates knowledge awareness and feelings in the taught and brings about behavioral change.

Type of Teaching

- ❖ Active.
- ❖ Passive.
- ❖ Learner Oriented.
- ❖ Teacher Oriented.

Teaching Methods

- ❖ Lecture.

- ❖ Lecture discussion.
- ❖ Seminar.
- ❖ Symposium.
- ❖ Panel discussion.
- ❖ Group discussion.
- ❖ Tutorials.
- ❖ Role-play.
- ❖ Integrated teaching (horizontal and vertical).
- ❖ Talking point sessions.
- ❖ Workshops.
- ❖ Conferences.

Criteria of Good Teaching

- ❖ Good Concept (thorough preparation).
- ❖ Organized Content (lesson planning).
- ❖ Good Quality and optimum quantity.
- ❖ Sequence.
- ❖ Relevance.
- ❖ Learner oriented.

Teaching Practice

- ❖ Set Induction.
- ❖ Introduction Topic.
- ❖ Topic Organization.
- ❖ Reinforcing or Stimulating.
- ❖ Summarizing.

Evaluation or Assessment

Impact Assessment

- ❖ Can be done in several ways.
- ❖ One sided (by teacher himself).
- ❖ Two sided (teacher and student).
- ❖ Third party assessment.

Evaluation

- ❖ Self-designed using the understanding of the learning objectives of the lecture as criteria.
- ❖ Basing on the basics of any lecture like the content, quality of presentation etc.

Worthy Points to Remember Regarding Teaching

- ❖ Teaching is an art (not just reading from a book and reproducing in the classroom).
- ❖ Teacher development is mutual with the student development and vice versa.

Managing the Students

- ❖ Do not throw the blame on the students for your failure to create an impact with your lecture.
- ❖ Students are immature, less skilled, and emotional and you are mature, more skilled and composed.
- ❖ Best way to control the students is by giving them best lectures.

Some Possible Problems

- ❖ Teacher gives a lecture rather than conducting a dialogue.
- ❖ Teacher talks too much.
- ❖ Students won't talk to each other or the tutor.
- ❖ Students don't prepare.
- ❖ One student dominates.
- ❖ Students want to be given solutions to problems rather than discuss them.

Small Group Teaching

- ❖ To develop intellectual and professional abilities, e.g. analysing, logical reasoning, evaluating evidence/data, appraising and judging perceptively, thinking critically, seeing new relationships, synthesising, speculating creatively, designing, arguing rationally, transferring skills to new context, problem solving.
- ❖ To develop students' communications skills: with peers, tutor, in "real world".
- ❖ To develop values, language and perspective of the discipline.
- ❖ To foster students' personal development: e.g. confidence, managing own learning.
- ❖ To develop group working skills.
- ❖ To challenge and stimulate students and tutor.

Conditions for Successful Small Group Teaching

- ❖ Effective planning and preparation.
- ❖ Breaking the ice -- starting out with the group.
- ❖ Keeping the group on track.
- ❖ Dealing with possible problems and conflicts.

The Group Successful Steps

Step 1
**Consider what you want the students to learn
or achieve: the learning outcomes**

Step 2
**Choose a suitable set of group tasks to deliver
the selected outcomes**

Step 3
Decide how to organise the small group:
Your tasks are to:

- prepare materials
- explain and check agreement on task
- monitor development of task
- control time boundaries

A Perfect Education System

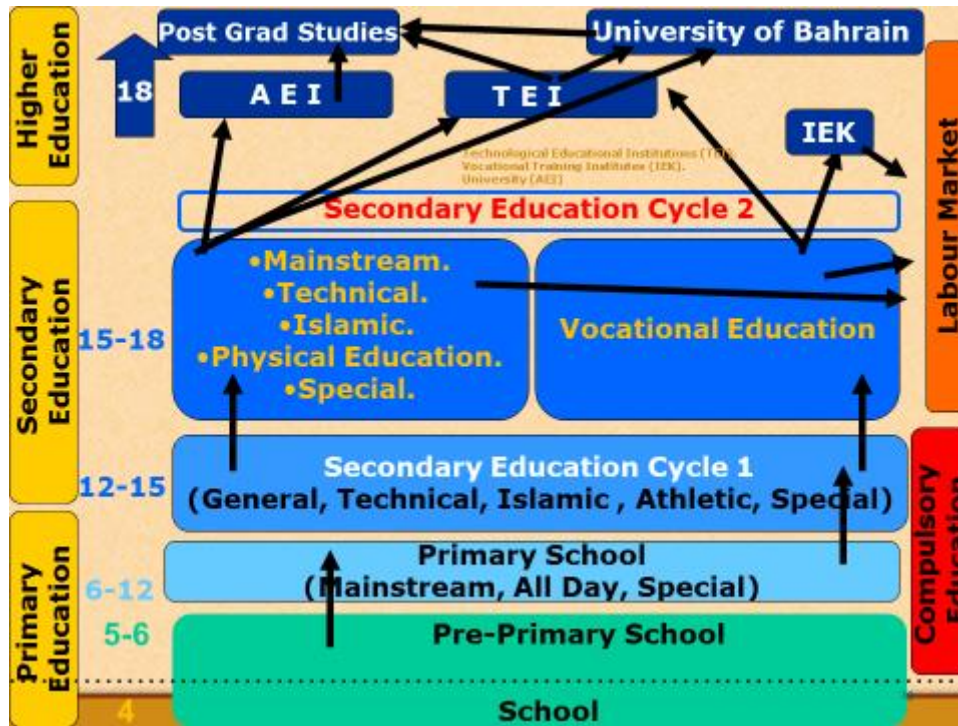

Schools as Organizations

- ❖ The schools that an individual attends shape not only his or her life chances but his or her perceptions, attitudes, and behaviors.”
- ❖ Education in any country is one of the nation’s largest businesses.

The Structure of Education

“To understand education, one must look beyond the classroom itself and the interaction between teachers and pupils to the larger world where different interest groups compete with each other in terms of ideology, finances, and power.” *School processes*, the way in which school cultures are created and maintained as per their needs.

Governance

Good part of education paid for by local property taxes, tax payers have much to say about how schools within districts operate, through community school boards.

International Comparisons

Most countries have a National Ministry of Education or a Department of Education that has considerable influence over the whole system. Most other systems not inclusive but have rigorous academic rites of passage.

School Processes and School Cultures

“The school is a unity of interacting personalities. The personalities of all who meet in the school are bound together in an organic relation. The life of the whole is in all its parts, yet the whole could not exist without any of its parts. The school is a social organism.”

Teachers’ pedagogic goals often difficult to reconcile with students’ social goals, and administrators’ organizational goals shared by neither teachers nor students.

“Because schools are so deeply political, effecting change within them is very difficult. Groups and individuals have vested interests.”

Bureaucracies characterized by explicit rules and regulations that promote predictability and regularity and minimize personal relationships, can suppress individualism and spontaneity.

“Schools, as they are now organized, are shaped by a series of inherent contradictions that can develop cultures that are conflictual and even stagnant.”

Four elements of change: conflict in necessary, new behaviors must be learned, team building must extend to the entire school, process and content are interrelated and how they go about change is important.

Teachers, Teaching, and Professionalization

Teachers are the key players in education but their voices are seldom heard and their knowledge is terribly underutilized, and even devalued.

The Nature of Teaching

“The central contradiction of teaching is that ‘teachers have to deal with a group of students and teach them something and, at the same time, deal with each child as an individual.’”

Rewards are derived from students, the only positive feedback many teachers get.

Very little is known about the links between teaching and learning.

The key in teaching is the exercise of control.

Few professions are as routinized and as creative, with few rules to what it takes to be a good teacher; one may be a sense of humor.

Teacher Professionalization

- ❖ Only partially professionalized, especially at the elementary level.
- ❖ Teacher socialization is very limited.
- ❖ Difficult to think of ways to educate inspirational teachers.
- ❖ Clearly a correlation between higher levels of preparation and professionalization.

Education System Chart

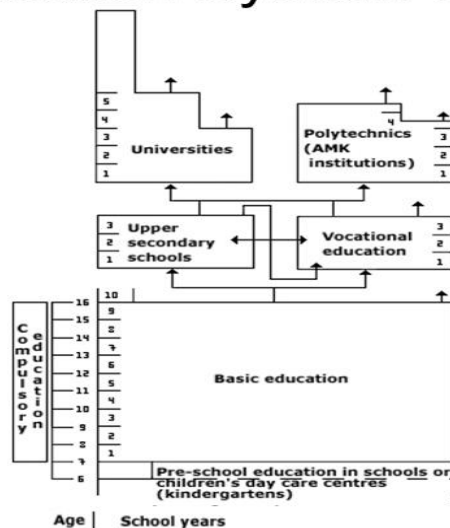

Quality Assurance and School Development

- ❖ The role in schools.
- ❖ The Evolving Education Landscape: System Change and Development.
- ❖ The Programme of Inspection in Schools.
- ❖ School Programme Evaluation.
- ❖ External Evaluation.

Quality Based

Performance indicators	Reflective Questions for
Teaching Organisation	How do teachers design their content and adopt teaching strategies according to their teaching objectives and student abilities?
Teaching Process	Are teachers' communication skills effective in promoting student
Feedback and Follow Up	Are teachers able to provide feedback to students to help them improve?

Framework for Thinking Through Quality Questioning

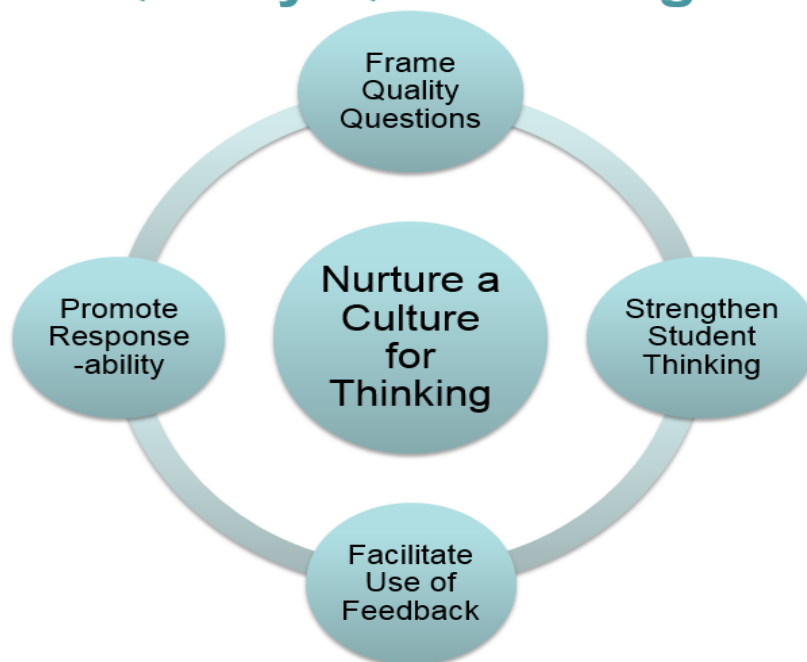

Whole School Evaluation

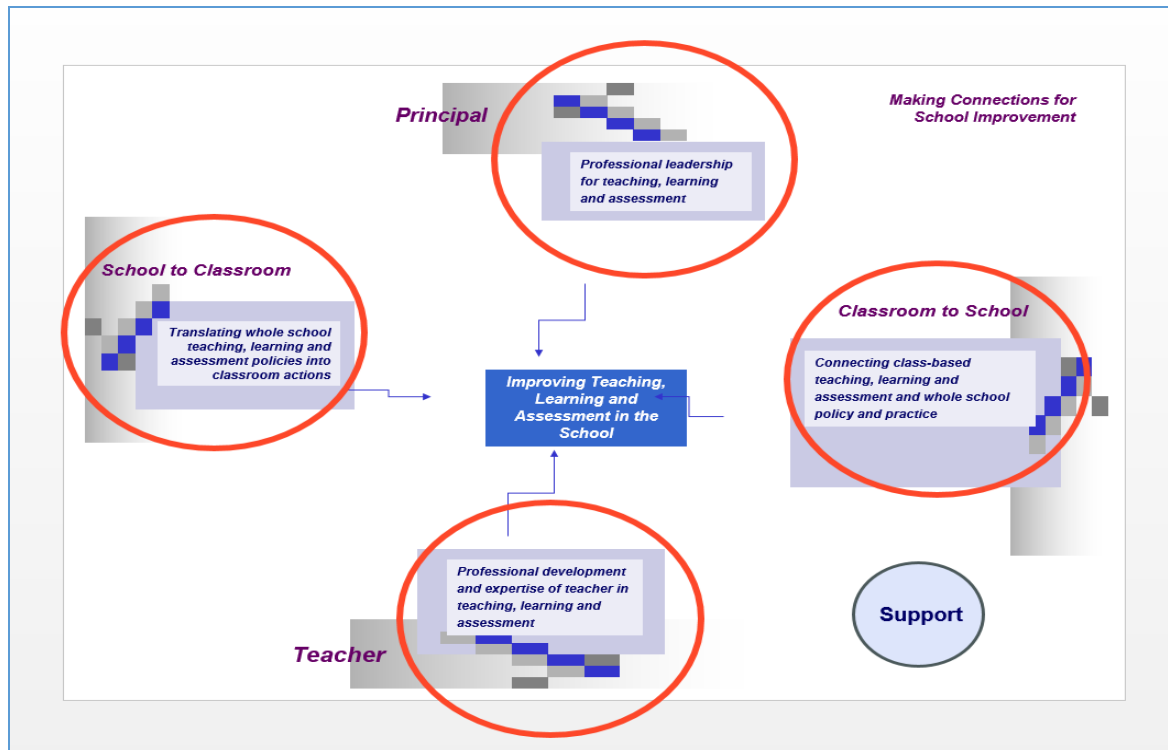
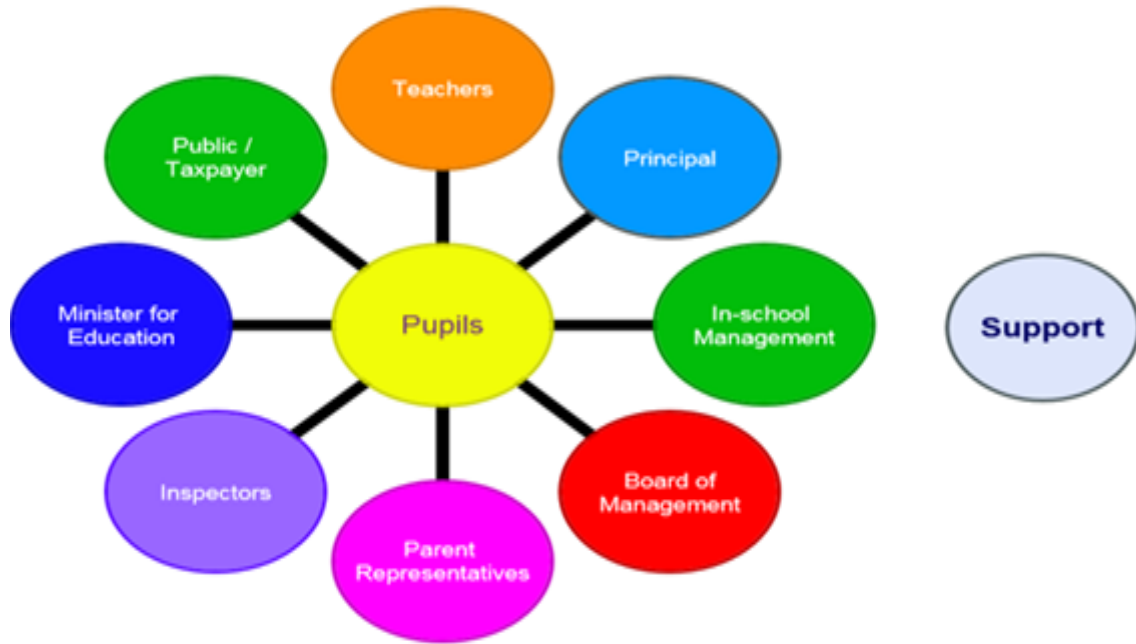

Effective Teaching

- ❖ Definitions of an effective teacher and effective teaching.
- ❖ The need for Triangulation of evidence.
- ❖ Value added measures – student progress and outcomes.
- ❖ Inspection perspective & external evaluation.
- ❖ Students' views and experiences.

- ❖ Research reviews of effectiveness.
- ❖ Observation of teaching – different measures.

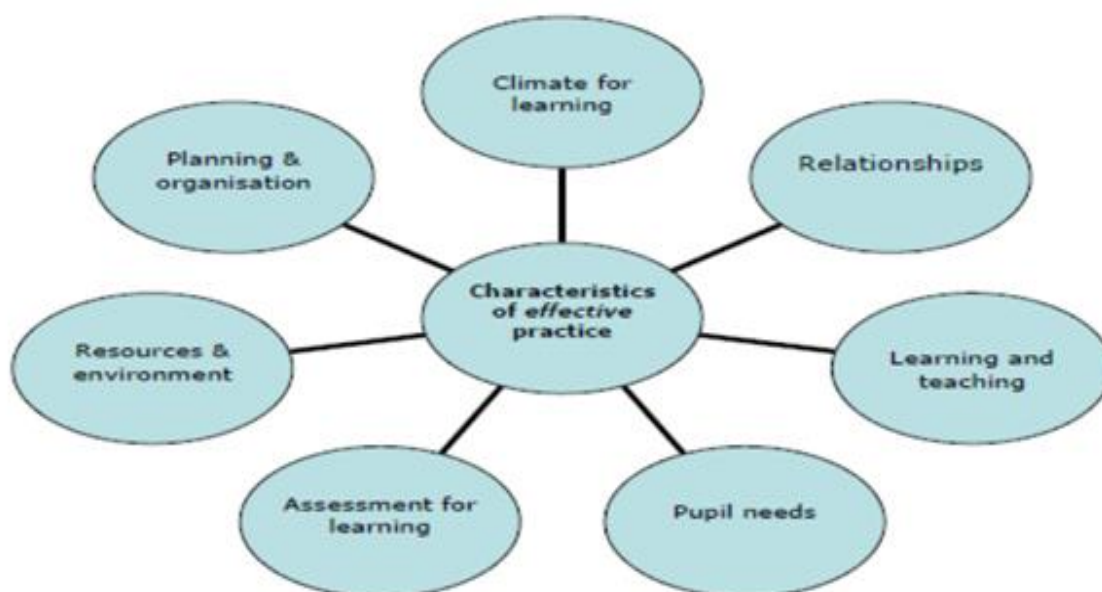

Integral Development

Innovation in Education: Regional Challenges in Education

- ❖ Limited access to primary and secondary education.
- ❖ Limited access to post-secondary education.
- ❖ Gender disparities in education enrollment in some countries.
- ❖ Rising violence in schools region-wide.
- ❖ Challenges with uncertified teachers and lack of teacher training.
- ❖ Physical infrastructure challenges, low spending and technology deficits limit the impact on educational access.

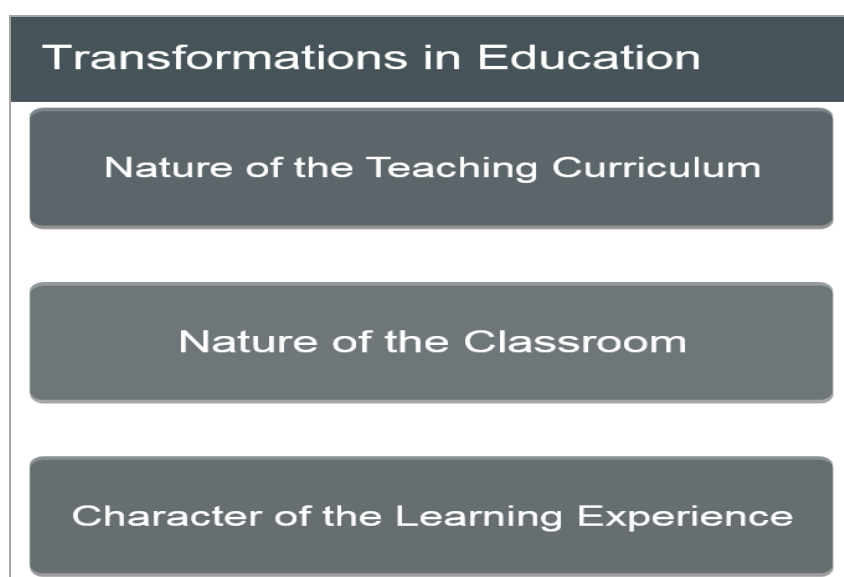

SMART

Learning Outcomes should be ‘SMART’

- ❖ Specific.
- ❖ Measurable.
- ❖ Achievable.
- ❖ Realistic.
- ❖ Timed.
- ❖ These have major implications for planning. However....

Linking Learning Outcomes to Levels

Hierarchy of learning e.g. Bloom’s Six Categories of Cognitive Learning

- ❖ Knowledge.
- ❖ Comprehension.
- ❖ Application.
- ❖ Analysis.
- ❖ Synthesis.
- ❖ Evaluation.

Bloom’s Six Categories of Cognitive Learning



Community Effects

Knowledge about the Community

- ❖ Connecting students to the outside world requires that teachers know their students’ community.
- ❖ Eating in the community, living in the community, reading local community papers, talking with community members, going to meetings of the community.

Sustainable Development:

“Sustainability is a journey. If we wait until we understand everything, we will never start out ...”

Education for Sustainable Development

To integrate the values inherent in sustainable development into all aspects of learning in order to encourage changes in behaviour that allow for a more sustainable and just society for all. This involves learning the values, behaviour and lifestyles required for a sustainable future and for positive societal transformation.

Crisis of Education

- ❖ The fact that we see social and environmental decay as disconnected events or fail to see them at all is evidence of a considerable failure that we have yet to acknowledge as an educational failure.
- ❖ It is a failure to educate people to think broadly, to perceive systems and patterns, and to live as whole persons.

A 'Sustainability Literate' Person

- ❖ Understand the need for change to a sustainable way of doing things, individually and collectively.
- ❖ Have sufficient knowledge and skills to decide and act in a way that favours sustainable development.
- ❖ Be able to recognise and reward other people's decisions and actions that favour sustainable development.

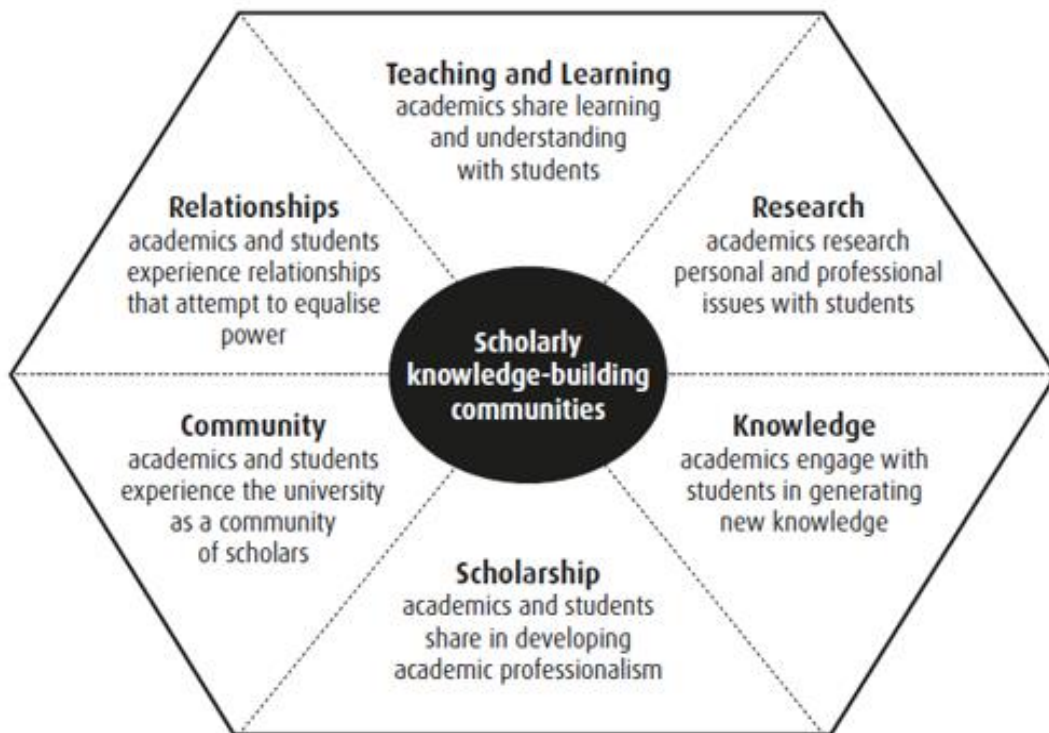

New Model of the Relationship between Teaching and Research

E - Learning for Education

- ❖ The use of internet technologies to deliver a broad array of solutions that enhance knowledge and performance.
- ❖ E- Learning is internet – enabled learning.
- ❖ Internet has started reshaping education.
- ❖ Education will not be the same in the next decade.
- ❖ There is no going back. The traditional classroom has to be transformed.
- ❖ Many universities/colleges may not survive by the end of this decade.

Results and Discussions

Classroom Climate -- Essential Components

Build trust with students

Set clear and consistent expectations

Create consistent routines and procedures

Create consequences for behavior together

Build a sense of community within the classroom

Create student 'jobs' for sense of ownership of classroom

Classroom Layout with Purposeful Design

Essential Components

Work Stations

Organization of Materials

Traffic Patterns

Physical Space

Teacher Interactions

Tone of Voice
Proximity to Students
Feedback to Students
Personal Discourse
Active Listening
Use of Humor
Use of Praise

Delivering Instruction- Essential Components

Scanning and Monitoring

Wait Time

Student Interests

Active Listening

Physical Movement

Motivating Student

Equitability

Animated Delivery of Instruction

Re-Teaching

Teacher Input Path Model

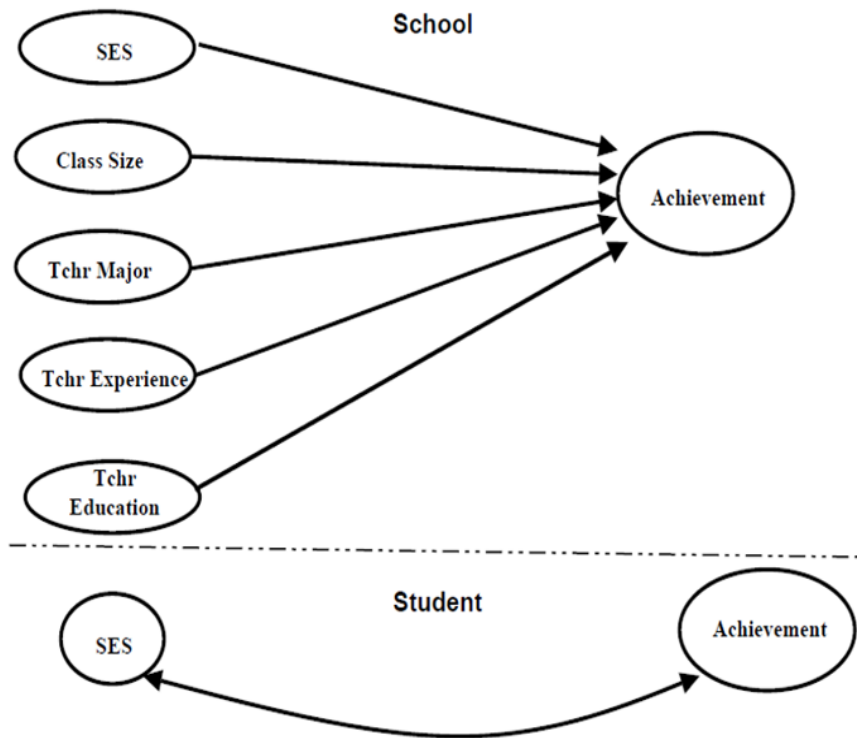

Professional development Path Model

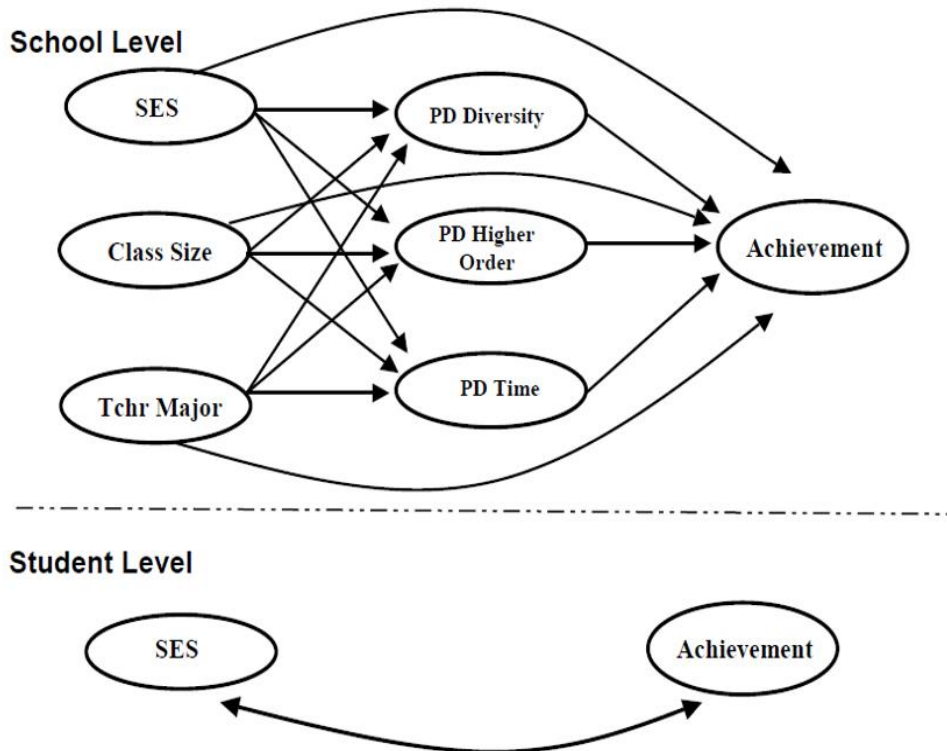

Classroom Practice Model

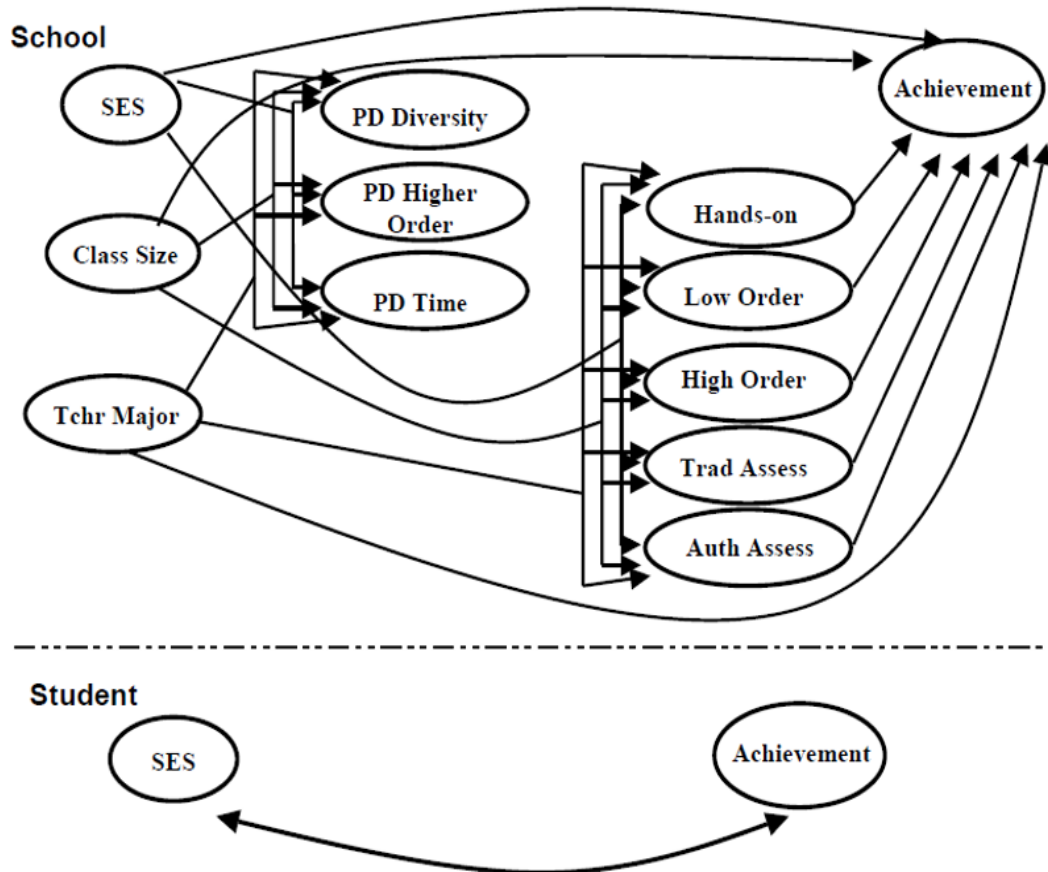

Conclusion

Self-Assessment

- ❖ What resources are needed to complete this?
- ❖ How much do I already know?
- ❖ What do I still need to find out?
- ❖ Can this be prioritised?
- ❖ What will help fill gaps?
- ❖ What is my action plan/time plan?
- ❖ How might I build on/IMPROVE previous work?
- ❖ Why is this topic important?
- ❖ What links are there between theory and practice?

Developed Teaching Tools

- ❖ Content knowledge.
- ❖ Pedagogical skills.
- ❖ Reflective skills.
- ❖ Communication skills.
- ❖ Management skills.
- ❖ Positive attitude and dispositions.

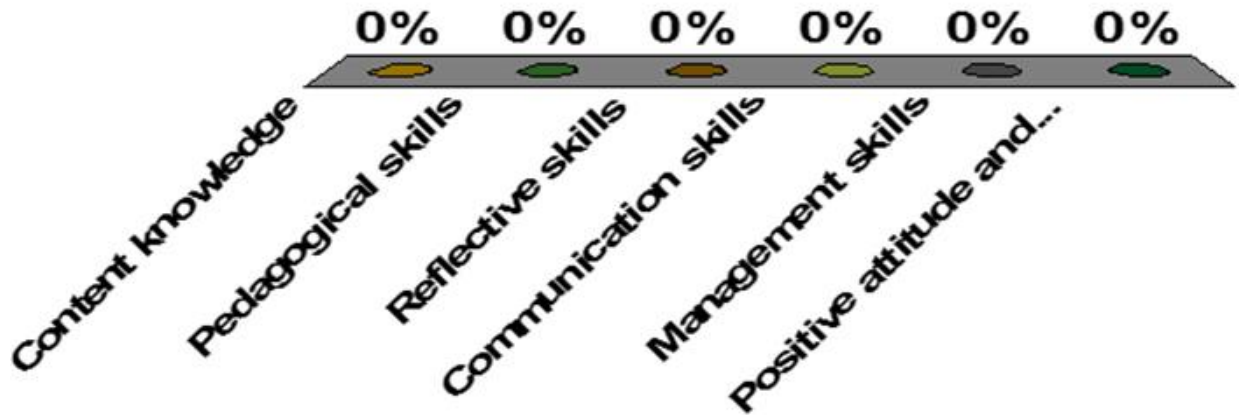

A Framework for Thinking about Questioning

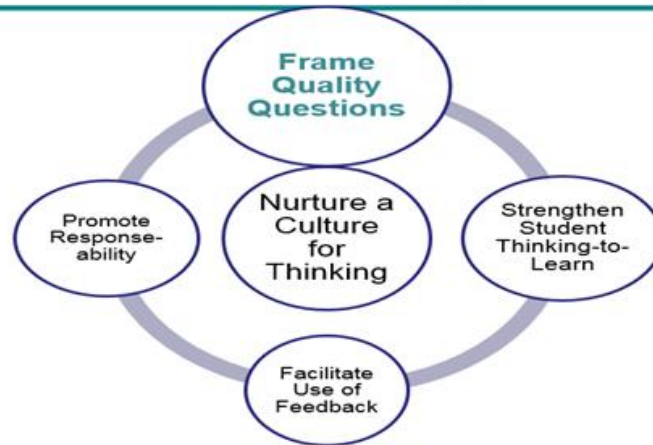

Constructive Alignment
the "Golden Triangle"



Key Questions

- ❖ In what ways does our practice advance the kind of learning, teaching, thinking and research that contribute to *unsustainability*?
- ❖ How do we balance practicability with urgency?
- ❖ What kinds of learning would best equip your students for their likely future(s)?

Students as 'Active, Engaged, and Effective Citizens' are

- ❖ Comfortable dealing with ambiguity.
- ❖ Willing to take a risk to make a difference.
- ❖ More interested in solving problems than taking credit.
- ❖ Both effective advocates and listeners.
- ❖ Eager to imagine and implement daring multifaceted solutions – together.

Recommendation

Fundamental changes in the following areas are required if the quality of teachers and teaching is to be significantly improved. Some key recommendations identified from the study are:

System Support

Establish commitment in the form of vision, policies, plans, and actions for long-term professional development of teachers. Some crisis management may be needed in the short term. Delegate to the school the authority, flexibility, and responsibility to develop relevant programs and school schedules to establish this long-term professional development commitment. Define the rights and responsibilities of the various administrative groups within the education system to clarify issues of needed legislation, infrastructure, functions, and communication. Require school supervisors to inform teachers and head teachers of promising teaching practices, and assist staff in trying these out. Assist schools to provide necessary teaching resources to achieve instructional goals.

Ongoing Professional Development

Provide focused instruction for new teachers. Beginning teachers need initial preparation in their subject matter, fluency in the language of instruction, knowledge of how to use instructional materials, and some basic classroom management and reflection skills. Most of these skills are best learned through on-the-job practice with coaching, which can be done through a traditional preservice program with substantial supervised practice teaching, or with close supervision and ongoing inservice training while on the job. Consider a range of alternative teacher preparation programs suitable to or adapted to local needs and constraints. Programs such as shorter school-based initiatives with ongoing mentoring and support should be considered, particularly in education systems with a great shortage of trained teachers. Establish an appropriate system of standards accreditation to match the preparation program so that *all* teachers can work towards both high standards and the same professional status.

Teacher Education Strategies in Developing Countries

More Effective Strategies	Less Effective Strategies
1. Grass-roots, bottom-up, teacher-centered reforms	Ministry of education designed and implemented reforms
2. Teacher centers–teacher circles focus	University or normal school focus
3. Learner-centered emphasis	Teacher-centered emphasis
4. Practice-oriented	Theory-oriented
5. Teacher-designed and written curriculum materials developed from ministry of education curriculum guidelines	Ministry of education-designed and written curriculum
6. Major expenditure of time and money on inservice training	Major expenditure of time and money on preservice training
7. Training primarily in school settings	Training primarily at universities, normal schools or ministries of education
8. Emphasis on actual classroom teaching behaviors	Emphasis on certificates and diplomas
9. Long-term inservice programs with extensive followup	Short-term inservice workshops with little or no followup
10. Teacher training as a life-long career continuum	Teacher training as a one-time preservice phenomenon
11. Teacher trainers with extensive experience at appropriate grade levels	Teacher trainers as university graduates with little or no experience in primary schools
12. Classroom teachers as textbook, workbook, and curriculum guide writers	University professors, with little or no school experience, as authors

THE INFLUENCE OF THINKING AND EMOTIONS ON BEHAVIOUR

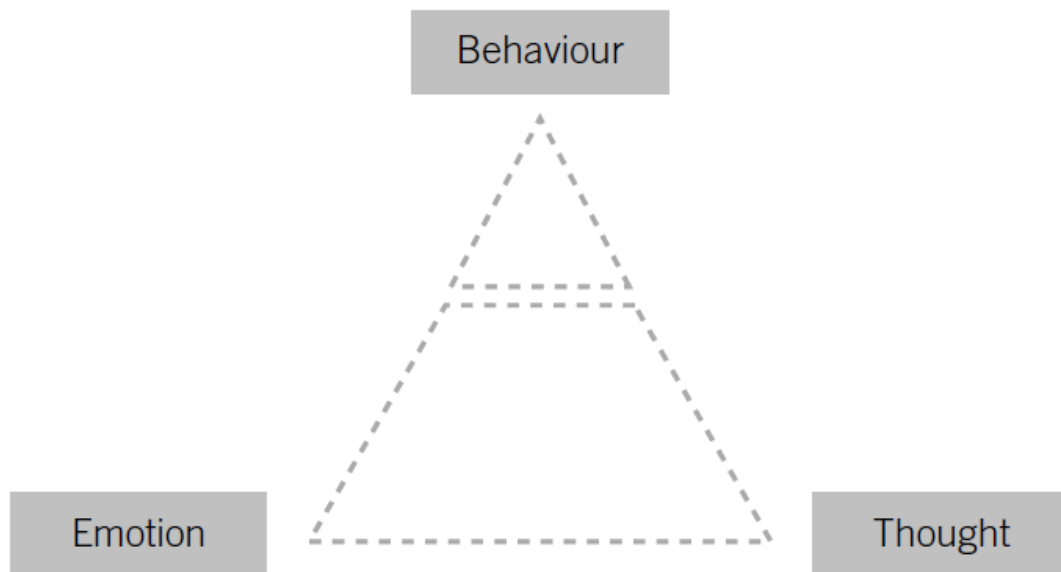

References

- Bartlett, L., (2005). Dialogue, knowledge, and teacher-student relations:Freirean Pedagogy in theory and practice. *Comparative Education Review*, 49:3, 344-356.
- Bracey, G.W. (2009). Identify and Observe Effective Teacher Behaviors. *Phi Delta Kappan*, 90, 772-773.
- Brophy, J.E. (1974). *Teacher-student relationships: causes and consequences*. NewYork, NY: Holt, Rinehart and Winston.

Author Information

Adel Dagher Fahed Budagher

Trinity International University, AMA International
University Counselor For Higher Studies,
P.O. Box 15277adliyanamakingdom of Bahrain. Bahrain
Contact E-mail: adel.dagher@garmco.com

Arabic and English Conditional Clauses: A Comparative Study

Samar Sami HAMMADI
Al-Turath University

Abstract: According to a study done by Covitt (1976), Conditional sentences ranked fifth on a list of most serious teaching problems encountered by ESL teachers. Hence, this paper aims to conduct a comparative study of conditional clauses in Arabic and English, to discuss some of the difficulties facing the students and English language learners in understanding the conditional structure and its translation from Arabic to English and vice versa. Conditional sentences and its structures are difficult sometimes become confusing for some students so they may become a puzzle that is hard to understand. Studying the conditional structure in general, and our understanding of its nature and the functions of its structure, helps us as educators and linguists to reach to our students' needs who find difficult to perform conditional clauses in Arabic and English and translated them correctly. Therefore, 40 lecturers had been asked about the difficulties in conditional clauses in order to focus on what should be done to analyze these difficulties encountered by students and language learners in the field of teaching in both Arabic and English. In this vein, the study aims to discuss the following aspects; first, the concept of conditional clauses and its classification in Arabic and English. Second, summarizes the similarities and differences of conditional clauses in both languages. Third difficulties that students face in learning conditional clauses and; finally, explore and clarify strategies for conditional clauses used to teach them to the students.

Keywords: Conditional clauses, Arabic, English, Strategies, Students

Introduction

It is important when presenting ideas in any language one must create a logical, linguistic relationship between them, relationships such as contrast, addition, expressions and condition is one of them. Every language has its methods of forming conditional sentences; however, each language has its way to express conditional sentences such as English and Arabic. Translators must know the particular structure indicates the condition of the target and source languages, then translate it into its equivalent structure.

In English, there are different possibilities; real, unreal, possible and impossible or hypothetical (AboAnzeh, 2006, .P 297). Besides, forms, meaning, tense all these elements of conditional structure are difficult for learners while mother-tongue language (Arabic) conditional clauses are easier to produce.

Most English language learners face difficulties in conditional clauses and sometime they are confusing and become a puzzle that is hard to understand, although, the structure is similar to linking verbs such as "because", "when", "and" etc., these difficulties lead many researchers study the reason behind delayed the usage of conditional clauses by children in many languages such as English, German, Turkish and others (Newcombe, 1996, 240). There are common denominators among languages, especially in conditional sentences that is, these sentences contain virtual and imaginary positions far from reality and the relationships that are almost metaphysical, tangible or intangible far from reality, or concrete, which sometimes causes us to go beyond the limits of logic and familiarity in our thinking and our beliefs. Therefore, contribute in our quest to understand the nature of our behavior, our ideas, our attitudes, what stands behind them, and what drives them to be as they are now.

From these points, studying conditional structure in general, and our understanding of its nature and the functions of the structure help us as educators to meet the needs of our students who may find it difficult to learn conditional clauses in English and translated correctly.

Arabic and English Conditional Clauses

Although there are differences concerning conditional clauses in English and Arabic, but both languages contain two main clauses "if-clause" which refers to the condition (subordinate) and the result clause. The important point is that the main action happens if the situation in if-clause is fulfilled (Abu Anzeh, 2006, p 298)

English Conditional Clauses

Conditional sentences based on the relationships between a conditional verb and its answer which can be real or hypothetical depending on our understanding and the intention of the speaker. Conditional clauses refer to cause and effect indicate as antecedent clause and consequent clause. The antecedent is defined as a subordinate clause referring to a supposition situation, while the consequent consists of a proposition situation that occurs if the antecedent is realized (Alexander, 1988, p. 27).

Yule (1998, 125) refers that English has three main states; factual state, real possibility and the hypothetical state described by an antecedent:

Nowadays, if people want something they can buy it (actual state)

If you lend me some money, I will pay you back..... (real possibility)

If I were you, I would help him..... (hypothetical state)

Larsen-Freeman (1999, p. 62) said there are only three types of conditional clauses; past, present and future. Grammarians like Yule (1998) and Wu (2012) said there are four types of conditional; zero, future, present and past conditionals.

Conditional clauses falls into two parts real and not real depending on the verb of the antecedent. In real structure, the antecedent part indicates a condition, the reality of which is unsubstantiated and the verb in the result clause can be in three tenses, past, present and future. In unreal conditions, the antecedents indicate a condition that is known to be false or impossible (Palmer, 2001, pp. 78, 125, 208).

According to Quirk et al. (1985, pp. 91-97) there are four types of conditional clauses:

1. Zero conditional: This type used to describe facts, scientific facts, rules or anything that's true. The structure of this type is present simple for both antecedent and consequent clauses:
If you like it, we do it.
2. First condition: this type refers to possibilities, potential which could happen in the future. The tense of this type is either present or future and modals can be used such as (can, may and should)
If you work hard, you will promote.
3. Second condition: it is used for imaginary and unreal event in the present or future. Past tense is used in this type to indicate present or future.
If I were you, I would take it
4. Third condition: it is used for unreal or impossible event (didn't occur) in the past. The structure can be with past perfect.
If I had gotten the job, I would have started a new life.

According to Haegeman (2009, pp. 33-43) there are different ways of expressions implied condition in English. One of these ways to form conditional sentence is using "if-so". Instead of repeating, we can use *so* and *not* or negative clause (*Have you got a free ticket or the concert? If so, let's tell Ali*).

(*If- only*) used with past referring to present or past perfect referring to past for strong wish or regret (*If only you had more money, you could buy that house*).

Mixed tense, in which the time of the antecedent is different from result clause. One clause can be in present and the other in the past (*if I had done my work this morning, I would go with you to the cinema*).

Sometimes, (*If*) is not exist or just omitted and the verb and the subject represent the conditional sense (*You do this again, I'll kill you*).

Double negative used in an informal speech where sometimes there is additional (*not*) in (*if-clause*); however, it doesn't indicate negative meaning (*I wouldn't be happy, if she didn't tell him*).

There are words and phrases can place (*if*) and give the same meaning: *that, as/so, unless, one condition that* and etc. (*I will give the car, on condition that you finish your work.*

(*Otherwise*) used to indicate the negative condition (*do your work, otherwise you will be out*). Also, (*whether.. or*), and (*whatever*) can be used to indicate conditions (*whether you cried or not, we will go without you*).

Conjunctions also used to implied condition such as *and, or, only* and *but*:

Do as required, and you will be happy.

Do your works or you shall be punished.

He would have a new car, only he had enough money.

David would have shot the pig, but the lion had come very fast.

Arabic Conditional Clauses

Arabic conditional clauses have three main particles to indicate if- clause (لو, إذا, إن) and they have different use and meanings. For instance, (لو) it refers to unreal, something impossible of contrary to fact, such as (*If I were you*). It can be in past, present or future (Abu Anzeh, 2006, pp. 297-30).

(*If he had studied, he would have succeeded*) لو درس لنجح

(*If I had a thousand dollars, I would buy a car*) لشترتيت سيارة دولار ألف معي كان لو

(إن) indicate conditional if-clause without referring to possibilities

) (*If he studies, he will succeed*) إن درس نجح

(إذا) indicates some degree of possibility just like *when, whenever*.

) (*If we go by train, we shall be late*) إذا ذهبنا بالقطار فسنتأخر

There are other particles which can be regarded as conditionals. Some of these particles are (ما, متى, من, أما) (ibid), أيا.

Similarities and Differences between Arabic and English Conditional Clauses

This section studies the similarities and differences in order to overcome difficulties of learning and translating conditional clauses between Arabic and English.

Similarities

As we said previously that conditional clauses in English and Arabic have (if-clause) and (result clause) which means the main structure of conditional clause is similar in both languages.

In Arabic the conditional verb could come independently from the result or it comes after just like in English and also it could have حتى, إلا, و:

الاحد إذا أردت أحضر الى المكتب

Come to the office Sunday, if you want to

سأذهب الى المتحف إذا زرت تركيا

I will go the museum if I visit Turkey

لن يسمح لك بالسفر إلا إذا اكملت دراستك

You will not be permitted to travel unless you finish your study

It is important to say that *unless* can be translated as (إلا إذا) and also to (لو لم, إذا لم).

Wickens (1980, p. 77) refers to an important point that most languages share, including English and Arabic, that is conditional clauses can appear as an imperative form without conditional particles:

أدرس تنجح

Study and you will succeed

However, not all conditional clauses can be in imperative form, especially relevance conditionals those with one possibility:

If you are David Sami, the money for you

It cannot be: *Be David Sami and the money for you*

Differences

Despite these similarities, also there are many differences between Arabic and English conditional clauses. English, for instance, focuses on the verb while using the same conditional particle (if) while Arabic focuses on the changes of conditional particles with the same verb (Abu Anzeh, 2006, p. 297):

1. لو ذهب means (If he had gone) which means he didn't go
2. إن ذهب means (if he goes) which means he might go
3. إذا ذهب means (if he goes) which means he might go

Moreover, in Arabic the result clause verb and condition clause verb can come in the same tense (perfect tense):

1. إن ذهبته فابلته If I go, I will meet him
2. إذا ذهبته فابلته If I go, I will meet him
3. لو ذهبته فابلته If I had gone, I would have meet him

We can see from the examples that the verbs of the conditional and the result clause in Arabic come in the perfect tense with different conditional particles, whereas in English tense changes happen in the verb of the conditional and result clauses.

One of the difficulties that face learners that is the verb (would) has no similar meaning in Arabic and also the conditional particle (لو) followed (ل) which does not exist in English.

In addition, the tense that indicates an unreal situation in English is the past perfective, while in Arabic conditionals is the perfect tense.

Difficulties in Understanding English and Arabic Conditional Clauses

In English, some sentences may have the form of conditional sentences, but they indicate something else like a promise (*I will give you money if you clean the dishes*) it is a problem for Arabic students in understanding the sentences and translate them correctly.

Another problem that students face is that the conditional sentences can be formed without using conditional particles as has been previously explained (*Come early, and you will get it*).

In order to understand the difficulties that students face in translating and learning conditional clauses, an interview made with 40 lecturers (M.A and PhD. Holders) with English grammar specialties from different universities have been asked about the problems that students face.

They said conditional clauses with present simple and future less difficult for students with an average level and conditional clauses with present perfect is the most difficult for all levels. Also, they said most students made mistakes when the conditional clause comes after result clause more than when it comes at the beginning of the sentence. Around 65% of the lecturers said that the changing of the form to different tenses is confusing to the students because conditional structures are formed with different tenses that do not refer to the time state whereas they do not excite in Arabic conditional clauses. Sentences that do not have conditional *if*, but implied condition are difficult for students to translate them into Arabic conditional clauses. It is obvious that *if*-clauses convey a condition; however, the problem is that the students mix between these types and unaware of the specific uses of each type.

Strategies for Teachers in Teaching Conditional Clauses

According to what have been discussed earlier, the study comes with strategies for teachers to help their students overcome the difficulties of conditional clauses:

1. Students must learn first sentence types, tenses and conjunction before learning conditional clauses.
2. Teachers must start with the easier type, like *if*-clause and then other types like using *when*.

3. Following the sequence in teaching conditional clauses starting with real condition and then to unreal or imaginary condition so that students can be able to distinguish between them.
4. Sentences that have if-clause, but do not imply a condition like (*if you please*) lead us as teachers to focus on the context not only the structure while teaching students conditional clauses.
5. Teachers can follow Chomsky's theory TGG (Transformational Generative Grammar) which indicates that some transformations can be performed on linguistic structures in order to clarify some ambiguous meanings in the conditional structures and; thus, understand the deep meaning of the sentences. These transformations are substitutions, deletions, binding, and rearrangement of the sentences.
6. Teachers are advised to teach conditional structures through different situations and different stages in order to give the students enough experience to understand the structures and how to use in life to express wishes, requests, clarification of facts and potential to expand students' perceptions and abilities to think, analyze, connect, imagining and understanding the relationships between things as they are.
7. Teachers should teach conditional structures based on encouraging students to express themselves, their desires and open the horizons in front of their imagination to enable them to use conditional structure in a communicative manner are close to their reality: for example, (*If I were a doctor; If I were you...*).

Conclusion

Teaching English conditionals has always been a difficult task for English teachers. Therefore, the study aims to explore and clarify the nature of conditional clauses in English and Arabic in order to overcome the difficulties that students face. There are a number of differences between English and Arabic conditional clauses; because of these differences the students face some difficulties in understanding and translating the conditional clauses. Thus, the role of the teachers is to reduce these difficulties by teaching them conditional clauses gradually and in the right way, that's why the study comes up with certain strategies for teachers to help their students to understand conditional sentences and all its types.

References

- Al-Mashtah, Majeed Abdul-Haleem.(2010).*Al-lughatu Al-arabiah wa Allissaniatu Al-Mua'sirah*. Al-Basra:Matbaat Al-Nakheel .
- Abu Anzeh, A. (2006). *Sound approach to English grammar*. Qatar: Dar Yafa Al-Elmia For Pub.
- Covitt, R. (1976). Some Problematic Grammar Areas for ESL Teachers. MA Thesis. Los Angeles: University of California,
- Haegeman, L. (2009). The Syntax of Conditional Clauses. *University of Siena*, 29-50. doi:<http://www.diacronia.ro/ro/indexing/details/A22685/pdf>
- Hammadi, S. & Al-Ahmedi, M. (2015) A Semiotic Analysis of Threat and Warning Symbols in George Orwell's Novel 1984. *International Journal of Research*. 11(2) 493-498.
- Hammadi, S. (2018). Messages behind Images: A Semiotic Analysis of Mother Movie R. Barthes's Theory. *Mustansyia College of Arts Journal*. 82(A).472-484.
- Hammadi, S. Al-Bahrani, R. Al-Saadi, S. (2015). Students' Ability to Diagnose Threat and Warning Act Clues in George Orwell's Novel "1984". *International Journal of English and Education*.2 (4) 356-273.
- Larsen-Freeman, D. (1999). *Techniques and principles in language teaching* (2nd ed.). New York: Oxford University Press.
- Palmer, F. R. (2001). *Mood and modality*. Cambridge: Cambridge University Press.
- Wu, M. (2012). The Probability Approach to English If-conditional Sentences. *Canadian Center of Science and Education*. 5(5). 37-44.
- Quirk, Randolph, Greenbaum, Leech and Svartvik. (1989). *A Comprehensive Grammar of the English Language*. London: Longman.
- Slaton, R. L., & Newcombe, N. (1996). *Study guide to accompany Newcombe, Child development: Change over time, eighth edition*. New York: HarperCollins College.
- Wickens, G. M. (1980). *Arabic grammar: A first workbook*. Cambridge: Cambridge University Press.

Author Information

Samar Hammadi

Al-Turath University

Baghdad, Iraq

Contact E-mail: *sa88802000@yahoo.com*

Designing Investigation Methods to Research Indiscernible Impediments of an Invisible Equity Group in Australian Higher Education

Ganesh KORAMANNIL
Charles Darwin University

Abstract: Research related to Australian Indigenous people is of national significance and is full of challenges as well as opportunities for both Indigenous and non-Indigenous researchers. It requires cultural sensitivity, innovation and pragmatic approaches to frame the enquiry to reach its intended outcomes. Indigenous students are the most marginalised equity group at Australian universities and some aspects of their access and success at university, especially those related to the use of English as the sole medium of instruction, are yet to be explored thoroughly. A grounded approach to the research was guided by the advice of Indigenous mentors of the researcher. The host university's strong commitment to the compliance of ethical practices for Indigenous research combined with the collective experiences of the mentors and the researcher in Indigenous education informed and guided the drawing up of a pragmatic and culturally sensitive research framework. This paper outlines the development of a framework to investigate the potential language barriers encountered by Indigenous students from EALD (English as an additional language or dialect) backgrounds at a regional Australian university.

Keywords: EALD, Education, Indigenous education, Higher education, English as an additional language

Introduction

This chapter provides a description of the genesis of the research plan and its purpose during the doctoral research into the potential barriers encountered by Indigenous students from English as an Additional Language or Dialect (EALD) backgrounds at an Australian university. Difficulties with accessing course materials and performing well in assessments is part of student experiences and in general, research into the experiences of Indigenous students is limited (Day and Nolde, 2009). It is also noted that these students face multitude of barriers (see Oliver, Rochecouste, Dann, & Grote, 2014).

The researcher's EALD, multilingual, multicultural personal backgrounds and professional practices helped relate with EALD Indigenous students' numerous English and academic language issues at the university. It has been confirmed that learning in a language not spoken at home would disadvantage learners (Siegel 2010) and most Indigenous students learn Aboriginal English (AE) and Standard Australian English (SAE) at home (Sharifian, 2006). English language and literacy skills have already been found critical for successful student engagement in tertiary education ((Malcolm & Rochecouste, 2003; Malcolm, Rochecouste, & Hayes, 2002). Insufficient English language proficiency and academic language skills could therefore become detrimental to course outcomes, and hence it was hypothesised that Indigenous students from EALD backgrounds could be facing the same or similar difficulties like any other 'non-English-speaking' student. Researching this initially required establishing the presence of these students at the university; however, the literature review undertaken only confirmed their invisibility (Koramannil, 2016). Further, researching this required examining the English and academic language barriers they encountered.

Researching least ventured-in areas provides augmented challenges and opportunities

The Research Context

This research situates centrally within the domain of Indigenous Education an area that has had ‘ongoing policy focus and repeated official inquiry’ (Gray and Beresford, 2008). Indigenous higher education itself has a visibly significant history (see Wilson and Wilks, 2015) and has its inherent complexities.

Indigenous Australians are the traditional owners of their respective territories in Australia and therefore, they are also the established custodians of the languages, culture, spirituality and the wellbeing of the land. However, Colonization of Australia took away their right to their land, their right to speak the language and the freedom to practice their culture. Even after the referendum that provided Indigenous Australians with Australian voting rights and citizenship, their socio-economic conditions, life expectancy and participation rates in education and employment have remained far below the national standards. An alarmingly wider gap exists between the living conditions of Indigenous Australians and the mainstream Australian society.

This gap is significantly evident in education as well. There are far fewer Indigenous students than their mainstream counterparts attending schools in Australia and those who attend fare relatively far below the national averages of academic performances. Indigenous participation in higher education has also remained far below parity compared with non-Indigenous Australians (see Day, Nakata, Nakata and Martin, 2015).

Indigenous Australians form the most disadvantaged equity group in Australian higher education. Many of them face many traditional barriers encountered by equity groups in general.

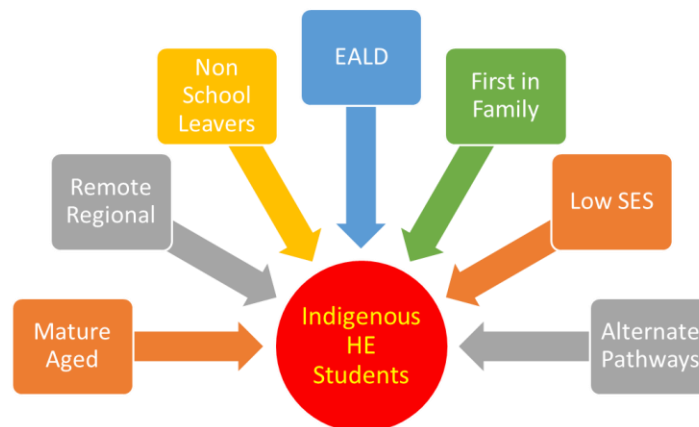

Figure 1. EALD background of indigenous students: One among the many possible disadvantages

To name a few, low socioeconomic conditions, health problems, impediment of distance for students from regional and remote Australia, and having to seek alternate entry pathways to university, have posed traditional barriers for these first Australians. Indigenous students, especially from the rural and remote parts of Australia, speak a language other than English as their first language. This could be a traditional Indigenous language, a Creole or one of the many varieties of Aboriginal English. In fact, many of these Indigenous Australians speak more than one language at home and in their communities and for some, English could be the third, fourth or even the fifth language they speak.

The problem

The evident disparity in Indigenous students gaining university education in Australia is sustained by low rates of enrolment coupled with significantly lower retention and completion rates (Behrendt, Larkin, Griew, & Kelly, 2012, Wilks & Wilson, 2015, and Edwards & McMillan, 2015).

There are many problems that are attributed for the considerably poor rate of participation of Indigenous Australians in higher education. Some of the traditional impediments that have been identified and intensely researched have gained acknowledgement and greater acceptance in the mainstream society. O'Rourke (2008) looked at the perceived institutional barriers for Indigenous students in the universities and identified six such obstacles. There is clear understanding that remote and regional Australia encounter notable educational

disadvantage (Human Rights and Equal Opportunity Commission, 2000) and many Indigenous students reach universities after overcoming this 'tyranny of remoteness'.

Another barrier that has been identified as preventing Indigenous students from accessing education is the significantly low social economic status (SES) backgrounds they come from (see Blyth 2014, and Cardak and Ryan 2006). This not only incapacitates these students from accessing resources but also has a significant impact on their health and wellbeing. It is well documented that a high proportion of Indigenous people and therefore, Indigenous students, face severe health problems. The significant gap between the life expectancies of Indigenous and non-Indigenous Australians is enough evidence for this aspect as a barrier.

Poor attendance, early attrition, and health issues among other factors have set traditional barriers for Indigenous school education (Gray and Beresford, 2008) and this, in turn, have proven to be impediments for Indigenous students aspiring for University education. As a result, many Indigenous students reaching Australian universities are mature aged and/or non-school leavers. Many Indigenous students at the universities also take the VET (vocational education and training) pathways through which they are admitted to undergraduate programs at the university by virtue of a Certificate III or IV qualification in any area. This is made possible through the widening participation agenda and policy initiatives to improve Indigenous enrolment at universities and this has provided Indigenous students with multiple pathways to Australian universities.

A significant fact and a potential barrier that never gets considered in this context is the fact that many Indigenous Australians do not speak Standard Australian English (SAE) as their traditional home language and this cohort remains invisible within the system (see Koramannil 2016). As a result, none of the above-mentioned pathways are equipped with mechanisms to ascertain whether these students bring enough English and academic language skills to the university and if they are study-ready in terms of their English and academic language competencies.

A student who receives a letter of offer to study at the university can be assumed to believe that they have met prerequisites to commence university education. Similar assumptions are made also by their family and relevant university staff including lecturers, mentors and course coordinators. Thus, the university system and people who engage with these students at the university remain oblivious to a barrier that the students almost certainly encounter on commencement of university education.

Initial efforts by the researcher to understand English and academic literacy barriers faced by Indigenous students at Australian universities provided little evidence or insight. Other than an earlier attempt by the researcher (see Koramannil 2015) to highlight the linguistic similarities between EALD Indigenous students and others from similar English language backgrounds, there was significantly negligible reference to this problem in research literature as well as in relevant policy documents. The invisibility of the linguistic identities of Indigenous students was thus established in a preliminary literature review by the researcher (see Koramannil 2016) which brought out the potential for related language barriers.

The Context of English Language Requirements

Australia has traditionally been a very popular destination for international students and their numbers continue to grow (Department of Education and Training, 2018). One key reason for this popularity is the fact that Australia offers education only in English and many students coming to Australia benefit from the English language exposure they perhaps do not have in their home countries. Also, traditionally the importance of having adequate English language proficiency has been identified, acknowledged and enacted in policy documents and admission practices at Australian education institutions. As a result, English language proficiency is included as one of the key prerequisites for international students' entry to Australian universities. See Arkoudis, Baik and Richardson (2012) for an elaborate discussion on English language standards in Australian higher education.

Today, there are multiple ways in which aspirant international students can demonstrate their English proficiency (see O'Loughlin, 2015). This could be done by scoring the threshold or above threshold English language proficiency benchmark in one of the acceptable international English language examinations including IELTS, TOEFL and PTE. Students may also produce evidence that their schooling and/or previous qualifications were gained in acceptable English language environments to gain admission to Australian universities.

In case they don't meet any of these English language criteria, there is the alternative of dedicated English language pathways to enter Australian universities. These courses are offered through what is known as ELICOS or English language intensive courses for overseas students. This systemic approach to English language proficiency requirements is based on the premise that it would be difficult for students from EALD backgrounds to study at universities that strictly deliver English medium instruction (EMI). Therefore, the courses offered under the ELICOS system follow ESL or English as a second language teaching and learning practices.

There is also a plethora of evidence showing that adequate English language proficiency is essential to be successful in the Australian job market as Arkoudis et al (2009) have discussed in their report. Also see Roshid & Chowdhury, (2013) and Pandey & Pandey (2014) for some relevant discussion. Most professional registration authorities require Australian graduates from EALD backgrounds and skilled graduates from overseas to demonstrate prescribed English language proficiency levels for obtaining professional registration. Lockwood & Raquel (2019) and Manias & McNamara (2016) provide specific discussions around this.

It is in this midst and from an EALD perspective that the case of EALD Indigenous students must be viewed. The hypothesis for this research is based on this very understanding that like their fellow Australians and international counterparts from EALD backgrounds, the EALD Indigenous students would also need adequate English and academic language proficiency to successfully access education at Australian universities where English is the only medium of instruction and where English is also critical for a successful entry into the job market.

However, these Indigenous students are treated like mainstream Australian students from anglophone backgrounds. The system does not differentiate Indigenous students based on their language backgrounds, especially their EALD backgrounds. Since Australian students educated at Australian schools are presumed to have acquired English and academic language proficiencies, it is assumed that they come to University with adequate English and academic language capabilities. Subsequently the EALD Indigenous students become obscure and invisible in this midst; the system does not require them to confirm if they have adequate English proficiency to study at Australian universities.

The Hypothesis

All Indigenous students would have had access to Australian school education, but this does not change the fact that EALD Indigenous students neither speak English as their first language nor do they speak English as a main language at home. Therefore, these students could reach universities with inherent handicaps of not having appropriate control over the medium of instruction like other international students from EALD backgrounds and could have limitations with required proficiency in academic language and literacy to undertake university education. Concurring this, Stewart and Shalley (2017) had noted that inadequate English language skills prevents Indigenous students from progressing beyond Certificate III qualification in the vocational education sector. Therefore, it is hypothesised that EALD Indigenous students will have the same or similar difficulties and barriers in accessing Australian university education like other students whose primary language is not English. Since a lack of English and academic language competencies impedes their success at universities and in the job markets, it significantly disadvantages EALD Indigenous students.

To verify this hypothesis, an in-depth investigation must be conducted. Given the complexity of this context and the lack of previous similar studies, no existing, comparable or compatible research framework was readily available for this research. This necessitated the designing of a research framework inclusive of research methodologies and methods that support the proposed investigation, data collection, analysis and the findings.

As discussed earlier, this inquiry was about significantly invisible language barriers EALD Indigenous students encounter at Australian universities and is situated in a myriad of historical, socioeconomic and academic complexities. Therefore, the best way to get closer to the problem was to get closer to the Indigenous students who could be at the coalface of the barrier.

Since the research input would entirely depend on the insights and experiences of EALD Indigenous students, a grounded approach became the natural choice for this research. Since the barriers would be directly experienced by the EALD Indigenous students, a phenomenological investigation into the lived experiences of the research participants contained in a case study framework was designed. This blended investigation framework helped

the researcher cover the key bases of the problem and its context and further, a social justice perspective would be employed in the analysis of the data to ensure a human touch to the research outcomes.

The preliminary step in designing the framework of investigation for this research was to identify and confirm the key reference points. This was relatively easy, taking the experiential perspective of the EALD Indigenous university students into consideration. At the university, these students interact with three groups of facilitators namely, the academics who teach them, the Indigenous support staff, and the tutors who provide tutorial support to the students who need it.

It is understood that there are three key groups of university staff who had a direct say in the lives of EALD Indigenous students at the university. The insight of these three cohorts of university staff into the potential problems around English and academic language barriers experienced by the EALD Indigenous students under their care informed and guided this investigation.

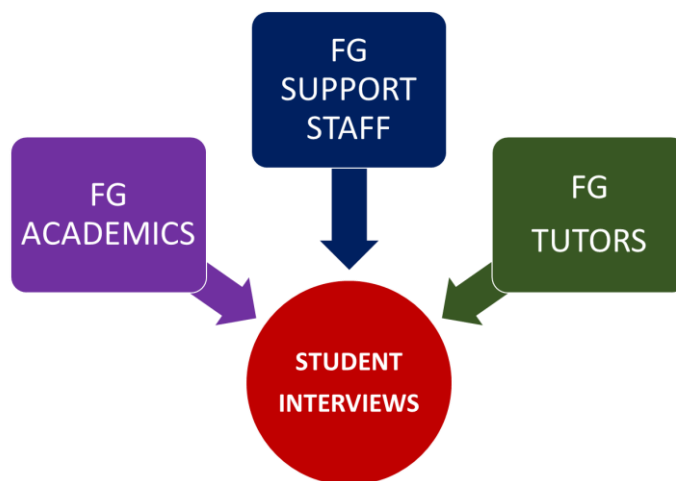

Figure 2. Focus groups enabled framing of questions to student participants

Since these groups play influential roles in the life of every Indigenous student at the University, their professional perceptions could provide valuable insight into the manifestation of potential English and academic language barriers encountered by these students. This insight would provide the investigational framework to understand the student standpoint about the language barriers they face, the implications, and the potential solutions.

The Assumable

While developing the research methodology framework, a few assumptions were made based on the researcher's academic background, professional practices and experiences as a lecturer who has taught EALD Indigenous students for many years.

Of the three key points of contact for EALD Indigenous students at the University, the most important is the interaction, face to face or online, between students and their lectures. This could also happen through the discussion boards where students interact with their lecturers and their peers. The second point of contact for these students is the Indigenous student support centre wherein the support staff and support lecturers meet students who approach them and provide support and guidance to seek solutions for both academic and personal issues. It is these support staff who help students apply for scholarships, provide support with enrolments and assist in every other important matter related to their University education. The support provided also includes provision of additional tutorial support to students facing difficulties with learning. The third and the final key cohort of contact for EALD Indigenous students are the tutors who work with them usually on a one-on-one basis. These tutors help unpack the content of the course and help the students understand the assessments and task requirements. They also assist students in finding appropriate resources and in planning and submission of assignments on time. These tutors therefore have the most authentic and intimate understanding of difficulties and barriers faced by their students.

These three groups of university staff play very distinct but vital roles in the university life, university experience and hence, success of EALD Indigenous students at Australian universities. Therefore, their

perspectives about the role played by English and academic language proficiencies in the lives of these students were used to scaffold the inquiry into student experiences and perspectives. The insights gained from separate focus groups of these three cohorts helped design the warm-up questionnaire and in-depth interview questions used with the study participants who were exclusively EALD Indigenous students.

The researcher had expectations that these groups would have a clear understanding of the role of English language in the transactions related to teaching and learning at the university, but the focus groups brought in the realisation that not everyone would have a clear concept and understanding of the challenges encountered by people at English medium universities with limited English and academic language and literacies. A reason for this apparent insufficient perception could be the fact that a vast majority of university teaching staff are not necessarily trained in ESL pedagogies and therefore may not have adequate awareness of the issues their EALD students face.

To gain an empirical insight into realistic barriers and difficulties encountered by EALD Indigenous students, it was thus necessary to ensure that these three reference groups had an opportunity to understand the context and the focus of this research in relation to the importance of English and academic language proficiencies at Australian universities. Towards this objective, the focus groups were briefed about the research and research context and a plain language statement was provided to each participant.

As per this design and as per the research terms and conditions approved by the University Human Ethics Committee at CDU, all efforts were made to ensure that the participants of the focus groups clearly understood their roles and expectations in the context of the research. In addition to providing the plain language statement and research synopsis, formal written consent was obtained from every participant.

During the focus group discussions, the participants were guided towards potential language related difficulties and struggles encountered by Indigenous students during their interactions at the University. They were encouraged to share their experiences of having to deal with situations or issues faced by Indigenous students wherein English and academic language had an important role to play. General aspects of teaching and learning, participation and assessments as well as students' ability to understand and articulate the key concepts taught in the class in prescribed academic formats like essays, presentations and reports were kept in clear focus.

The Inferable

The three focus groups provided valuable insights into English and academic language related issues face by EALD Indigenous students and the insights thus gained were used in framing the interview questions and the preliminary questionnaire for the student participants.

Due to the complex and broader context of the use of English as the sole language of teaching and assessment of EALD Indigenous students at Australian universities and given that there were almost no previous relevant investigations into this aspect, a considerable number of questions seeking clarity around the potential complexities emerged. Every one of these questions was relevant and crucial for the research and could not be excluded so, containing them within a manageable timeframe emerged as a challenge.

The solution was to separate questions that needed in-depth answers, practically creating two sets of questions. The first set with 30 questions was labelled as the Preliminary Questionnaire and included preparatory simple and basic questions about the importance of English and the day to day experiences of using it at the university. This worked as a set of warm up questions and helped orient the students towards the more focussed discussion of the role of English as a bridge or a barrier in their experience and success at the university. The second set had eight key questions for an in-depth exploration of English related student experiences of the EALD Indigenous participants.

For the first set with a wide range of short answer questions, the Likert scale was employed to seek graded answers and understand the general trends. The second set of eight questions was used to generate deeper and elaborate discussions with the EALD Indigenous students to capture their standpoint. It also sought their attitude towards the use of English at universities along with potential solutions they could suggest.

The outcome of these questionnaires was that it provided a logical and structured research instrument enabling engaging conversations with each of the eight student participants. It also helped elicit responses about an exhaustive aspect of the use of English and academic language in accessing university education, resulting in

rich data with considerable depth of student experiences and an unambiguous articulation of their standpoints. The data thus collected had provided for the key findings, but the researcher felt something further was missing. After much deliberation and debriefing with the principal supervisor, it emerged that the research would become completely meaningful only with the input from Indigenous students who in the past would have achieved significant success and achievement in the academy. Thus, the framework was improved with the inclusion of the perspectives of Indigenous leadership in Australian universities as they represent successful Indigenous students and are role models for the current and future students.

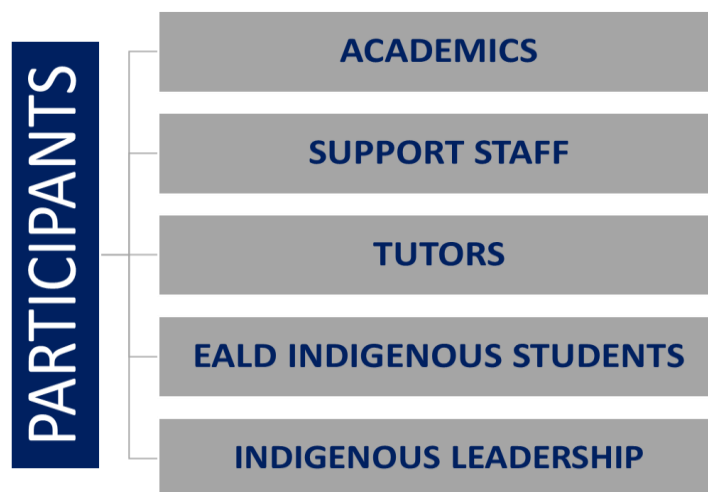

Figure 3. Key stakeholders in the research context

The researcher approached senior Indigenous academics at a few universities and three participants supported the research and agreed to contribute to the research. These Indigenous leaders were currently serving at various higher education institutions at the level of pro-vice chancellor or above. With their willing participation, the research became inclusive of the five key stakeholders integral to the context of the research, the problem and the possible solutions.

The insight from the Indigenous leadership in the academy provided both authentic and official points of view and helped the research become future-relevant as it included the aspirations articulated from a strong Indigenous standpoint.

Collectively, the focus groups provided guidance and concurrence to the preliminary questionnaire and the in-depth student interview questions. Later, the student contributions helped formulate the questions for the short interviews with Indigenous leaders in the academy.

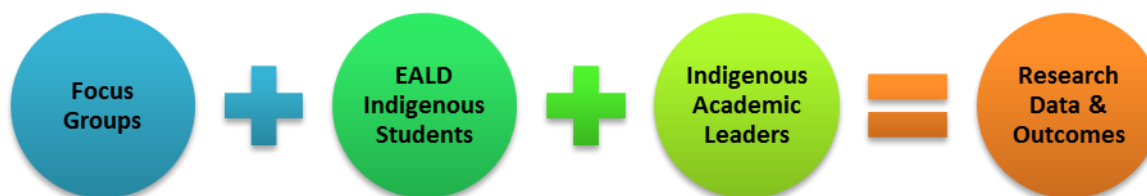

Figure 4. Research participants and data output process

Thus, the focus groups, the EALD Indigenous students and the Indigenous leaders made coherent and cohesive contributions as respective representatives of the recent past, the contemporary present and the imminent future. It also enabled a 360° analysis of the hypothesis through an elaborate investigation with an exhaustive focus on all relevant aspects, big or small.

Only a qualitative and grounded approach could have enabled the blending of phenomenology and case study methods while the critical race theory instilled the Indigenous standpoint into the research which brings out empirical insights about an extremely significant and yet, systemically invisible barrier the EALD Indigenous students could be facing at the English-only Australian universities.

References

- Arkoudis, S., Hawthorne, L., Baik, C., Hawthorne, G., O'Loughlin, K., Leach, D., & Bexley, E. (2009). *The Impact of English Language Proficiency and Workplace Readiness on the Employment Outcomes of Tertiary International Students (Full Report)*.
- Arkoudis, S., Baik, C. and Richardson, S. (2012) *English language standards in higher education: from entry to exit*, ACER Press
- Department of Education & Training (2018). *International Student Data monthly summary*. Commonwealth of Australia. Retrieved from <https://internationaleducation.gov.au/research/International-Student-Data/Documents/MONTHLY%20SUMMARIES/2019/Apr%202019%20MonthlyInfographic.pdf>
- Behrendt, L., Larkin, S., Griew, R., & Kelly, P. (2012). *Review of higher education access and outcomes for Aboriginal and Torres Strait Islander people: Final Report*. Canberra: Australian Government
- Blyth, K. 2014. "Selection Methods for Undergraduate Admissions in Australia. Does the Australian Predominate Entry Scheme the Australian Tertiary Admissions Rank (ATAR) Have a Future?" *Journal of Higher Education Policy and Management* 36 (3): 268–78.
- Cardak, B. A., and C. Ryan. 2006. *Why are High Ability Individuals from Poor Backgrounds Under-represented at University?* Melbourne: La Trobe University.
- Day D and Nolde R (2009) *Arresting the decline in Australian Indigenous representation at university; student experience as a guide*. *Equal Opportunities International* 28, 135–161.
- Day, Nakata, Nakata & Martin (2015) *Indigenous students' persistence in higher education in Australia: contextualising models of change from psychology to understand and aid students' practices at a cultural interface*, *Higher Education Research & Development*, 34:3, 501-512, DOI: 10.1080/07294360.2014.973379
- Edwards, D., & McMillian, J. (2015). *Completing university in Australia: A cohort analysis exploring equity group outcomes*. Australian Council for Educational Research, 3(3), 1–12.
- Gillan, K. P., Mellor, S., & Krakouer, J. (2017). *The Case for urgency: Advocating for Indigenous voice in education*. Australian Education Review, No. 61. Melbourne, Australia: Australian Council for Educational Research.
- Gray, J., & Beresford, Q. (2008). *A 'Formidable Challenge': Australia's Quest for Equity in Indigenous Education*. *Australian Journal of Education*, 52(2), 197–223. <https://doi.org/10.1177/000494410805200207>
- Human Rights and Equal Opportunity Commission. (2000). *Recommendations: National inquiry into rural and remote education*. Sydney, NSW: Author
- Katie Wilson & Judith Wilks (2015) *Australian Indigenous higher education: politics, policy and representation*, *Journal of Higher Education Policy and Management*, 37:6, 659-672, DOI: 10.1080/1360080X.2015.1102824
- Koramannil, G (2015), *Linguistic similarities of Aboriginal and Torres Strait Islander and international students from non-English backgrounds in higher education: implications for access and success in H. Huijser, R. Ober, S. O'Sullivan, E. McRae-Williams, R. Elvin (Eds.) Finding common ground: narratives, provocations and reflections from the 40-year celebration of Batchelor Institute (pp. 90 – 101) Batchelor Press, Batchelor NT*
- Koramannil, G. (2016). *Looking for the invisible: The case of EALD indigenous students in higher education*. *Journal of Academic Language and Learning*, 10, A87–A100. Retrieved from <http://journal.aall.org.au/index.php/jall/article/viewArticle/402>.
- Lockwood J & Raquel M (2019). *Can subject matter experts rate the English language skills of customer services representatives (CSRs) at work in Indian contact centre?*, *Language Assessment Quarterly*, 16:1, 87-104, DOI: 10.1080/15434303.2019.1604711
- Malcolm, I. G., & Rochecouste, J. (2003). *Aboriginal and Torres Strait Islander literacy in higher education: A survey of the literature*. *Literacy and Numeracy Studies*, 12(2), 15–30.
- Malcolm, I. G., Rochecouste, J., & Hayes, G. (2002). *'It's just totally different world to what you're used to': The application of Indigenous skills to university teaching and staff development*. Mount Lawley, WA: Centre for Applied Language and Literacy Research.
- Oliver, R., Rochecouste, J., Dann, T., & Grote, E. (2014). *Indigenous retention in higher education: An investigation into barriers to success and strategies to overcome them*. Bentley, WA: Curtin University.
- O'Loughlin, K (2015). *'But isn't IELTS the most trustworthy?': English language assessment for entry into higher education*. In *'International education and cultural-linguistic experiences of international students in Australia'* edited by Abe Ata and Alex Kostogriz, pages 181-194. Samford Valley Qld : Australian Academic Press, 2015
- O'Rourke, V. (2008). *Invisible fences: Perceived institutional barriers to success for indigenous university students*. Paper presented at the AARE Annual Conference, Brisbane, 2008.

- Pandey, M., & Pandey, P. (2014). Better English for better employment opportunities. *International journal of multidisciplinary approach and studies*, 1(4), 93-100.
- Roshid, M. M., & Chowdhury, R. (2013). English language proficiency and employment: A case study of Bangladeshi graduates in Australian employment market. *Online Submission*, 3(1), 68-81.
- Sharifian, F. (2006). A cultural-conceptual approach and world Englishes: The case of Aboriginal English. *World Englishes*, 25(1), 11–22.
- Siegel, J. (2010). *Second dialect acquisition*. Cambridge: University of Cambridge Press.
- Stewart, A., & Shalley, F. (2017). *A statistical overview: Aboriginal adult LLN in the Northern Territory*, . Darwin: Office of the Pro Vice Chancellor - Indigenous Leadership, Charles Darwin University
- Wilks, J., & Wilson, K. (2015). Indigenous Australia: A profile of the Aboriginal and Torres Strait Islander higher education population. *Australian Universities Review*, 57(2), 17–30.

Author Information

Ganesh Koramannil

Charles Darwin University,
Australia

Contact E-mail: ganesh.koramannil@cdu.edu.au

The influence of an In- Service Training Program on English Language Teachers' Professional Development in Palestinian Upper Primary Public Schools

Suzan QINDAH

Palestinian Ministry of Education and Higher Education

Abstract: The current study was conducted with the aim of investigating the influence of an in- service training program on English language teachers' professional development in Palestinian upper primary public schools. Thus, the current study attempted to answer the following main questions: 1- What is the influence of an in-service training program conducted by the Ministry of Education and Higher Education on English language teachers' professional development in Palestinian upper primary public schools? 2- To what extent does the in-service training program satisfy English language teachers' professional development needs in Palestinian upper primary public schools? In order for the current study to achieve its goals, a questionnaire and interview were used as instruments for the data collection. Descriptive statistics of the data was calculated using SPSS as well as thematic analysis was used to analyze the qualitative data. The results of this study revealed that the in-service training program has positive influence on English language teachers' professional development in the aspects of planning, students' engagement, teaching strategies and assessment. On the other hand, the findings of this study revealed that the program satisfies the participants' professional development need areas related to planning effectively, giving constructive feedback to learners and managing their classrooms appropriately. While conducting action research still needs more focus and effort to enable teachers practice it to improve teaching and learning process.

Keywords: Upper primary schools, Professional development, In service training program

Introduction

This chapter provides a description of the genesis of the research plan and its purpose during the doctoral Teachers' professional development is a crucial need in the 21st century to prepare students to the increasing change in this world. The students are the core of the learning process, so in this changing world, it's a need to take care of them as an investment for the future. In order to do so, the learning and teaching process should change to fit the new generation. The teaching process has mostly been teacher centered which means it is mainly controlled by the teacher and the student's role is passive (from my observations as a supervisors). In order to exchange the roles of the teacher and the student, there is a need to training programs that help teachers change their teaching practices.

Teachers should be provided with opportunities for continuous growth in order to maintain a high level of quality in education. Progress and change in our education system and the future success of students are all dependent on the teachers' professional growth and success. This can be achieved through professional development programs which are applicable, give the teachers opportunities for reflection, practical advice and involve collaboration, group discussion and sharing of knowledge between teachers.

The Palestinian Ministry of Education through the National Institute for Educational Training (NIET) has recently started a new training program that promotes the implementation of student centered learning strategies and contributes in professional development for English language teachers who teach English from 5th to 10th grade (Palestinian Ministry of Education and Higher Education, 2013). As a new program, there is a need to

assess its influence on the English language teachers' professional development and need areas satisfied during attending this program.

Research Questions:

Level 1: Participant's reactions

The first level is the most common form of professional development evaluations. It focuses on whether the participants liked the experience and if they feel their time was well spent or the material makes sense for them.

Level 2: Participants learning

This level focuses on measuring the knowledge and skills that participants gained. This can involve anything from examples of how attributes of mastery learning applied in typical classroom situations or demonstration of skills. Also oral personal reflections or portfolios that participants assemble to document their learning can be used.

Level 3: organization support and change

In this level, the focus shifts to the organization. Lack of organization support and change can prevent any professional development effort despite all the individual aspects of professional development are done right. At level 3 there is a need to focus on questions about the organization characteristics and attributes necessary for success. Encouragement at the individual level and support at all levels, sufficient resources made available including time for sharing and reflection, successes recognized and shared.

Level 4: Participants use of new knowledge and skills:

At this level the questions that can be asked could include: did the new knowledge and skills that the participants learning make a difference in their professional practice? Participants must be given enough time to adapt new ideas and practices to their settings.

Level 5: students learning outcomes

This level addresses how the professional development activity affects students and what benefit they got from it. Measures of students learning typically include cognitive indicators of students' performance and achievement, such as portfolio evaluations, grades and scores from standardized tests, also school wide indicators as enrollment in advanced classes, memberships in honor societies, participation in school- related activities, disciplinary actions. By using these five levels of information in professional development evaluations, one can prove if that professional development programs make a difference or not.

Literature Review

This section displays some previous studies and some literature views of professional development programs and their effects on teachers' practices. Also it presents some studies related to the challenges that teachers face in such programs that sometimes hinder their professional development. In other words these studies were classified into the following categories:

1-The role of professional development programs on developing teachers' practices.

The need areas of professional development First of all, the role of professional development programs on developing teachers' practices.

The first study under this category is for Arechaga (2001) in which he refers to the importance of professional development for language teachers as any other teachers who need chances to update their language and teaching skills regularly. These chances could include in-service training, and reflection. Also sharing experiences with other colleagues about a challenging issue in their work in formal or informal conversation would enhance their professional development. These activities of professional development could also contribute in correcting inappropriate applications of teachers, developing teaching competence, increasing students' achievement and improving teachers' language skills.

A key finding in Hustler et al (2003) study about Teachers' Perceptions of continuing Professional Development is that teachers viewed continuous professional development as effective when they could apply their training to classroom situation. Also they often felt motivated by continuous professional development involving the theory of teaching and teaching styles, different strategies and different ideas for using their subject knowledge and approach for teaching different topics. In addition, female teachers were more likely to feel that continuous professional development impacted on their motivation to teach more than males. In the same context, Kennedy (2005) supports the previous views when he states that participants need to have an active role in teacher training program. The programs shouldn't be determined by an expert who transfers the knowledge to the participants. He also indicates that the programs will be more successful when there is a connection between information and real teaching practices. In order to have effective professional development programs, teacher perceptions, expectations and needs have to be identified and must be taken into consideration. Clark, Mathur & Schoenfeld (2009) foster the previous views when they point out in their study that when teachers were asked about training opportunities that were important to them, they emphasized the importance of getting new information about instructional strategies and evidence based practices.

Moreover, Fields et al (2012) in their study "The science of professional Development" reported that teachers are motivated to participate in professional development in order to learn new instructional strategies and gain content knowledge.

Aminudin (2012) also points out that participants indicate that the experience they obtain from professional development affect their practice positively. All of them state that they continuously reflect on their teaching to assess its effect on their performance. By doing this they align the strategies they learn with students needs by reflecting on their responses during the lesson. Self-reflection leads teachers to be able to evaluate the effectiveness of the new teaching strategies they implement in their classrooms. They believe that professional development was necessary to keep with the changing nature of the students that they have (how they learn and their motivation to learn).

Sywelem & Witte (2013) point out in their study that almost half of the teachers believed that the in-service training activities were helpful in getting new knowledge and skills, solving the difficulties that they had in classrooms, and providing them with ideas and strategies that are helpful with classroom management. Also during the training sessions, they were given opportunities to share their ideas and experiences with peers.

Moreover, in Aminudin (2012) study the participants showed that they were motivated to improve their teaching practice. Also they are motivated to participate in professional development that is focused on the improvement of student learning.

Another study entitled Teacher perceptions of professional Development Required by Wosons in Quality Education Initiative which was conducted by Sixel (2013) showed that participants valued professional development and felt teacher choice based on student needs was important for motivation to seek out professional learning. However they were less motivated to attend required district professional development classes for new teachers. Teachers provided reasons including lack of time, redundancy of courses already taken. All participants found collaboration to be an important element of professional growth. All teachers in the study were inspired to change their classroom practice based on new knowledge from their learning or from positive results observed in their students after implementing their new knowledge and skills.

In sum, professional development programs had positive impact on teachers' practices in their classrooms. The findings of the majority of the aforementioned studies supported the effectiveness of the programs in changing teachers' practices.

Methodology

Research Design

The current study employed the mixed quantitative and qualitative – descriptive analysis methodology. A questionnaire of close ended questions was used to find out the influence of (LTD) on in-service English language teachers professional development and the satisfaction of their need areas of training. The sample consisted of 100 English language teachers who were involved in the program and teach in upper primary public schools during the scholastic year 2013 / 2014-2015. The researcher distributed 100 questionnaires but only 86 questionnaires were answered. The response rate was 86%. As for statistical procedures, mean, standard

deviation, and percentage were used to analyze the data quantitatively using SPSS. On the other hand, the researcher adapted the thematic analysis for analyzing the qualitative data. Therefore, she followed certain steps as the following. Firstly, she transcribed the sample's answers. Secondly, she coded and sorted the data according to this current study's main questions. Thirdly, she categorized the data into main themes. Finally, these themes were summarized into statements.

Population:

The population of the study consisted of 200 English language teachers who were involved in Leadership and Teacher development program conducted by the Palestinian Ministry of Education during the scholastic year 2013/2014-2015 in Ramallah, South Hebron, Jerusalem Suburbs, Salfeet, Qalqilyah, Bethlehem and Hebron.

Sample

Non-random purposeful sample was chosen in this study from Ramallah, Jerusalem Suburbs, South Hebron, Salfeet and Qalqilya. The following Table (3.1) included the characteristics of the current sample for this study:

Table 3.1. Characteristics of the Sample

Gender		
Variable	No.	Percentage
Male	26	30 %
Female	60	69.9 %
Total	86	100 %
Age		
Less than 25	3	3.5 %
25 – 35	38	44.2 %
35 – 45	36	41.9 %
Above 45	9	10.5 %
Total	86	100 %
Academic qualification		
Diploma	0	
B . A	77	89.5 %
M.A or higher	9	10.5 %
Total	86	100 %
Experience		
1 – 2 years	2	2.5 %
3 -5 years	11	12.8 %
6 – 15 years	59	68.6 %
Above 15	14	16.3 %
Total	86	100 %

Instrumentation

Questionnaire

In order for the current study to achieve its goals, a questionnaire was used as a tool to examine the influence of LTD program on English language teachers professional development and the satisfaction of their need areas of training. It consisted of five domains; Likert scale of four choices is used. The scale is, 4= strongly agree 3= agree 2= disagree 1= strongly disagree

The questionnaire is developed based on Palestinian teachers' competences (Ministry of Education, 2013); it was developed by (the Research and Evaluation Section at the National Institute for Educational Training (NIET), 2015). The questionnaire consisted of 53 items, divided into two main parts. In its first part, the participants were required to fill in information about their demographic variables. These variables included gender, age and the length of their educational profession experience. The second part reflected the influence of the program on English language teachers' professional development on their planning ability, students' engagement, teaching strategies and their ability to assess their students. The third section consisted of eleven items and referred to the need areas satisfied during participating in LTD program.

Interviews

Semi structured interviews were conducted with 10 teachers who participated in the program to get more information that contribute to answer the research questions. The questions of the interview were formed by the researcher after reviewing previous studies. The interview consisted of five questions answered individually. The participants' responses on the questions were recorded after taking permission from them to do that.

Validity and Reliability of the Instruments

Validity

Face validity: it was verified by the researcher.

Content validity: For assessing the instruments' content validity, the questionnaire was reviewed by a university instructor and three trainers from the National Institute for Educational Training. They approved its validity and appropriateness. The same is done with the interview questions.

Reliability

The questionnaire's reliability was determined through using the Cronbach Alpha formula as it could be found in the following table for the closed statements.

Cronbach's Alpha	N of items
.921	60

As appeared in the above table, the instrument was reliable since the variables of Cronbach's Alpha ranged between +1 and -1. On the other hand, the respondents' validity was used to determine the interview questions' reliability.

Statistical Procedures

The results of the questionnaires were analyzed using the following methods.

Means were classified as followed in the first, second, third, fourth, and fifth sections: Mean scores that ranged between 2.4 and 2.79 were considered as "low", mean scores that ranged between 2.8 and 3.19 were regarded as "medium", while mean scores that ranged between 3.20 and 4.0 were regarded as "high". These scores of means are used for the closed statements.

Thematic analysis was used to analyze the interview questions - Each teacher was given a symbol. The symbols ranged from T1 for the first teacher, T 2 for the second teacher, T 3 for the third teacher until T 10 for the tenth teacher. Firstly, the sample's answers of the interview questions were transcribed. Secondly, the data was coded and sorted according to the study's main questions. Thirdly, the data was categorized into main themes. Finally, these themes were summarized into statements.

Results and Discussion

In this chapter the researcher presented the results for each question of the research questions:

Question No. 1: what is the influence of an in-service training program conducted by the Ministry of Education and Higher Education on English Language teacher's professional development?

Table 4.1. Means for of the influence of Leadership and Teacher Development program on their ability to plan

No.	As a result of participating in LTD program, I am able to	Minimum	Maximum	Mean	Standard deviation
1	Plan classroom activities that are learner centered.	3	4	3.26	.445
2	Align intended outcomes with the needs and abilities of the learners.	2	4	3.10	.532
3	Plan and implement projects based on the integrated curricula.	1	4	3.17	.538
4	Plan activities that tap various types of intelligences.	2	4	3.39	.558
5	Design definite learning outcomes that fit the general outcomes of the primary stage curricula.	2	4	3.16	.481
6	Reflect more on how my class is progressing and adjust my teaching to improve student performance.	2	4	3.23	.662
7	Design a unit plan for teaching English based on "backward design" (big ideas, essential question, concepts, skills.....)	2	4	3.46	.546
8	build daily and terminal plans that fit different learning styles	3	4	3.34	.479
9	Take learners' misconceptions of content into consideration while planning my lessons.	2	4	3.19	.480

The above table presents the results that show the influence of LTD program on English language teachers' ability to plan their lessons. As displayed in the previous table, the highest mean scores were reported for the following items (7, 4, 8 & 6). The reported means were (3.46, 3.39, 3.34& 3.23) respectively. For example, item (7) suggests that LTD program helped teachers to develop their ability of planning units based on backward design. Item (4) indicates that LTD program helped teachers to plan activities that tap various types of intelligences. In addition, item (8) suggests that (LTD) program helped teachers build daily and terminal plans that fit different learning styles. Moreover, item (6) shows that (LTD) program helped English language teachers reflect more on how their class is progressing and adjust their teaching to improve students' performance.

Table 4.2. Shows means for the influence of (LTD) program on teachers' ability to engage their students: **students' engagement**

		Minimum	Maximum	Mean	St. d
10	Enhance learners' participation in different classroom activities.	3	4	3.44	.499
11	Engage learners in developing various learning sources.	2	4	3.29	.550
12	Make my teaching meaningful by connecting new experiences to what learners' already know.	2	4	3.38	.635
13	Involve learners in developing classroom and school rules.	2	4	3.43	.584
14	Create learning environment that encourages learners to learn by doing.	2	4	3.27	.679
15	Create equal learning opportunities for all students.	2	4	3.27	.545
16	Create a peaceful and healthy environment that encourages learners in the learning process.	2	4	3.36	.506
17	Create an alternative learning environment that promotes learners' creativity and critical thinking.	2	4	3.17	.636
18	Employ 21 st century skills in a way that enhances integration.	2	4	3.38	.535
19	Engage learners in tasks that enhance their confidence, responsibility and learning quality.	2	4	3.32	.495

The above table presents results pertaining to the example how (LTD) program affected teachers ability to enhance their students' engagement. As displayed in this table, the reported mean scores for 8 items were ranged

between 3.27 and 3.44 which were considered “high” and just one mean score that is reported as “medium”. The least mean score was 3.17 and was reported for item (17) which suggests that LTD program helped English language teachers create an alternative learning environment that promotes learners’ creativity and critical thinking. The highest mean score was reported for item (10) which suggests that LTD program fostered teachers’ ability to enhance learners’ participation in different activities.

Table 4.3. Means for the influence of LTD program on teaching strategies

No.	Teaching strategies	Minimum	Maximum	Mean	Standard deviation
20	Implement strategies that create and enhance peaceful environment in my school.	2	4	3.24	.458
21	Conduct enrichment activities to the curriculum that enhance cooperative learning between learners.	2	4	3.30	.486
22	Implement information and communication technology in teaching and learning process.	2	4	3.30	.510
23	Use community sources as trips, visits and human resources in improving learning process.	2	4	3.10	.719
24	Improve creative learning abilities and skills by using different teaching and learning sources.	1	4	3.23	.607
25	Work with other colleagues to design an actual school improvement project that requires building internal and external partnership between the school and the larger community.	2	4	3.04	.572
26	Conduct action researches to improve teaching and learning process.	2	4	2.98	.583
427	Integrate the four skills (reading, writing, listening and speaking) while teaching.	2	4	3.44	.522
28	Implement some tasks that encourage my students to search and learn autonomously.	2	4	3.22	.570

The above table presents results pertaining to the influence of LTD program on teaching strategies. As displayed in this table, most mean scores are ranged between 3.44 and 3.04 which were regarded “high”. The highest mean score was reported for item (27) which suggests that LTD program enhance teachers’ ability to integrate the four skills (reading, writing, listening and speaking) while teaching. On the other hand, the lowest mean score was reported for item (26), the mean score was (2.98) which is regarded as “medium”. This item suggests that LTD program helped English language teachers to conduct action researches to improve teaching and learning process.

Table 4.4. Means for the influence of LTD program on teachers’ ability to assess their students

Assessment: As a result of participating in this program I am able to					
		Minimum	Maximum	Mean	Standard deviation
29	Employ the results of assessment to improve the quality of teaching and learning.	2	4	3.25	.557
30	Design individual plans to improve teaching based on assessment process.	2	4	3.29	.550
31	Use the results of self-reflection to improve teaching and learning process.	2	4	3.17	.563
32	Design authentic assessment tasks.	1	4	3.19	.570

33	Use standards for assessment.	1	4	3.11	.621
34	Design rubrics for assessing tasks.	1	4	3.19	.610
35	Provide learners with feedback on their work.	2	4	3.36	.506
36	Assess myself for professional development purposes.	2	4	3.37	.509
37	Document evaluation results to use it in monitoring learners' progress.	2	4	3.17	.465
38	Build different assessment tools that fit individual differences between learners.	2	4	3.23	.479
39	Encourage students to use self-assessment.	2	3	3.65	.334
40	Keep a portfolio for all my activities and documents to monitor my professional development.	2	4	3.49	.569
41	Use portfolio to assess and monitor learners work.	2	4	3.35	.591
42	Design different assessment tools (tests, performance tasks, projects.....)	2	4	3.33	.590

The above table presents results pertaining to teachers' ability to assess themselves and their students. As presented in this table, most mean scores were ranged between 3.49 and 3.23 which were regarded "high". The highest mean score was reported for item (40), the mean score for this item indicates that LTD program helped teachers to keep a portfolio for all their activities and documents to monitor their professional development. The lowest mean score was reported for item (33) and it was 3.11 which was regarded "medium". This item suggests that LTD program helped teachers use standards for assessment.

Table 4.5. Means for the influence of LTD program on English language teachers practices

Domain	N	Minimum	Maximum	Mean	Standard deviation
The influence of LTD on planning	86	2.22	4.00	3.26	.29574
The influence of LTD on students engagement	86	3.00	4.00	3.26	.44522
The influence of LTD on teaching strategies	86	2.67	4.00	3.20	.34578
The influence of LTD on assessment	86	2.60	4.00	3.29	.38006
Total	86	2.70	3.90	3.23	.25360

The above table presents results of the influence of LTD program on English language teachers' professional development. As presented in this table the mean score for all items under this domain was 3.23 which is considered "high". The highest mean score was reported for the impact of LTD program on assessment; the score reported was 3.29 which considered "high".

The following themes presented results pertaining to the examples of specific aspects of the English language teachers' perceptions of the effectiveness of Leadership and Teacher Development (LTD) program. Five themes were concluded from interview questions related to this aspect. These were: "motivation to teach and learn", the effect of the program on classroom instruction," "learners involvement and motivation", school improved generally," and working as a team with other teachers."

The first theme was "motivation to teach and learn". All the tenth participants in the interview assure that their motivation to teach increased after applying the new strategies they learnt from the program. For instance, **T3** stated the following "This program gives me the opportunity to improve and think of what I'm doing, so I became more active and want to learn more.

"The effect of the program on classroom instruction" was the second theme. The participants' answers showed how LTD program made them to be aware of their students' individual differences, multiple intelligences and

learning styles. For example, **T1**'s answer was *"Yes, of course, it enhanced my awareness of my students' individual differences and how to deal with them. Moreover, T3 said "It gives me new methods and techniques, opportunity to exchange experience with colleagues."*

The third theme was "learner involvement and motivation." The answers revealed that the teachers discovered some of their students for the first time while applying the new strategies. For instance, **T2** reported the following *"Students who never participated in the class start to take part and do something."*

"School improved generally" was the fourth theme. **T2** pointed out *"We conduct projects together to let students apply what they learn."* Also **T4** stated *"I feel that a change revolution started in my school, in teaching, in working together to improve the school environment."* The fifth theme was "working as a team with other teachers." Participants indicated in their answers that they work together to conduct projects and exchange experience. For example, **T1** pointed out *"We've started to cooperate together more than before to conduct projects, give feedback for each other."*

Based on the results, the different aspects in which LTD program affected English language teachers professional development majorly centralized on planning, student engagement, teaching strategies and assessment. First of all, the teachers showed that LTD program affected their planning ability positively. It showed that LTD program helped teachers develop their ability of planning their lessons; also it helped them plan activities that tap various types of intelligences. In addition, it helped them to reflect more on how their classes are progressing and adjust their teaching to improve students' performance.

Teachers chose those aspects because they used to write traditional, daily, and terminal plans as a routine for the supervision of the supervisor and the school principal. During this program, participants were required to plan activities which were learner centered and tap their students multiple intelligences and learning styles. Moreover, teachers were trained to write their reflections on their practices which enable them to think deeply and assess their performance to assign the strengths and weaknesses in their practices. Since teachers have multilevel students in their crowded classes, they need to plan different activities that suit their students' level and interest in order to attract and involve them in the learning process. This result marked agreement with Archibald et al (2002) study in which they indicate that effective professional development is a crucial issue in today's context to accomplish today's students' achievement goals. Also this finding is matched with Desimone (2011) study which shows that the instructional change that teachers introduce to the classroom boost their students' learning. In relation to reflection, this finding corresponds with Aminudin (2012), Tillema (2004) studies in which they point out that all participants reflect on their teaching to assess its effect on their performance. By doing this they align the strategies they learn with students' needs by reflecting on their responses during the lesson.

Secondly, finding related to English language teachers' ability to engage their students in learning process, these indicate that LTD program affected English language teachers positively in enhancing learners participation in different classroom activities. As part of their training modules, English language teachers have started to apply learner centered activities in their classrooms by giving their students different roles in the class to act, play, present. As teachers they became facilitators and guides for their students during the learning process and give help when necessary.

Furthermore, the results show that teachers scored the item related to creating an alternative learning environment that promotes learners' creativity and critical thinking the lowest which indicates that they are trying to do that, but still they need more time and effort also support from others to succeed in doing that. This finding is opposed to Eksi (2010) which indicates that most teachers think that it is necessary to be familiar with new trends such as critical thinking.

As for the results related to the influence of LTD program on teaching strategies, teachers indicate that this program enhance their ability to integrate the four skills (reading, writing, listening and speaking) while teaching. English language teachers used to teach the four skills separately and sometimes they neglect teaching some skills like listening and speaking. This program sheds the light on the importance of teaching and integrating the whole skills together to enable the learners to communicate appropriately with the language. Another obvious finding related to this domain was that the program affected teachers' ability positively in conducting enrichment activities to the curriculum that enhance cooperative learning between learners. Teachers try to experiment the new strategies that they become familiar with during the program, they also encourage their students to work and cooperate together in group and pair work since they are moving toward student centered learning.

This finding is consistent with Eksi (2010), Sweylem & Witte (2013) in which their results show that teachers are enthusiastic about freedom to test new ideas or new techniques. Also in service training activities were helpful in getting new knowledge and skills, solving the difficulties they had in classrooms. The results for this domain also revealed that teachers did not conduct action research to improve teaching and learning process as frequently as other strategies. Teachers were trained to conduct action research in the first module of their training, but still they are not convinced to use it to improve their classroom practices. Action research was presented with other topics in the module such as teaching philosophy, the importance of professional development and portfolio. Teachers need time to get used to conduct action research.

The findings of the first domain under the category, the influence of LTD program on teachers’ professional development, revealed that this program has positive influence on English language teachers’ professional development. Also it affected their ways of assessing their students. This program gave the teachers an opportunity to exchange experience with other colleagues inside and outside the school and in the training sessions. Also this is matched with Arechaga (2001) which points out that sharing experiences with other colleagues about a challenging issue in their work in formal or informal conversation would enhance their professional development.

Question No. 2: To what extent did the in-service training program satisfy English language teachers professional development needs in Palestinian upper primary public schools?

Table 4.7.Means for the participants’ professional development need areas that satisfied by LTD program

In brief, participating in this program helped me satisfied the following professional needs:				
	Minimum	Maximum	Mean	Standard deviation
Planning my lessons effectively.	3	4	3.47	.502
Managing my classroom appropriately.	2	4	3.43	.521
Identifying learners’ characteristics.	2	4	3.36	.529
Giving constructive feedback to learners.	3	4	3.63	.168
Differentiating my instruction.	2	4	3.16	.481
Differentiating assessment tools for learners.	2	4	3.11	.540
Conducting classroom action researches.	1	4	2.96	.818
Creating strategies for teaching English (games, drama, songs, storytelling.....)	2	4	3.30	.614
Integrating technology in teaching English language.	1	4	3.31	.579
increasing students’ motivation	1	4	3.36	.594

The above table presents the results pertaining to participants’ professional development need areas that were satisfied by LTD program. As displayed in this table, the highest mean scores were reported for items (57, 54, 55), mean scores reported were (3.63, 3.47, 3.43) respectively. For example, item (57) suggests that LTD program satisfy participants’ professional development need areas in giving constructive feedback to learners, the mean score reported for this item was 3.63 which was considered “high”. On the other hand, the lowest mean score was reported for item (60) which indicates that LTD program satisfy teachers’ need in conducting classroom action researches, the mean score reported for this item was 2.96 which is regarded “medium”. The total means score that was reported for this domain “professional need areas that were satisfied by LTD program were 3.31 which was considered “high”.

The findings related to the professional development need areas that LTD program satisfy revealed that the program satisfy English language teachers needs in giving constructive feedback to learners, planning their lessons effectively and managing their classrooms appropriately. These findings are opposed to Sywelem and Witte (2013) findings which revealed in Saudi elementary schools continuous professional development activities do not take into consideration teachers’ existing knowledge, experience and needs. On the other hand, teachers’ degree of need was the lowest in conducting action researches which means that the program did not satisfy the teachers need in this aspect.

The themes concluded from the interview related to professional development need areas that were satisfied during the program were as follow: “providing teachers with new strategies” and “opportunity to learn from each other”. Participants showed that this program give them new techniques in teaching English as a foreign language and also new ways and tools to assess their students. In addition, it provided them with the opportunity to learn from each other and exchange their experience. This is matched with (Laster 2003) in which he pointed

out that as innovative teachers share their best practice ideas, colleagues also benefit professionally from their expertise.

Based on the results of the study, a number of recommendations could be passed to designers of the program and also to the Palestinian Ministry of Education:

- 1- More time and effort should be given for training teachers how to conduct an action research to improve their practices in the classroom.
- 2- To generate this program to more English language teachers to enhance their professional development practices.
- 3- **Recommendations for Further Research**

This study highlights some issues related to influence of Leadership and Teacher Development program on English language teachers' professional development. It also shed the light on the need areas that were satisfied during the program. As a part of this study, the following areas need further research:

- It is suggested to carry out a comparative research to compare between the effectiveness of LTD program and other professional development programs.
- It is suggested to carry out another research to investigate the effects of the program on students' achievement.
- Further research should include the effects of English language teachers' demographic variables such as age, gender and years of teaching experience on evaluating the effectiveness of LTD program.

References

- Aminudin, Nurul Aini (2012). Teachers' perceptions of the impact of professional development on teaching practice: the case of one primary school. Master thesis, Unitec Institute of Technology. New Zealand. Retrieved on 16th May 2015 from http://unitec.researchbank.ac.nz/bitstream/handle/10652/2013/Nurul%20Aini%20Aminudin_MEdL%26M.pdf?sequence=1
- Archibald, Sarah, Fremanich, Marck, Gallagher, Alix H. & Odden, Allan (summer, 2002). A cost framework for professional development. *Journal of Education Finance* (28), 51-74
Retrieved on May 14th 2015 from <http://www.jstor.org/stable/40704157>
- Arechaga, Graciela Miller (August, 2001). Teacher development: Awareness, reflection and sharing. *ELT Newsletter*. The weekly column, Article 69.
Retrieved on 10th May 2015 from <http://www.eltnewsletter.com/back/August2001/art692001.htm>
- Aydin, Yesim Capa, Eksi, Gul (2013). English instructors' professional development need areas and predictions of professional development needs. *Procedia- Social and Behavioral Sciences* 70, 675-685
Retrieved on May 14th 2015 from <http://www.sciencedirect.com/science/article/pii/S1877042813001092>
- Clark, Heather Griller, Mathur, Sarup R., Schoenfeld, Naomi A. (June 2009). Professional development: A capacity Building Model for Juvenile Correctional education systems. *The Journal of Correctional Education*, 60 (2), 164-184. Arizona State University.
Retrieved on April 23rd 2015 from <http://www.jstor.org/discover/10.2307/23282723?uid=3738872&uid=2129&uid=2&uid=70&uid=4&sid=21104102081707>
- Desimone, Laura (2011). A primer on Effective Professional Development. *The Phi Delta Kappan* 92 (6), 68-71.
Retrieved on March 23rd 2015 from <http://www.jstor.org/stable/25822820>
- Eksi, Gul (2010). An assessment of the professional Development Needs of English Language Instructors working at a State University. Master Thesis, Middle East Technical University. Turkey.
Retrieved on 25th 2015 from <http://etd.lib.metu.edu.tr/upload/12612808/index.pdf>
- Fields, Erica, Levy, Abigail, Karelitz, Tzur M., Gudapakkam, Audrey and Jablonski, Erica (2012). The Science of Professional Development. *The Phi Delta Kappan*, 93 (8), 44 – 46.
Retrieved on April 4th 2015 from <http://www.jstor.org/stable/23210372>
- Guskey, T.R (2002). Professional development and teacher change. *Teachers and teaching, Theory and practice* 8 (3/4), 381 - 391

Retrieved on 21/ 3/ 2015 from

http://class.anhoes.ntpc.edu.tw/happy/wenwen/files_dl/Guskey2002%20Professional%20Development%20and%20Teacher%20Change.pdf

Hismanoglu, Murat & Hismanoglu, Sibel (2010). English Language Teachers' Perceptions of Educational Supervision in Relation to other professional Development: A case study of Northern Cyprus. *Novitas-Royal (Research on Youth and Language_4_1)*, 16-34.

Retrieved on April 2nd 2015 from

http://www.novitasroyal.org/Vol_4_1/hismanoglu.pdf

Kennedy, A (2005). Models of continuing professional development: A framework for analysis. *Journal of In-service Education* 31 (2), 235-250

Retrieved on May 10th from

<http://www.tandfonline.com/doi/abs/10.1080/13674580500200277>

Lester, Julie (2003). Planning Effective Secondary Professional Development programs. *American Secondary Education*. 32 (1), 49-61.

Retrieved on March 22nd 2015 from

<http://www.jstor.org/paginfo/about/policiesterms.jsp>

Ministry of Education and Higher Education (2013). Leadership and Teacher Development (LTD) Program. Palestine.

<http://www.jstor.org/stable/4445649>

Ministry of Education and Higher Education-Palestine (2012). Monitoring and Evaluation System of the Strategic Plan for Professional Development 2008-2012. Monitoring and Evaluation Report 2012.

Retrieved on 25 August 2016 from

<http://www.moehe.gov.ps/%D8%AE%>

Sixel, Debarah Marie (2013). Teachers' perceptions of professional Development Required by Wisconsin Quality Educator Initiative PI 34. Dissertation. The University of Wisconsin- Millauke.

Retrieved on April 2nd 2015 from

<http://dc.uwm.edu/cgi/viewcontent.cgi?article=1163&context=etd>

Sywelem, Mohammad& Witte, James (2013). Continuing Professional Development: Perceptions of Elementary School Teachers in Saudi Arabia. *Journal of Modern Education Review* 3 (12), 881-898.

Retrieved on 20 / 5 / 2015 from

https://www.researchgate.net/profile/Mohamed_M_Ghoneim_Sywelem/publication/273123485_

Tessema, Amdeberhan (2012). Teacher Educators' professional Development towards Educational Research in Student- Centered Instruction Support by Dynamic Mathematics Software. Master Thesis. University of Amsterdam, the Netherlands.

Retrieved on 20/ 3/ 2015

<http://www.science.uva.nl/onderwijs/thesis/centraal/files/f1699971723.pdf>

Tillema, Harm H. (2004). Embedding and Immersion as key strategies in learning to teach. In Henny P.A. Boshuizen, , Rainer Bromme, Hans Gruber (Eds), *Professional learning gaps and transitions on the way from novice to expert* (pp.141-156). Netherlands: Kluwer Academic Publisher.

Author Information

Suzan Qindah

National Institute For Educational Training/
Ministry of Education & Higher Education,
Palestine

Contact E-mail: suzanadnan@gmail.com

The Evaluation of the Relationship between the Academic Achievement of Social Studies Teacher Candidates and Their Attitudes towards Environment

Ozkan AKMAN
Gaziantep University

Mustafa Murat CAY
Gaziantep University

Abstract: The century that we left behind took its place in the history books as a century of urbanization, industrialization, information and development, where there were many discoveries and breakthroughs in science and technology, and many global changes in human history. In order to provide an original environmental education, firstly educators who can give this education should be trained. The training of teachers who will train generations to decide on the environment in the future constitutes one of the most important stages of environmental education which is expected to be given to all segments of the society for life. Therefore, the relationship between education and the environmental problems in the last quarter of the century will be examined again; the sensitivity of teachers, schools, curriculums to environmental awareness and the ability to raise individuals with high environmental awareness has been questioned again. The aim of this study is; The aim of the course is to determine the level of relationship between the academic achievement of the social studies teacher candidates and their attitudes towards the environment. In this study, qualitative research methods, relational scanning technique has benefited from. The study group of research Nizip, Gaziantep University, Faculty of education social studies were conducted with students who studied at 12. Data from semi-structured interview were analyzed according to the responses given from the form. According to the results, it is observed that the sensitivity towards the environment is higher in female students with higher academic achievement, and that teacher candidates' attitudes towards environmental behavior and environment and their attitudes towards environment are above medium level and positive.

Keywords: Teacher candidates, Attitude, Environmental education

Introduction

The roots of environmental education are based on nature and natural resource conservation education. However, as environmental movement is different from nature conservation activities, environmental education is different from nature and natural resources conservation education. Environmental education is focused on protecting and improving the entire environment, including biosphere, biomes and ecosystems, in addition to developing and conserving natural resources such as soil, water and forest. Ecology has been an important cornerstone of environmental education in terms of explaining how ecosystems operate. Over time, environmental education has gone beyond informing the world citizens about the environment and making them participants with environmental management skills and hearts (Peyton, Campa and Winterstein, 1995).

According to the findings of international studies on environmental education, the level of education in which individuals can receive environmental education in the most efficient way is secondary education. The most important factor in achieving the objectives of environmental education is the teacher and naturally secondary education teachers should be trained to provide environmental education.

Although a wide variety of solutions to environmental problems are proposed, it is most notable that these problems are prevented before they emerge at the source. It is accepted by many circles that education is the most important factor for this. For this reason, many organizations such as UNESCO, UNEP, Ministries of Environment, Universities, Municipalities and some NGOs are carrying out studies based on environmental education (Peyton, Campa and Winterstein, 1995).

The basis of environmental education is to protect nature and natural resources. In addition to providing information, environmental education should also influence human behavior. The main objective of environmental education is to gain positive and lasting behavioral changes and to ensure the active participation of individuals in solving problems. Although there are various opinions that the level of education in which children can receive environmental education in the most efficient manner is secondary education, positive attitudes and behaviors towards the environment have been made in a systematic and regular way in pre-primary and primary education period since many families in our country do not have enough consciousness to inform and educate their children about the environment. improved. In the studies conducted to contribute to environmental education, it is stated that the environmental issues discussed in Preschool, Primary and Secondary education programs in our country are not sufficient in terms of developing environmental awareness (Hungerford, Volk and Ramsey, 1989).

Individuals who are effective in the emergence of environmental problems should also be brought to the awareness of their responsibilities in the elimination of these problems. This can only be achieved through effective environmental education (Altın, Bacanlı ve Yıldız, 2002; Soran, 2000; Özer, 1991). However, in the studies conducted in this field, misconceptions detected in all levels of education reveal that environmental education is not effective at the desired level and emphasizes that the course should be saved from memorization (Webb and Boltt, 1990; Özkan, Tekkaya and Geban, 2001; Haktanır and Çabuk, 2000; Yılmaz, Morgil, Aktuğ and Göbekli 2002). This suggests that teachers who will provide environmental education should have good education at higher education level. However, sensitive and conscious teachers can give the students the necessary awareness and responsibility about the environment. However, to increase the effectiveness of the course; it becomes necessary to use teaching approaches that activate the student, free him from the portrayal of knowledge and improve his brain power.

As a result of the fact that environmental pollution experienced in the end of the 20th century knew no limits, on the other hand, the rapid development of communication tools, the event being heard at one end of the world and the other end in a short time is one of the reasons for the creation of an important environmental sensitivity all over the world (Geray, 1992). In order to educate environmentally sensitive individuals, an education system that actively participates in environmental issues and reacts to the negative effects should be developed. Consideration should be given to raising individuals with respect for each other and with humanitarian values. Thus, all elements of the environment to be known as full and correct and environmental protection can be provided (Glover and Deckert, 1998). Environmental sensitivity can be defined as willingness to take positive initiatives against environmental problems (Çalıklan, 2002). In this case, it is possible to improve the environmental sensitivity of individuals by raising the awareness level. Increasing the level of consciousness may be provided by environmental education which will be given in accordance with each level (Türksoy, 1991; Çelikkıran 1997; Kapyła and Wahlstrom, 2000). It can be said that individuals' behavior towards the environment is a reflection of the environmental sensitivity of each other. In this context, environmental sensitivity of individuals can be determined by considering green area problems, environmental pollution, population growth and ecological balance. The aim of this study is to determine the level of relationship between the academic achievement of social studies teacher candidates and their attitudes towards the environment. For this purpose, the answers to the following sub-problems were sought.

1. Is there a relationship between the academic achievement of social studies teacher candidates and their interest towards the environment?
2. Are there any service practices you have made for the environment in your 4-year university life?
3. Have you been involved in environmental research activities?
4. What can we do for a better environment?

Method

Semi-structured interview technique, one of the qualitative research methods, was used to reveal the current situation. It is a descriptive study.

Working Group

The study group of the research is limited to the social studies teacher candidates studying in the 4th grade of Gaziantep University Nizip Education Faculty. 20 of the teacher candidates are female and 17 of them are male students.

Data Collection Tools

The data of the research;

- a. 37 semi-structured interview forms applied to prospective teachers.
- b. Academic achievement averages of prospective teachers.

Analysis of Data

The data obtained from the interview form were analyzed descriptively. The aim of the descriptive analysis approach is to present the obtained data to the reader in an edited and interpreted state (Şimşek and Yıldırım, 2011).

Results

Findings for the First Sub-Problem

It was observed that male teacher candidates with high academic achievement had higher attitudes towards environment than female teacher candidates with high academic level. However, it was observed that both male and female teacher candidates had higher environmental attitudes.

Findings for the Second Sub-Problem

Are there any service applications you have made for the environment in your 4-year university life? They stated that they were engaged in activities related to air, sound and soil pollution in the courses of community service practices and social sensitivity projects in the faculty of education to which they were connected. Within the scope of the course, they contacted the related organizations and stated that they are doing activities to collect noise from the traffic, planting trees and waste in the environment.

Findings for the Third Sub-Problem

Do you carry out environmental research activities? Most of the pre-service teachers stated that they participated in scientific studies such as panels, conferences, etc. in cat faculties and other faculties. Some of the teacher candidates stated that they participated in voluntary organizations working on environmental issues.

Findings of the Fourth Sub-Problem

What can we do for a better environment? They have stated that they have not received enough environmental education in the educational institutions they have received so far. It can be said that a significant number of students stated that they did not receive sufficient education to become conscious. For this, they stated that in every program determined by YÖK, there should be environmental courses.

Conclusion and Recommendations

In general, according to the findings, it was seen that male teacher candidates were more sensitive to environment than female teacher candidates. Pre-service teachers stated that they do environmental studies in challenging courses in the faculty they are studying during their university education. They also stated that they

participated in scientific activities related to the environment. Finally, they stated that YÖK's exchange definition should be rearranged for more efficient regulation of environmental awareness.

In the light of the results obtained, female students should be encouraged to participate in voluntary environmental studies, the number of activities such as panel conferences should be increased and more effective people should be invited for the speaker, afforestation of the faculty should be realized with the participation of all students and faculty members.

References

- Altın, M., Bacanlı, H. ve Yıldız, K. (2002). *Biyoloji Öğretmeni Adaylarının Çevreye Yönelik Tutumları*. V. Ulusal Fen Bilimleri ve Matematik Kongresinde sunulmuş Bildiri, ODTÜ, Ankara.
- Çalışkan, M. (2002). Yetişkinlerde çevre duyarlılığını etkileyen etmenler. *Unpublished Masters Thesis*. Ankara Üniversitesi Eğitim Bilimleri Enstitüsü, Ankara.
- Çelikkıran, A. (1997). Çevre sorunları ve eğitim. *Yayımlanmamış Yüksek Lisans Tezi* Ankara Üniversitesi Sosyal Bilimler Enstitüsü, Ankara.
- Geray, C. (1992). Çevre için eğitim. (Der. Keleş, R.). *İnsan çevre toplum*. İstanbul: İmge Kitabevi.
- Glover, J. M., & Deckert, L. (1998). What works in environmental education. *Parks and Recreation*, 33(11), 30-39.
- Haktanır, G. ve Çabuk, B. (2000). *Okulöncesi Dönemindeki Çocukların Çevre Algıları*. IV. Fen Bilimleri Eğitimi Kongresi Bildiri Kitabı, 76-82. Hacettepe, Ankara
- Hungerford, H. R., Volk, T. L., & Ramsey, J. M. (1989). Prototype environmental education curriculum for the middle school. In *Environmental Education Series* (No. 29). UNESCO. Division of Science Technical and Vocational Education.
- Kapyla, D., & Wahlstrom, J. (2000). Evaluating the effectiveness of residential environmental education program. *The Journal of Environmental Education*, 31(2), 31-37.
- Özer, U. (1991). *Çevre eğitimi*. Türkiye'de Çevre Kirlenmesi Öncelikleri Sempozyumu Kitabı, 21-22. İstanbul.
- Özkan, Ö., Tekkaya, C. ve Geban, Ö. (2001). *Ekoloji Konularındaki Kavram Yanılgılarının Kavramsal Değişim Metinleri İle Giderilmesi*. Yeni Bin Yılın Başında Fen Bilimleri Eğitimi Sempozyumu Bildiriler Kitabı, 191-194. İstanbul.
- Peyton, B., Campa, H., & Winterstein, S. R. (1995). *Biological diversity for secondary education* (No. 504.7 PEY).
- Soran, H., Morgil, İ., Alev, E. ve Işık, S. (2000). Biyoloji Öğrencilerinin Çevre Konularına Olan İlgilerinin Araştırılması Ve Kimya Öğrencileri İle Karşılaştırılması. *H. Ü. Eğitim Fakültesi Dergisi*, 18, 128-139.
- Şimşek, H., & Yıldırım, A. (2011). Sosyal bilimlerde nitel araştırma yöntemleri. *Ankara: Seçkin Yayıncılık*.
- Türksoy, Ö. (1991). Çocuk ve çevre duyarlılığı eğitimi. *Yaşadıkça Eğitim Dergisi*.(19), 22-31.
- Webb, P. and Bolt, G. (1990). Food Chain to Food Web: A Natural Progression?. *Journal of Biological Education*, 24(3), 187-191.
- Yılmaz, A., Morgil, İ., Aktuğ, P. ve Göbekli, İ. (2002). Ortaöğretim ve Üniversite Öğrencilerinin Çevre, Çevre Kavramları ve Sorunları Konusundaki Bilgi ve Öneriler. *H. Ü. Eğitim Fakültesi Dergisi*, 22, 156-162.

Author Information

Ozkan Akman

Gaziantep University, Nizip Faculty of Education
Contact E-mail: akmanozkan@email.com

Mustafa Murat Cay

Gaziantep University, Nizip Faculty of Education

The Contribute of the Word Roots in Reading among Normal and Dyslexic Readers

Haneen WATTAD
Alqasemi College

Abstract: The aim of the present work is to stress the contribute of the word roots in reading among normal and dyslexic readers. The lexical status of the root morphemes were examines using two priming paradigms: the masked priming; and the cross-modal immediate repetition task among regular and dyslexic readers: Grades sixth, eighth and tenth. The hypothesis was that the roots of words are lexical entities which have a role in organizing the lexicon, and facilitate the access to a wide countenance of verbs among regular and dyslexic readers from ages of elementary to high school. It was also assumed that the effect of visual morphological priming and effect of auditory morphological priming will be stronger among those who have a reading disability and among young readers, compared to more skilled readers. Further, it was assumed that the manner of representation of morphologically complex words and how to access them is similar among the all readers in reading Arabic. In addition, it was assumed that the pace of building a mental lexicon among dyslexic readers is slow, but the lexicon itself is similar to that of regular readers. The findings confirmed the first hypothesis about the roots. It was also found that regarding readers with dyslexia, the manner of representation of the words that are morphologically complex is different compared to regular readers. It was concluded that this difference is a result of a deficit in the initial processing process among these readers, and that they are apparently relying on other channels except the morphological one when identifying verbs, which emphasizes the uniqueness of the Arabic language, its morphological density and its phonological and lexical richness.

Keywords: Root morphemes, Priming paradigm, Lexical status, Dyslexic readers, Morphological awareness

Introduction

Recent studies have indicated that morphological awareness makes an important contribution to the quality of reading (Ben- Dror, Bentin & Frost, 1995; Casalis & Louis-Alexandra, 2000; Leikin & Even Zur, 2006). A reader's ability to reflect upon the meaning of morphemes and their ability to parse and manipulate them is termed 'morphological awareness'. It contributes to reading ability over and above the contribution of phonological awareness. (Schiff & Raveh, 2007).

In Ben- Dror and Frosts' (1995) research, it appeared that children with developmental dyslexia displayed morphological weakness in spoken language and its comprehension. Subjects failed morphological assignments, which negatively affected their reading. A similar study by Elbro and Arnbak (1996) provided similar results among dyslexics compared to regular readers in tasks identifying words, and the authors emphasised that morphological awareness is significantly linked to a reader's ability to identify words. These results have been reinforced in many studies examining the morphological effect of the letter identification and production process on successful reading acquisition. (e.g. Abu Rabia & Saliba, 2008; Abu Rabia & Abu-Rahmoun, 2012; Levin, Ravid & Rapaport, 1999; McBride-Chang, Shu, Zhou, Wat & Wagner, 2003; Senechal, 2000; Taha & Saiegh- Haddad, 2016).

Studies in the field have demonstrated that regular pupils (without dyslexia) develop sound morphological abilities and awareness of word structures according to their age range, and even understand and develop the morphological links between words, in contrast to those with dyslexia (young and adult) who find it difficult to understand morphological relationships and carry out morphological manipulations in morphological tasks

- This is an Open Access article distributed under the terms of the Creative Commons Attribution-Noncommercial 4.0 Unported License, permitting all non-commercial use, distribution, and reproduction in any medium, provided the original work is properly cited.

- Selection and peer-review under responsibility of the Organizing Committee of the Conference

(Abu-Rabia, 2007; Abu-Rabia & Awwad, 2004; Bryant, Nunes & Bindman, 2000; Carlisle & Feldman, 1995; Kaminsky, Eviatar & Norman, 2002; McBride-Chang et al., 2003; Shankweiler et al., 1995).

Sound morphological awareness positively affects and helps the reading process, since it helps readers to have the ability to process words morphologically and store them using their morphological structure in their mental lexicon, which affects the process of identifying new words efficiently through morphological analogies with similar words stored in their lexicon (Abu Rabia & Wattad, submitted; Abu Rabia & Taha, 2004; Abu Rabia & Awwad, 2004; Beringer et al., 2010; Deacon & Kirby, 2004; Elbro & Arnbak, 1996; Ravid & Schiff, 2006; Roman et al, 2009; Sénéchal et al., 2006).

The Root (الجذر)

The root is the formative and semantic nucleus of a word in Arabic and Hebrew. For example the groups of words *كاتب* (ka:taba, corresponded with), *مكتوب* (muka:tabt(un), correspondence) are a 'morphological family' (Berman, 1987) because the words in this family share the same root, *ك ت ب* (k-t-b), and their meaning is linked to writing. In standard Arabic, there are more than 6000 different roots (Boudelaa & Marslen-Wilson, 2011).

There are two types of roots in Arabic (Holes, 1995; Wright, 1995). The first type is strong roots, such as *قرب* (q-r-b; closeness), *كتم* (k-t-m; hidden) and *ختم* (x-t-m; end), which are so called because of their ethnographic and phonological transparency, since their three consonants are expressed methodically in any derivation or declension in any surface structure. The second type of roots in Arabic are weak roots in which one phoneme glides: *و*/w or *ي*/y as one of their consonant components. For example, *نوم* (n-w-m; sleep), *وحد* (w-h-d, unity) (Awwad, 2013).

Roots have three elements: semantic, phonologic and orthographic. In the semantic sense, the root is the main content topic of a word and connects words belonging to the same word family. Words can share the same root letters and at the same time have two or more different meanings.

In the phonologic sense, the same three or four root consonants appear in words from the same root, and are linked phonologically. The phonologic unity of a root is breached in cases where roots are likely to have, or cases in which there is, assimilation of root consonants to one of the pattern consonants that appear afterwards. In the orthographic sense, writing root letters does not change despite phonological changes that occur in root consonants, and so there is a perception that roots are linked to their various aspects: to the type of root – whether it is strong or weak; to phonological changes in root consonants; and to transparency levels in the semantic connection between words. Orthography, in fact, plays a crucial role in representing a root because of the consistency and uniformity of letters (Ravid & Bar-on, 2005).

The Morphological Role in Decoding Words among Dyslexic Readers(DR) and Normal Readers (NR)

Current studies show that DR have both a phonological flaw and greater language processing difficulties, particularly at the morphological processing level. Studies refer to normal developmental ability to indicate, or react to, morpheme meanings and decompose and manipulate these morphemes as morphological awareness. This contributes more to reading and pronunciation ability than phonological awareness (Carlisle, 1995; Carlisle & Nonanbhoy, 1993; Hauerwas & Walker, 2003; Mahony, Singson, & Mann, 2000).

Several studies suggest that DR are distinctly delayed in grammatical skills relative to NR (Carlisle, 1987; Siegel & Rayan, 1984; Tyler & Nagy, 1990). Some researchers have studied morphological awareness development and its connection to reading acquisition. There is a positive correlation between morphological awareness and reading achievement levels in several languages (Author,2001,2007; Author & others ,2003, 2004, 2012; Ben-Dror, Bentin, & Frost, 1995; Joanisse et al., 2000).

Investigating the effect of morphological structure on automatic word recognition has been made possible via the priming paradigm and the cross-modal priming. In pairs of words that include the prime and the target, participants are instructed to decide whether the target is a word of the language. The relationship between the prime and target depends on the goals of the study. In the case of using cross-modal priming, the prime and target are distinct perceptual events, with a visual target presented immediately at the offset of an auditory prime (Boudelaa, 2014). Using the priming paradigm in studies on the morphological structures in Hebrew and Arabic

revealed that exposure to the morphemes (root and patterns) facilitates the identification of words derived from that root (Boudelaa, 2014; Deutsch et al., 1998; Frost et al., 1997).

Rueckl and Galantucci (2005) examined the locus of morphological priming effects based on studies of repetition priming. It assumes that morphological effects arise from the central mental lexicon that is organised morphologically and contains morphemic entries and/or connections between morphologically related words. Rueckl and Galantucci stressed that morphological priming, like repetition priming, may include several components. They found strong effects of the same-modality morphological priming, and they hold that the morphological priming includes a modality-specific component in addition to the modality-independent one. Their findings also show that response times to targets in the two processing components operate in a cascaded manner, with the modality-specific morphological processes exerting their influence earlier than the modality-independent processes.

A similar study conducted in Hebrew by Raveh and Shiff (2008) investigated the quality of implicit morphological knowledge in adult Hebrew readers with developmental dyslexia. An attempt was made in this study to distinguish between these alternative interpretations by contrasting morphological priming effects in the visual and auditory modalities. Only the students with phonological dyslexia, who exhibited relatively good performance in the orthographic judgment task, exhibited repetition priming but not morphological priming. Strong repetition and morphological priming effects were found for participants with dyslexia when the stimuli were auditory.

Current studies also show that root mediation among young Arab DR leads to improved reading (Ravid, 2001; Ravid & Farah, 1999; Ravid & Schiff, 2006; Schiff & Ravid, 2004; Taha & Saiegh-Hadad, 2016). Similar findings emerged in studies of Hebrew (Ravid & Schiff, 2006; Schiff & Ravid, 2004).

The Current Study

Despite indications of morphological knowledge absences among dyslexics, studies have shown that they employ morphological analyses as a helping strategy in the reading process to overcome the difficulty decoding orthographic code. Nonetheless, there have not been enough studies examining how the mental lexicon is arranged among Arabic-speaking dyslexics of various ages or their strategies for deciphering words. No studies exist regarding whether these readers build their mental lexicon similarly to NR but at a slower pace, meaning, building with development and improved performance and dependent on their reading level, or whether their lexicon is constructed differently.

Do the verb roots of words constitute entities with a role in arranging the mental lexicon among NR and DR at different ages, and do these entities serve different readers when decoding words to the same extent and build their lexicon in the same way?

In the current study, we attempt to answer these questions and to clarify the real locus of the root verb units, and their role in arranging and building the mental lexicon reading of normal and dyslexic pupils of various ages. We hypothesised that the way complex words are represented morphologically and are accessed is similar among Arabic DR and NR. And dyslexics build a mental lexicon more slowly, but the lexicon itself is similar to that of NR and is built as a child develops. Our study was performed after reviewing the studies conducted in this field. It was designed by considering the recommendations for future studies of these prior studies.

Method

Participants

The research sample consisted of three age groups, each with 90 Arab pupils from different Haifa region schools, all native Arabic speakers. The first group included 30 NR in 6th grade, 30 DR in 6th grade, and 30 students with a comparative reading age of normal 4th-grade readers.

The second level included 30 NR in 8th grade, 30 DR in 8th grade, and 30 students with a comparative reading age of normal 7th graders. The third level included 30 NR in 10th grade; 29 DR 10th graders; and 32 students with a comparative reading age of normal 9th graders.

Research Tools

We used a computer to manage lists of words for experiments. Time was measured using DMDX – Damster Display System software, developed by Forster at the University of Arizona (Forster & Davis, 1984).

The experiments were carried out using masked priming and cross-modal immediate repetition task techniques developed by Forster and Davis (1984). Priming occurs when processing words is facilitated as a result of a preliminary stimulus. The rationale is that if lexical representation of words reflects their morphological structure, and decoding them first requires decoding those structures, then mental representations of words with identical morphemes and arousing representation of the priming automatically stimulate TW representation (Forster, 1999).

The masked priming technique is also advantageous in being very sensitive to excessive overlapping between word forms, and it is therefore better suited to investigating effects of morphological connections at the form level than the semantic or conceptual levels.

The Experiments

Priming with roots – visual lexical decisions

The experiment goal was to examine the lexical status of root morphemes and their role in lexical access. We sought to examine whether early exposure to roots could facilitate or speed up the lexical decision regarding TWs derived from that root.

The related condition

This condition constituted the research goal that the PW was a root, with the TW derived from this root. For example: root was *صَدَقَ* [s-d-k] and verb *تَصَادَقَ* (became friends).

Priming using roots – auditory lexical decisions

This experiment was identical to the first experiment, except the stimuli were auditory. Participants had to decide whether the word they heard exists in the language.

Results

Statistical Analysis

We used a mixed linear model to examine the research hypotheses. This model tests two experimental measures (success percentage [SP] and reading time [RT]), including group (1= NR, 2= DR, 3= comparative reading age [CR]) and experimental conditions, E1= priming with roots – visual lexical decisions; E2= priming using roots – auditory lexical decisions) as fixed effects and class as a random effect. We wanted to draw conclusions on participants of different ages. Furthermore, we assumed that 6th graders have a different starting point from 8th or 10th graders in the effect of the dependent variable, assuming all other explanatory variables are the same. The interactions between the different effects in the model were also calculated.

The mean response time was calculated on the basis of correct reaction data. When participants made mistakes in their lexical decision or did not answer at all, the RT calculations were removed from the results analysis, as were words whose RT was over 5000 milliseconds. A similar calculation was made for the SP of each subject in each condition.

Experiments 1 and 2

In E1 and E2, the lexical status of verb root morphemes in lexical access was tested. The goal of E1 was to examine whether a PW facilitates lexical decisions regarding a TW when both share the same root. The goal of

E2 was to neutralise dyslexics' failures deriving from visual presentation in order to understand whether failures depend on morphological flaws during the lexical processing stage (a stage that is a process of model morphological representation) or whether they are derived from flaws in the initial processing stage.

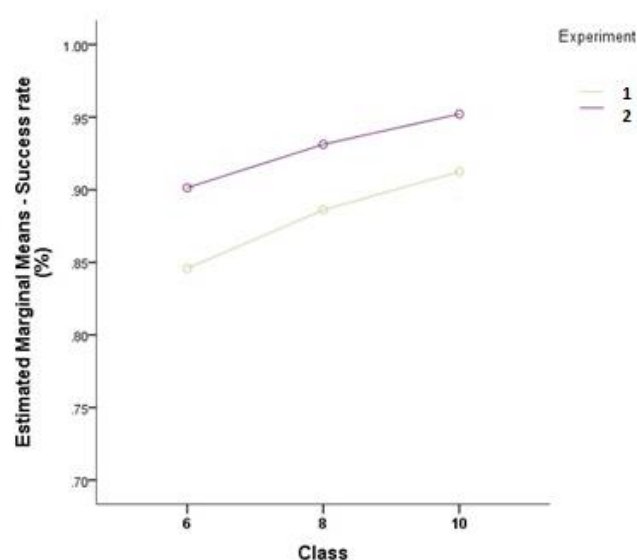

Figure 1

Figure 1 shows that the interaction between the experimental condition and the different age groups. This finding highlights that roots constitute lexical entities and play a significant role in organising the mental lexicon among NR and DR at different ages.

The auditory-morpho priming effect in the root test was stronger than the visual effect among all participants, and it contributed to accelerating lexical decision and answer accuracy (SP). The auditory-morpho priming effect contributed more to accelerate lexical decisions among all groups; however, it did not increase the accuracy of the answers, As such, our hypotheses (the auditory morphological priming effect will be stronger among dyslexics than a visual effect, and the auditory or visual morphological priming effect will be stronger among dyslexics and younger readers than more skilled readers) were confirmed.

In the root words test, DG performances were improved from one level to the next in SP conditions but not RT conditions, indicating that roots contributed to participants' accuracy, but did not enhance their lexical decisions. Lexical decisions among dyslexics were faster in all groups; therefore, it is only logical that they showed no significant differences regarding response time when moving from one age level to another. The two control groups demonstrated improved linear performance in conditions when moving from one level to another. It appears that the root, in contrast to the pattern, enhanced lexical decisions and improved performance among all participants.

Discussion

The current findings showed how morpheme units are stored, arranged, and used, in verb systems — word roots— enabling us to reach conclusions regarding the development of the mental lexicon in Arabic. This process is apparently linked to reading levels and experience. The current research findings indicate that word roots are lexical entities with a role in organising the mental lexicon of all research groups at all age levels. Apparently, employing RMs begins in 4th grade and strengthens with age.

These findings are explained in Boudelaa's (2014) model and are part of the model of word representation in Hebrew speakers' mental lexicon, developed by Frost et al. (2000), in which the mental lexicon is comprised of two levels of representation. Whole lexical units (words) are represented at one level, and sublexical units (root morphemes) at a deeper level. Both levels are interconnected, and one can trace a word through direct access on an ethnographic or phonological basis, or by morphological decomposition during which a root is found. These

processes are likely to be simultaneous, and the word is deciphered using the faster of the two, which is dependent on the word's frequency level in the language (Deutsch et al., 1998; Frost et al., 1997, 2000).

With this model, all words derived from the same root are arranged in the mental lexicon around the RM, which constitutes their common representation (Deutsch et al., 1998). Our findings indicate that among the different groups, especially the two control groups, it seems Arabic verbs derived from the same root are connected by this morphological unit. Therefore, it appears that the Arabic verb system's lexical structure is similar to that of Hebrew, and that the Arabic verb lexicon also consists of two representation levels: whole lexical units, which are high-frequency words, meaning less frequent morphological decomposition (Boudelaa, 2014) and no need for decomposition due to their familiarity, because readers' written units are more developed and every word becomes one written unit; and, at a deeper level, sublexical units (root morphemes), enabling morphological decomposition of low-frequency words.

Conclusion

The conclusion regarding the importance of morphological processing and awareness also (specially- about root morphemes) supports the hypotheses of Tseemeli and Seymour (2006), who assumed that sound morphological awareness and meta-morphological ability allow one to reach conclusions regarding morphological relations among words, enabling accurate spelling, especially for words derived from others. Tseemeli and Seymour found that among dyslexics, for whom spelling processes are difficult, a lack of morphological awareness constitutes a central cause for observed absence of spelling skills.

This finding is congruent with and supports the assumption of Rueckl and Galantucci (2005) and the findings of Shiff and Raveh (2008). As previously discussed, these deficits are explained by the problem dyslexics have in the early process of identifying written words and a lack of ability to automatically extract visual and orthographic features from the printed word, causing the limitation in their learning ability.

Recommendations

In the current research, we did not examine the morphological qualification of dyslexics whose impairments are categorised into different sub-groups of dyslexia, as did Joanisse et al. (2000). We chose the dyslexics in our study according to measurements of reading texts and isolated words, but did not sort them into types of reading impairments and characteristics. The selected group was possibly heterogenic in terms of reading impairment and its traits; therefore, the organisation of the mental lexicon and how morphological structures are represented may be different in every sub-group. Thus, it is important in future research to consider characteristics and various types of impairments, as well as to sort a group of dyslexics into sub-groups to achieve more accurate results.

Another idea is classifying presented words according to frequency (high/low), because some researchers (Bybee, 1995; Katz et al., 1991) have argued that a word's frequency factor dictates lexical storage rather than its morphological complexity. Therefore, morphological decomposition is necessary only when encountering a new word, derived or conjugated, or a low-frequency word. Readers must then employ morphological knowledge to understand the meaning. More frequent words have a greater chance of storage in their whole form, and this is also supported by Boudelaa's OMD model (2014). It is therefore desirable that future studies classify word lists by frequency and control this demarcation during experiments.

Acknowledgements

This section is based on wattad and Abu Rabia (submitted) - The Lexical Status of Basic Morphemes Constituting Verbs in Arabic among Normal and Dyslexic Native Readers: A Developmental Model.

References

Abu-Rabia, S. (2007). The role of morphology and short vowelization in reading Arabic among normal and dyslexic readers in grades 3, 6, 9, and 12. *Journal of Psycholinguistic Research*, 36(2), 89-106.

- Abu-Rabia, S., & Abu-Rahmoun, N. (2012). The role of phonology and morphology in the development of basic reading skills of dyslexic and normal native Arabic readers. *Creative Education*, 3(7), 1259.
- Abu-Rabia, S., & Awwad, J.S. (2004). Morphological structures in visual word recognition: The case of Arabic. *Journal of Research in Reading*, 27, 321-326.
- Abu-Rabia, S., & Saliba, F. (2008). The lexical status of basic Arabic verb morphemes among dyslexic children. *Australian Journal of Learning Difficulties*, 13(2), 115-144.
- Abu-Rabia, S., Share, D., & Mansour, M.S. (2003). Word recognition and basic cognitive processes among reading-disabled and normal readers in Arabic. *Reading and Writing*, 16(5), 423-442.
- Abu-Rabia, S., & Taha, H. (2004). Reading and spelling error analysis of native. *Reading and Writing*, 17(7-8), 651-690.
- Ben-Dror, I., Bentin, S., & Frost, R. (1995). Semantic, phonological, and morphological skills in reading disabled and normal children: Evidence from perception and production of spoken Hebrew. *Reading Research Quarterly*, 30(4), 876-893.
- Berninger, V.W., Abbott, R.D., Nagy, W., & Carlisle, J. (2010). Growth in phonological, orthographic, and morphological awareness in grades 1 to 6. *Journal of Psycholinguistic Research*, 39(2), 141-163.
- Boudelaa, S. (2014). Is the Arabic mental lexicon morpheme-based or stem-based? Implications for spoken and written word recognition. In E. Saiegh-Haddad & R.M. Joshi (Eds.), *Handbook of Arabic literacy: Insights and perspectives* (pp. 31-54). Netherlands: Springer.
- Bybee, J. (1995). Diachronic and typological properties of morphology and their implication for representation. In L.B. Feldman (Ed.), *Morphological aspects of language processing* (pp. 225-246). Hillsdale, NJ: Lawrence Erlbaum Associates
- Carlisle, J.F. (1987). The use of morphological knowledge in spelling derived forms by learning-disabled and normal students. *Annals of Dyslexia*, 37(1), 90-108.
- Carlisle, J.F. (1995). Morphological awareness and early reading achievement. In L. B. Feldman (Ed), *Morphological aspects of language processing* (pp. 189-209). Hillsdale, NJ: Lawrence Erlbaum Associates.
- Carlisle, J.F. (2000). Awareness of structure and meaning of morphologically complex words: Impact on reading. *Reading and Writing*, 12, 169-190.
- Deacon, S.H., & Kirby, J.R. (2004). Morphological awareness: Just “more phonological”? The roles of morphological and phonological awareness in reading development. *Applied Psycholinguistics*, 25(2), 223-238.
- Elbro, C., & Arnbak, E. (1996). The role of morpheme recognition and morphological awareness in dyslexia. *Annals of Dyslexia*, 46(1), 209-240.
- Forster, K.I. (1999). The microgenesis of priming effects in lexical access. *Brain and Language*, 68(1), 5-15.
- Forster, K.I., & Davis, C. (1984). Repetition priming and frequency attenuation in lexical access. *Journal of Experimental Psychology: Learning, Memory, and Cognition*, 10(4), 680.
- Frost, R., Deutsch, A. & Forster, K.I. (2000). Decomposing morphologically complex words in a nonlinear morphology. *Journal of Experimental Psychology: Learning, Memory and Cognition*, 26(3), 751-765.
- Joanisse, M.F., Manis, F.R., Keating, P., & Seidenberg, M.S. (2000). Language deficits in dyslexic children: Speech perception, phonology, and morphology. *Journal of Experimental Child Psychology*, 77(1), 30-60.
- Katz, L., Rexer, K., & Lukatela, G. (1991). The processing of inflected words. *Psychological Research*, 53(1), 25-32.
- Raveh, M., & Schiff, R. (2008). Visual and auditory morphological priming in adults with developmental dyslexia. *Scientific Studies of Reading*, 12(3), 221-252.
- Ravid, D., & Schiff, R. (2006). Roots and patterns in Hebrew language development: Evidence from written morphological analogies. *Reading and Writing*, 19(8), 789-818.
- Rueckl, J.G. & Galantucci, B. (2005). The locus and time course of long-term morphological priming. *Language and Cognitive Processes*, 20(1/2), 115-138.
- Schiff, R., & Ravid, D. (2004). Representing written vowels in university students with dyslexia compared with normal Hebrew readers. *Annals of Dyslexia*, 54(1), 39-64.
- Siegel, L.S., & Ryan, E.B. (1984). Reading disability as a language disorder. *Remedial and Special Education*, 5(3), 28-33.
- Taha, H., & Saiegh-Haddad, E. (2016). The role of phonological versus morphological skills in the development of Arabic spelling: An intervention study. *Journal of Psycholinguistic Research*, 45(3), 507-535.
- Tsesmeli, S.N., & Seymour, P.H. (2006). Derivational morphology and spelling in dyslexia. *Reading and Writing*, 19(6), 587-625.
- Tyler, A., & Nagy, W. (1990). Use of derivational morphology during reading. *Cognition*, 36(1), 17-34.
- Wright, W. (1995). *A grammar of the Arabic language*. Cambridge, UK: Cambridge University Press.

Author Information

Haneen Wattad

Alqasemi college, Israel

Baka algarbia

Contact E-mail: swattadhaneen@yahoo.com

An Artificial Intelligent of Princess Mandalika Legend: A New Strategy to Sustain the Resort of Mandalika-Lombok

Yuke ARDHIATI

Pancasila University of Jakarta

Abstract: A qualitative research is focused on a new architecture concept of the Mandalika Tourist Region of Lombok. As an Infrastructure Project to rapidly a one of the Ten National tourism of Indonesia's priority. According a phenomenological research within a multidiscipline actors was found an uniqueness of the Sasak local legend, named a story of the Princess Mandalika. She is a myth of the Lombok Land. Until now, the annually festival to remind her legend was held on February. To remind her the videos, performing art, dance, and sculpture was created. Especially to enrich the resort region an artificial intelligent of architecture may create as a part to sustain the spirit of the legend. An Augmented Reality (AR) may created in the surround of the district area. The Augmented Reality (AR) is a visual communication graphic design related the Princess Story through the added images on the real world. Visitors my need a 'smart glasses' within the three general characteristics; a). The combination of real environment with virtual objects, b). An Interactive display, c). a Display in 3D. By a Visual Prototyping Augmented Reality as images can manipulation the Princess Mandalika present on the region within the Sasak Architecture background. So, by exploiting the legend the foreign tourists more enjoyed about the locale culture of Indonesia. In architecture is a part of the architecture-event.

Keywords: Architecture-event, Artificial intelligent, Augmented reality, The princess mandalika, Sasak architecture

Introduction

The Mandalika Resort at Lombok

Recently, the tourism region of Lombok had gained attention in the President Joko Widodo era (2014-2019). To encourage the national tourism destinations, so he has set 10 priorities of tourism destination projects. In the previous era of President Susilo Bambang Yudhoyono, he also concerned in this region by published his policy in 2011. Both of Presidents has to give attentions to the same region as well as to continue the President Suharto's program. As a tourist region, has a geographical region that has been designated by a governmental organization or tourism bureau. Usually, the tourism region has name created by specifically for tourism purposes. The names often evoke certain positive qualities of the area and suggest a coherent tourism experience to visitors. Now the tourism region named the Mandalika tourism district had located in Central Lombok, Nusa Tenggara Barat islands had managed by ITDC -Indonesia Tourism Development Corporation. The Mandalika tourist region is one of "The 10 of the Leading of Tourism Destination" composed as the Indonesia's main tourism area, and it set by President Joko Widodo, among others; (1) Lake Toba, (2) Tanjung Lesung (3) Borobudur, (4) Bromo, (5) Tengger, (6) Semeru, (7) Mandalika, (8) Wakatobi, (9) Morotai Island and (10) Labuan Bajo (sportnews, 2016). In achieving the target of the foreign tourists visit as well as 12 million peoples, and 260 million trips of the locale tourist the the Minister of Tourism, Mr. Arief Yahya (Kompas, 2015) was tasked by the President to set up a strategies number to prepared, divided into two types, namely the National Tourism Strategic Areas and the Special Economic Zone Tourism – KEK. The ten of the tourism destinations that need to be explored the attractiveness. The major of the tourist destination that has a natural panoramic of beach, such as Tanjung Lesung, Mandalika, Wakatobi, Morotai and Labuan Bajo. To establishment the Mandalika Resort needs to explored the advantages the sense of place. Joko Widodo who always wish to create a new ways to make a sense of the events "festival for the peoples". It will be associated with the tourism destinations of the Mandalika tourist region by exploration the locally that can be carried as a festival that is

- This is an Open Access article distributed under the terms of the Creative Commons Attribution-Noncommercial 4.0 Unported License, permitting all non-commercial use, distribution, and reproduction in any medium, provided the original work is properly cited.

- Selection and peer-review under responsibility of the Organizing Committee of the Conference

worth the socio-economic and cultural. He inspired by Soekarno thought about the cultural age than the ruling class.

As the tourist region, the Mandalika contained a commercial establishment that to provide most of a vacationer's wants. There are maybe facilitating such as food, drink, lodging, entertainment, sport and also shopping including the resort hotel. PT ITDC as the resort management mandate of the Indonesia government have prepared a visionary Master Plan which includes the building regional infrastructure and facilities of international standard. (Masterplan, 2015, ITDC). They had preparation the investment strategies for the investors to invest in the Mandalika Tourism Region around 1,255 hectares. The Masterplan in 2015 are contains three (3) of major development of Mandalika Tourism is "The Place To Be". First, to creates the independent and sustainable tourism. Second, to provide the international standard infrastructure and, the third, to develop the principle of preservation and ecological restoration. To accelerate the investment it need to prepare the smooth circulation integrated with investments and rate the economy of local communities. Basically, the tourist region facilities including the hotel resort. The originally term of resort may be used for a hotel property that provides an array of amenities including entertainment and recreational activities. Herewith, the purpose of this study is expected to contribute in the forms of:

1. Inspiring discourse on creative people in the field of Information Technology in general and Visual Communication Architects and Designers, explores designs with existing (and future) technological support.
2. preparing a new paradigm related to AI Technology, Increased Reality
3. Utilizing future technology for local content of tourism in Indonesia. Through the Visual Design Prototype for Enhanced Reality Technology with Google Glass devices (for the Mandalika Resort area in Lombok) which aims to enrich one of the 10 leading tourism destinations in Indonesia.

The Artificial Intelligent in Architecture

Now, Increased Reality Technology has the opportunity to enrich ambience in tourist destinations through ways that have not been thought of before, for example; a). Able to present images of 'figures in the past dimension' and even visualize mythical stories into the present reality, b). Presenting visually with the atmosphere you want to feel, (atmosphere of the sea, mountains, morning, evening, or night) c). Even presenting other information such as: infographic, information / explanation of certain artifacts, including narratives, storylines as well as sponsorship messages as philanthropy. The idea of the union can be realized through devices equipped with Enhanced Reality technology, one of which is "Google" smart glasses, or called: "Google Glass".

Referring to Widya and Ardhiati, 2013 and Milgram and Kishino's post, 1994, said the possibility of merging and fusing the real world and cyberspace into a continuum of virtuality. On the far left side is a real environment that only contains real objects, and the far right is a virtual environment that contains virtual objects. In the way the Increased Reality works, which is closer to the left side, the environment is real and objects are virtual, while in augmented virtuality or virtuality increases, which are closer to the right side, the environment is virtual and objects are real. Increased reality and added virtuality are combined into mixed reality or mixed reality.

In addition to offering a variety of advantages and benefits offered this technology also gave rise to criticism, in the form of concerns (especially) the negative social and health impacts that will be caused, especially after Google announced the patent rights and Smart Glasses will be launched at the end of 2013. However, we must remain prepared for technological advances and can use them for positive purposes, because their ability to create new spaces and dimensions in various disciplines of imaginary architecture is the advantage of the technology of Increased Reality.

Mandalika of Lombok Folklore Legend as the Resort Storyline

According to President Joko Widodo's wish to create "festival for the peoples" so it adopted into Mandalika Resort then, at 2017 PT ITDC hiring to PT Perentjana Djaja Architect to strengthen the conceptual by a collaborative design team between architect, masterplaner, landscaper, business analyst, civil engineer, anthropologist, and mitigation expert. By referring a phenomenological investigation in the Central of Lombok region so Architect adopted the Event-Cities Theory (Tschumi,1997) and created Architecture-Event of Derrida's (Derrida, 2009) such as; (a) sequences, (b) the open-serialize, (c.) narrative, (d) cinematic, (e) the drama, and (f) the choreography. According to Storm's idea of tourist region trend; "Every region had its own 'soul'...an organic part of the nation" (Storm, 2003), then elaborated the folklore legend Princess Mandalika of

has related with the locale heritage tradition of “Bau Nyale” Festival to be the resort storyline and the closely way to “branded” of resort region.

Architecture-Event Concept of the Princes Mandalika

By refers to Architecture-Event concept of Derrida thus it necessary to adopt a storyline as the core of resort’s theme. The storyline will be mutually within the six criterias of the Architecture-Event concept, namely; a. sequences, b. the open-serialize, c. narrative, d. cinematic, e. the drama, and f. the choreography (Derrida, 2009). The six criterias will adopt as the spirit of the Resort Design of Guidelines – RDGL. The Mandalika tragic legend is the storytelling about the “Princess of Mandalika”. A fairy tale of the beauty princess on the South coast of Lombok. She is a beautiful daughter of the King of Tonjang Beru. The beauty and elegance of the Princess was invited the competitive situation that affects hardness of the Princes of the Earth Sasak-Lombok. The competition atmosphere that gave a depth concern of the Princess. She need to avoid the fragmentation by doing a samadi or pray to Godness how to decide to throw in one of the princes. She got an inspired during her silence samadi. She invites all of the Princes to came at the early morning in South of the Kuta beach in Lombok in the 10-20 of the months of Sasak. All the Princes and Lombok people came in the South Beach. In the early in the morning the Princess Mandalika arrived by carried on the stretcher gold, and stopped at a pile of rocks near the sea. The Princess stand up while outspoken that, on this day, she can’t choose one among all the Princes. The princess believed her destiny will be becoming as the “nyale” or worms that are beneficial for all the Sasak people. Suddenly, she threw herself into the South sea, and the legend continues by a “nyale” tradition as a ritual tradition of Lombok to see a set of colourfull worm that only comes once a year on the same beach.

The Monad’s of Mandalika-Lombok

To explore the indigenus of Sasak is need to finding the core of the Sasak culture named the monad of the Mandalika itself as the basic design. The monad term of Leibniz in 1898 to describe the immortal of the artistic soul. Is the intangible of atom or the smallest molecules particle of the objects. Leibniz was found the monad of Baroque around the 1660-1760 based on the form of the material fluidity, elasticity, the shape of mechanical as well as the spirit of immaterial forms named drapes/ indentation fabric. The Indonesian monad was interpreted through the basics of art carving namely “ukel” - a never ending circular shape of the Mandalika Endemic Flower. By spatial investigation into a heritage housing of Karang Bayan of Lombok Barat district was found the originally of “Mandalika-Carved” located as the twin doors of the heritage. Then, the “Mandalika –Carved” adopted as the architectural based of design.

A Backbone of Mandalika’s Main Road and TOD System

By a phenomenological investigation in spatially experience around the region’s extensive reach 1,255 ha are the hilly lands and beaches. Because of the huges of the region then it need to easely the estate management. Finally, the Architect Team propose the solutions based on the region topography and the natural panoramic has two main potential namely West Region and the East Region. The result of the study is to find a “Resort Design Guideline (RDGL)” as a world-class tourism region facility. To visualized it refers to the Mandalika Masterplan 2015 by analyst the potentially of the resort region and proposed such as; (1) A Backbone of Mandalika Resort main road (2) The toponimi name of the Mandalika Districts Area (3) “the Teten of Sasak” Cultural Buffer Zones (4) The Natural Disaster at once as the Landmark of Mountain Hills.

A Backbone of Mandalika’s Main Road and TOD System

The TOD - Concepts Transit Oriented Development is the best point to solve the huge tourist region of Mandalika Resort to easily visitors integrated system of transport. The potential travelers in around on the Kuta Beach of Lombok may facilitated as well as by the inspiring atmospheres. By located the TOD at the Marina District around the Kuta Beach. The Marina beach is planned to be the berthing ships from Australia and others, so it potentially as the mixed used area of the waterfront area. The variety activities are supported by a public open space such as the open plaza that functioned as a Folk Art Performances at once to anticipation of natural disaster. The monorail of Mandalika may be prepared by the Indonesian monorail of PT Pembangunan Perumahan. They need the double track of monorail services tourist travel to back and forth from/ to Marina. The

Architect Team had proposed a panoramic backbone road of Mandalika by explore all of the region potentially vista such as; mountains, endemic plants (typical flowers), lagoon, rivers, and natural beach. The many of the Mandalika hills looks like similar characteristic so visitors may had loost of orientation. Then, it need to the hills identity at once with the space to anticipated the natural distater of Lombok such as tsunami and flood.

“The Teten of Sasak” as a Cultural Buffer Zones

The uniqueness of architecture proposed is to accommodation the originally of Sasak people of Lombok as a part of the tourist region by named “the Teten of Sasak” as a buffer zones to give an appreciation to the locale people of Lombok island (Faturrahman, 2017). According Faturrahman as the Sasak’s of Lombok expert, the Teten is role as a melting pot of the culture to reduce the economic risk of disparities between the tourist and the original people of Sasak. The Teten may be embodiment as a joint area between the Sasak with tourists for economic trade/ exchange goods of Sasak’ s craft by facilitating a vernacular architecture of Sasak named Berugah. (Fathurahman, 2016).

The Toponimi Named of Mandalika Districts Area

By using the Toponimi named theory of places, then Architect proposed the Mandalika District creates by the spirit of place of Mandalika. Architect proposed to rename the old districts by replacing the essentiality based on the spirit of the origin site/place. The indigenous of the cosmology of Lombok maybe adopted as the spirif of Lombok. All the Mandalika Districts tobe in 18 districts divided as the 16 Districts of the Old Districts and the Additional District of MotoGP District and the Underwater District, (A) Cultural Village Renewal, (B) The Gateway, (C)The Lagoon, (D)The Cultural Village, (E) The Family District, (F) The Hill Top West, (G)The Golf District, (H) The Heart West, (I) The Hill Top East, (J) The Heart East, (K) Luxurious Enclave, (L) The Conservative, (M) Theme Park, (N) Fisherman Wharf District, (O) The Mangrove, (P) (Q)The Moto GP, (R) The Underwater Facility.

The Mitigation Area of Tourism Region

By reffers to the rules of BNPB – Badan Nasional Penanggulangan Bencana as the government care to the natural disaster (BNPB, 2010). In other hand the huge of resort region needs to the architectural sign, such as the statue, the sculpture, the monument, the tower etc. Then, the Architect had proposed the Mandalika natural disaster catchment areas at once as the Mandalika landmark of the mountain hills. By create a serial of landmark of architecture so, PT ITDC as the resort management had investment of to the region to the tsunami natural distaster inlines with the tourist destination. The specific treatment requirement of the space within a stage construction as the tsunami barrier. By create an “arsitektur -panggung” – is the levelling architectural to protect the tsunami disaster. The morphology of “arsitektur-panggung” created as the mitigation area at once as the landmark architectural of the resort region. (Michalski, 1998).

To Generate the Creative Economic of Festival

The “Bau Nyale” Festival is an annual tradition in the early morning on the Kuta South Beach of Lombok. The estimated tourist visitors more than 100,000 peoples. The “Bau Nyale” Festival activities, among others; (a) the cultural parade, (b) the culinary festival, (c) the Princess Mandalika Competition, (d) the Betandak-Bekayak Event, (e) The commemoration of “Bau Nyale”; the Peresean, the Cilokaq Festival, the Surfing Contest, the Volley Beach and the Photography Contest. The commemoration of “Bau Nyale” celebrate then the locale governments by closed to all schools and their institutions in order the peoples can flocked to the event. The big event encourages the atmosphere of joy because they lived together in the open space area of surround of the Seger Hills.

Based on the “Bau Nyale” Festival 2017 the district created a temporary parking, a livinghood along the coast, a temporary market, a temporary toilet, a stage entertainment. The early morning is the peak of the “Bau Nyale” Festival. Visitors took place the seashore to across the sand and rocks in the South Beach. So, they prefer to ware a shorts skirts, pants or clothing to avoid the hit water from the beach. By learned the habit of visitors during the festival, so the Mandalika Resort can encourage to visitors to ware the originally Sarong of Sasak during the “Bau Nyale” Festival to generate the creative economy value of the craftman of Lombok weaving

and the rattan handicrafts of Lombok to participate in creating the distinctive products. The architectural solutions to encourage the creative economy in the “Bau Nyale” Festival is proposed the architectural solutions such as: (a) preparing food trucks or used car to maintain the appearance and cleanliness, (b) preparing a camping ground facilities and cooking equipment permanently, (c) water resources facility and toilet, associated with the drainage, (d) waste disposal facilities, (e) Information facilities, (f) wifi access, (g) the culture stage facilities in knock-down to easily installed and removed.

“Left-Right Tracks Parade“ to Visitor Seats

The locale potentially of Sasak is the “Bau Nyale” Festival is contributed by all of Nusa Tenggara Barat province delegates to participate to the Putri Mandalika Competition and held by a Great Parade. It is the embryo of a world class fashion carnival. By learned the success story of the Jember Fashion Carnival (Faris, 2017). He told about his success story to be the international communities of carnival by strengthen the Jember human resources by exploring the mythical legend related the place. So, the storytelling about Princess Mandalika can be leading as the main storylines to the parade by invited the world class of festivals community artist to join annually in Mandalika Resort. To facilitate the event, so Architect proposed the Parade’s Architectural Solutions by design the “Left-Right Tracks Parade“ to provide a comfort zones by created a visitors cover seats non-permanent along the road crossed of the cultural parade.



Figure 1. The artistic status related to *The Princess of Mandalika Legend* (Source: Yuke Ardhiati, 2017).



Figure 2. The artistic Amenity Core of Mandalika Resort Master Plan shows the originally heritage curve of Mandalika based on “uke!” form - a never ending circular shape of the Mandalika Endemic Flower (Source: PT Perentjana Djaja, 2017).

Artificial Intelligence Design Process

The availability of data in the form of photo/ image documentation related to Princess Mandalika to complete the needs of Increased Reality in the form of various properties and characteristics are artifacts that must be informed, such as: statues and monuments, architectural forms, sea atmosphere, building interiors, and so on. At present, these data are stored as part of the Resort Design Guide of PT ITDC which was developed with PT Perentjana Djaja Architect Consultants.

The application of Increased Reality for Indonesian tourism destinations is expected to improve the experience of tourists (who use Google Glass in the future) when traveling. Increased Reality will display in the view of Google Glass users in a visualization, including:

1. "Real" information about the location and features, including comments made by previous visitors from internet access.
2. Allows tourists to experience simulations of historical events, places and objects by making them enter into their visual views.
3. Presenting location information with audio and text (including translators of all languages prepared by Google Translate).

Conclusion

Post the Master Plan of Mandalika Tourist Region of Lombok created by PT Perentjana Djaja Architect, the AI may create to enrich the district. The prospect of the AI project; (a) to create the sacred spot related to the origin of religion of Sasak itself and the legend of Putri Mandalika. By thus the Architect's Team was accommodate the President Joko Widodo's idealist to wish to create "festival for the peoples". They strengthen the Mandalika Resort Master Plan by adopted the heritage tradition "Bau Nyale" Festival as well as the folklore legend "the Princess Mandalika". The legend adopted to be a storyline of the resort a world-class tourist region. (b) The Resort Design Guidelines of Mandalika Resort was adopted the Architecture-Event design approach by accommodated the six criterias. (c) One of the uniqueness of the Mandalika Resort Master Plan is "the Teten of Sasak" Cultural Buffer Zones the resort region guaranty to be a sustainable resort area because of they reduce the disparities between visitors and the locale people of Sasak- Lombok.

References

- Ardhiati, Yuke. (2018). Grounded Theory untuk Arsitektur, Seni dan Desain. Jakarta: Wastu Adicitta
- Ardhiati, Yuke, September 2014. "The Interiority of New Acropolis Museum". In-Arch – Internatioanl Conference 2014, Universitas Indonesia Depok, 11-12 September 2014
- Ardhiati, Yuke, November 2017. "Toward the Tallest Statue Of Garuda Wisnu Kencana: An Exploration of the Architectonic Design of the Land Art of Nyoman Nuarta's Work" . International Journal of Civil Engineering & Technology (IJCIET) Vol 8, Issue 11, pp. 357–367
- Azuma, Ronald T. , August 1997, In Presence: "Teleoperators and Virtual Enviroments A Survey of Augmented Reality" - Hughes Research Laboratories.
- Chu, Yin. (2014). A Review Studies on Luxury Hotels Over The Past in Two Decades. Graduate Theses and Dissertations, Iowa University.
- D.W.F. van Krevelen and R. Poelman, September 2010, "A Survey of Augmented Reality Technologies, Applications and Limitations", The International Journal of Virtual Reality, 2010, 9(2):1-20
- Derrida, J. (2009, 1985), Point de follie – Maintenant l'architecture, 27 avril 2009, accompanying the portfolio Bernard Tschumi, La Case Vide La Villette, 1985, Architectural Association, London
- Fathurrahman, Lalu Agus. (2016). Membaca Arsitektur Sasak. Mataram: Penerbit Genius
<http://citeseerx.ist.psu.edu/viewdoc/download?doi=10.1.1.659.6623&rep=rep1&type=pdf>
<http://lib.dr.iastate.edu/cgi/viewcontent.cgi?article=4920&context=etd>
<https://publikasiilmiah.ums.ac.id/bitstream/handle/11617/.../A7.pdf>
- ITDC of Lombok. (2015). A Visionary Master Plan of The Mandalika Resort. ITDC Lombok
- Kompas 21 Mei 2013: Augmented Reality: Masa Depan Interaktivitas
- Lanier, Jaron, "Who Owns the Future?, You Are Not a Gadget: A Manifesto", Simon & Schuster, Material 2013

- Milgram, P.; F. Kishino (1994). "A Taxonomy of Mixed Reality Visual Displays". IEICE Trans. Information Systems. E77-D (12)
- Rose, Gillian. (2006). Visual Methodologies. An introduction to the Interpretation of Visual Materials. London: SAGE Publications Ltd.
- Scruton, Roger. (1980). the Aesthetics of Architecture. New Jersey: Princenton Essays on the Arts.
- Shneiderman, Plaisant, Cohen, & Jacobs, "Designing the User Interface: Strategies for Effective Human-Computer Interaction". USA : Pearson Education, Inc, 2010
- Strom, Eric. (2003). Regionalism in History, 1890-1945: The Cultural Approach. Journal European History Quarterly, 33 (2), 251-267.
- Tschumi, Bernard.(1997). The Six Concepts of Architecture and Disjunction. MIT Press: Cambridge
- Widya, Leonardo Adi Dharma Widya and Ardhiati, Yuke, August 2013, "Prototipe Desain Visual Realitas Tertambah dengan Kacamata Pintar di Museum Fatahilah", Snete - Seminar Nasional & Expo Teknik Elektro 3, Banda Aceh 2013
- www.augmentingthereality.blogspot.com/2011/02/history-of-augmented-reality.html - (20 Mei 2013)
- www.blog.newsenses.biz/tag/augmented-reality/ - (14 Mei 2013)
- www.icg.tugraz.at/~daniel/HistoryOfMobileAR/ - (20 Mei 2013)
- www.id.wikipedia.org/wiki/Realitas_maya - (14 Mei 2013)
- www.informatika.org/2012/04/augmented-reality-di-belanda-dari-laboratorium-riiset-sampai-proyek-komersial/ - (18 Mei 2013)
- www.inventinginteractive.com - (18 Mei 2013)
- www.istarted.blogspot.com/2013/01/laporan-penulisan-ilmiah.html - (20 Mei 2013)
- www.jaronlanier.com/general.html - (14 Mei 2013) www.jaronlanier.com/general.html - (18 Mei 2013)
- www.kaskus.co.id/thread/5140034ee474b4d71400000d/inilah-cara-kerja-dari-google-glass---getaran-langsung-ke-tengkorak-pengguna - (8 Mei 2013)
- www.neoteo.com/realidad-virtual-en-1957-5380 - (20 Mei 2013)
- www.prehysterics.blogspot.com/2008/07/morton-heilig-sensorama-1962.html - (20 Mei 2013)
- www.tekno.kompas.com/read/2012/05/02/00265964/masa.lalu.kini.dan.masa.depan.tekno
logi.augmented.reality (23 Mei 2013).
- Yulius, H.W.L. Salim. (2013) Kaidah Toponimi. Yunis, Muhammad. 2012. Journal Polingua, Scientific Journal of Linguistic, Literature and Education: "Makna Sebagai Tanda", Universitas Andalas - Fakultas Ilmu Budaya, Vol. 1

Author Information

Yuke Ardhiati

Pancasila University of Jakarta,
Universitas Pancasila Jakarta, 12640, Indonesia.
Contact E-mail: yuke_ardhiati@yahoo.com

The Eurasia Proceedings of Educational & Social Sciences (EPESS), 2019

Volume 13, Pages 155-159

ICRES 2019: International Conference on Research in Education and Science

Comparative Study Based on Quality Indicators of Academic Activities

Silvia VERESIU

“Dunarea de Jos” University of Galati

Elena MEREUTA

“Dunarea de Jos” University of Galati

Madalina Alice RUS

“Dunarea de Jos” University of Galati

Daniel GANEA

“Dunarea de Jos” University of Galati

Valentin AMORTILA

“Dunarea de Jos” University of Galati

Abstract: During the process of quality assurance in education, three subjects are in focus: institutional capacity, educational effectiveness and quality management. Evaluation of the three aspects is done using criteria and standards expressed by performance indicators. Performance indicators are tools for measuring the performance of the university's work in relation to standards. These indicators can vary from the minimum level to the highest. The aim of the paper is to analyze how a quality indicator has evolved, which is related to the evaluation by the university management. Starting from the minimum standards set out in the job description, the percentage of their performance will be determined on the basis of the teachers' annual self-evaluation for the last 10 years. The study focuses on teaching and research on the one hand and managerial activities on the other. Also, on the basis of the analyzed results, we will see what the evolution trend is for the next years.

Keywords: University management, Job description, Quality indicators

Introduction

In the recent years, quality has become a higher education priority in universities. The changes in the labor market, an increase in the number of public or private universities and the development of new curricula and specializations determine employers to request validated official information on the quality of education in the target institutions.

The official recognition is reflected by the accreditation obtained by a university. The National Agency authorized to grant accreditation performs the external evaluation of the quality of the educational process by complying with the existent criteria.

According to "The Methodology of External Evaluation, Standards and the List of Performance Indicators of ARACIS" (<http://www.aracis.ro/>), during the quality assurance process, three issues are under discussion: the institutional capacity, the educational efficiency and the management of quality.

The assessment of these three aspects is performed using criteria and standards expressed by performance indicators. The criteria are the basis of the organization and functioning of the educational institution. The performance indicators are tools for measuring the realization of the activity carried out by the university. These indicators may range from the minimum level to the maximum one.

- This is an Open Access article distributed under the terms of the Creative Commons Attribution-Noncommercial 4.0 Unported License, permitting all non-commercial use, distribution, and reproduction in any medium, provided the original work is properly cited.

- Selection and peer-review under responsibility of the Organizing Committee of the Conference

© 2019 Published by ISRES Publishing: www.isres.org

Teaching Staff Assessment

The evaluation criteria mentioned above are summarized in an evaluation sheet that includes information from four topics: self-evaluation, peer review, student assessment and evaluation of head department.

The self-assessment sheet is drawn up annually and represents a multi-criterion assessment of all teaching and research activities covered in the previous calendar year. The self-evaluation sheet includes two parts:

A. Criteria for assessing didactic and research activities and promotion criteria,

B. Other criteria (professional, administrative, cultural).

Criteria sets A and B are the basis for granting the performance rewards (<http://www.qa.ugal.ro/>).

Completing and presenting the self-assessment sheet according to the deadlines shows that the entire teaching staff has acquired and developed a culture of quality according to the requirements of a total quality management.

At the same time, the criteria of the teacher self-evaluation sheet imply the achievement of standards in the job description. This sheet contains: scores for assessing the teaching and related activities and scores for assessing the scientific research and technological development activities.

The paper aims to study the evolution of the scores recorded for the criteria in the self-evaluation sheet of the teachers from two technical faculties in parallel with the scores imposed by the job description. Also, taking into account the results, developments for the following years will be predicted for these scores.

Recorded Data

For this study the average scores of each teaching staff category from two technical faculties were considered. The scores were normalized so that the number of teachers (time-varying) should not distort the study.

The average scores of each teaching staff category from two technical faculties (using criterion A) are presented in Table 1.

Table 1. Average scores of self-evaluation records – Criterion A

Year	Technical faculty 1				Technical faculty 2			
	Prof.	As.prof.	Lecturer	Assist.	Prof.	As.prof.	Lecturer	Assist.
2009	1304.87	825.00	543.39	289.98	1068.76	337.38	182.17	173.73
2010	2021.07	822.75	610.28	457.68	1902.62	925.18	334.43	466.60
2011	1849.88	923.13	732.14	456.47	1962.90	1116.30	324.80	145.50
2012	1613.29	1000.40	708.81	712.82	2137.18	976.29	548.15	670.64
2013	1139.90	462.64	474.38	327.47	1844.47	770.24	687.98	297.19
2014	1228.53	762.35	492.82	381.20	2193.01	606.93	782.28	455.18
2015	1074.19	791.55	485.31	437.24	2307.80	968.69	806.82	274.09
2016	1184.28	784.38	484.82	515.00	2307.99	1230.81	768.41	350.53
2017	1634.43	562.42	507.00	1072.93	2816.65	1460.47	983.30	1303.44
2018	1875.36	705.25	866.93	446.7	1813.99	1570.63	1141.67	600.87

In Figures 1 and 2 is observed as the scores made by teachers from the two faculties generally exceed the minimum score required by the job description. The percentage of scores in self-assessment sheet versus the maximum required by the job descriptions for professors and assistants are showed in Figures 3 and 4.

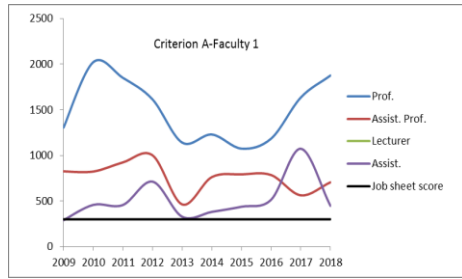

Figure 1. Scores of self-assessment sheet criterion A for faculty 1

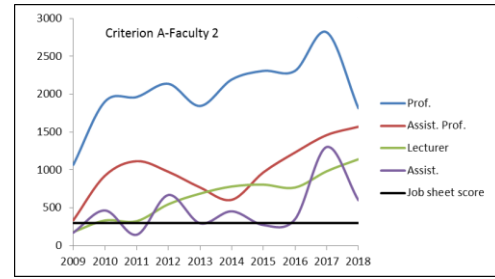

Figure 2. Scores of self-assessment sheet criterion A for faculty 2

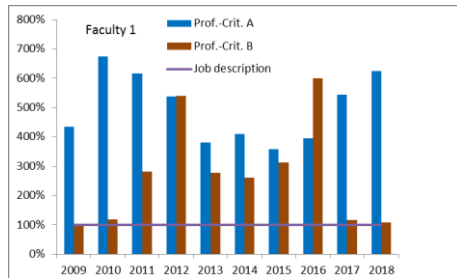

Figure 3. The percentage of scores for A and B criteria for professors - faculty 1

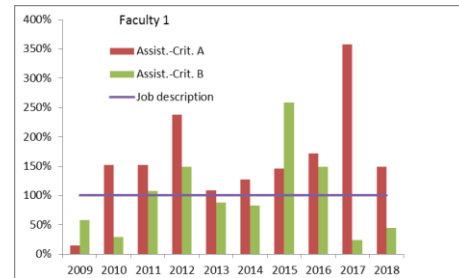

Figure 4. The percentage of scores for A and B criteria for assistants - faculty 1

The average scores of each teaching staff category from two technical faculties (using criterion B) are presented in Table 2.

Table 2. Average scores of self-evaluation records – Criterion B

Year	Technical faculty 1				Technical faculty 2			
	Prof.	As.prof.	Lecturer	Assist.	Prof.	As.prof.	Lecturer	Assist.
2009	308.14	127.50	144.02	175.06	318.81	169.07	180.38	160.85
2010	355.55	201.29	171.23	87.48	370.17	227.17	182.14	219.25
2011	847.33	565.25	177.53	322.60	981.3	274.80	183.30	265.00
2012	1619.70	769.76	309.17	446.79	1602.47	330.70	274.92	245.84
2013	835.38	315.75	320.90	263.98	625.10	153.33	260.42	168.25
2014	780.43	206.43	293.30	250.17	659.01	211.21	310.92	256.57
2015	935.47	157.19	201.78	775.05	796.40	281.38	789.58	299.63
2016	1799.71	230.66	295.98	448.00	965.33	572.50	222.61	332.75
2017	348.90	143.27	190.58	70.75	481.49	262.92	267.40	222.13
2018	321.77	137.16	228.87	133.75	370.23	199.97	240.61	325.25

In Figures 5 and 6 it can be noticed that the scores made for criterion B by teachers and lecturers in the two faculties exceed in general the minimum score imposed by the job description, while the lecturers and assistants are below the score in the job sheet. The explanation is that the latter, being more concerned with developments in the teaching career, becoming more involved in scientific research.

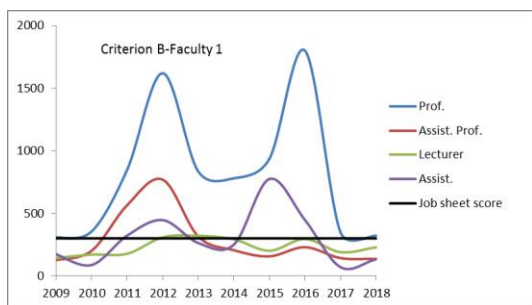

Figure 5. Scores of self-assessment sheet criterion B for faculty 1

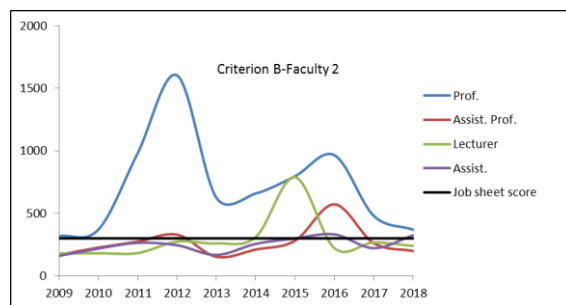

Figure 6. Scores of self-assessment sheet criterion B for faculty 2

Research Method

A statistical instrument was used as research method: the moving average (Biji, 2012). This method was used to analyze the collected data between 2009 and 2018. The annual scores were systematized and thus time series were generated.

The moving average method consists of calculating the seasonal component of time series by dividing the trend to total successive values of the series. The method is used when a time series shows fluctuations, in order to smooth the evolution. The moving average method aims at highlighting the central tendency of evolution of a phenomenon. The method is characterized by elasticity, the ability to easily adjust to new conditions. Using regression the basic trend of evolution of the studied phenomenon is established, by cancelling large fluctuations, which may distort real evolution.

The averages are called mobile because constantly the first term of the previous average is deleted, while the next term is added. Thus, based on average annual recorded scores from self-assessment files, criterion A, seasonal component, irregular component and the trend component were calculated and the combination of them determined the forecast for the next three years (Veresiu, 2017).

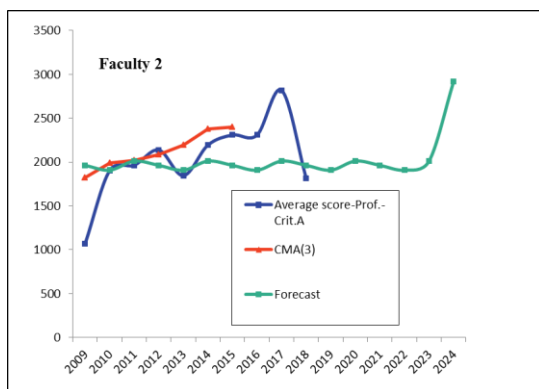

Figure 7. Forecast of professors' average scores criterion A for faculty 2

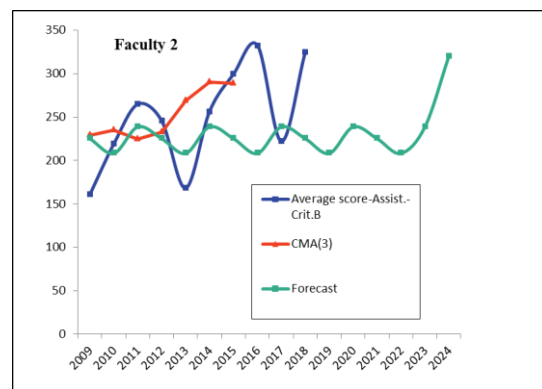

Figure 8. Forecast of assistants' average scores criterion B for faculty 2

The data were computed using the moving average method. The Figures 7 and 8 show the historical evolution of average scores, the center moving average (CMA) (the baseline) and the forecast for the following five years, for two categories of teaching staff from the faculty 2.

The intermediate results showed that it is possible to emphasize the seasonality irregularity components, to reveal the seasonality component and to predict the future trends for the average score, getting rid of irregularities and seasonality.

It is noted that the trend for the following years is to increase the scores recorded in the self-evaluation sheet. The same analysis can be performed for all categories of teaching staff.

Conclusion

1. Starting from the minimum standards set out in the job description, the percentage of their performance was determined on the basis of the teachers' annual self-evaluation for the last 10 years.
2. For forecasting a statistical methods was used, namely the moving average method. The analysis can be performed for all categories of teaching staff.
3. On the basis of the forecasts provided by the moving average method, measures can be established to improve the didactic and related activities for each category of teaching staff.

References

- <http://www.aracis.ro/proceduri/>
<http://www.qa.ugal.ro/index.php?page=evaluare>

Biji, E., et al., (2012). *Statistică pentru economiști*, Ed. Economică, Bucuresti.

Veresiu, S., Mereuta, E., Rus, M., Ganea, D., Amortila, V., (2017). *Forecast of a quality indicator in academic activity using statistical methods*, 21st Innovative Manufacturing Engineering & Energy International Conference – IManE&E 2017, DOI: <https://doi.org/10.1051/mateconf/201711208008>

Author Information

Silvia Veresiu

“Dunarea de Jos” University of Galati
Str. Domneasca, nr. 47, Galati, 800008, Romania
Contact E-mail: silvia.veresiu@ugal.ro

Elena Mereuta

“Dunarea de Jos” University of Galati
Str. Domneasca, nr. 47, Galati, 800008, Romania

Madalina Rus

“Dunarea de Jos” University of Galati
Str. Domneasca, nr. 47, Galati, 800008, Romania

Daniel Ganea

“Dunarea de Jos” University of Galati
Str. Domneasca, nr. 47, Galati, 800008, Romania

Valentin Amortila

“Dunarea de Jos” University of Galati
Str. Domneasca, nr. 47, Galati, 800008, Romania

Towards the Design of a Didactic Engineering Relying on Economy as a Semiotic Model of Mathematics

Pierre JOB

Pancasila University of Jakarta

Jean-Yves GANTOIS

Ichec Brussels Management School

Abstract: Teaching mathematics, in a business and management school, led us to investigate the use of economy as a way to give alternative meaning to mathematical concepts, whether these concepts were already known to students - mostly from secondary school - or not. The intent behind this idea was to reverse the traditional connection between mathematics and economy. We tried to bridge the increasing gap between what students coming from secondary school are really capable of, irrespective of their grades, and what is expected from them in a business and management school. Instead of mathematics seen as a tool for economy, where mathematical theories are simply “applied” to economy, we developed an engineering where economy is used as a semiotic model of mathematics. Therefore, mathematics is not “applied” anymore to economy, it rather becomes consubstantial to economy, both disciplines acting on each other. This paper presents the structure of this engineering, the underlying hypothesis and the didactic motivations behind it.

Keywords: Engineering, Semiotic model, Economy, Mathematics, Transition

Introduction

This paper presents a didactic engineering designed for first year students entering a university level cursus in economy, business and management. This engineering hasn't been tested yet. The focus will be on exposing and justifying one of its principle, the use of economy as a semiotic model of mathematics. To carry out this plan we first need to explain the context in which this engineering started to grow.

Context

We are teaching in a Belgian high-school (university level) in economy, business and management and in charge of the same mathematical course given to 600 first year students, for more than six years. This course is the first at university level for most of our students. It underwent many changes over the years. Not for the sake of change but because of high failure rates. We had to face failure rates between 50% and 75% for the last six years. This was unacceptable for us and thus tried to reduce them using many different measures. Some measures were designed at the level of our institution or even by the minister of education. For instance:

- methodology courses are part of the curriculum (students learn how to study, take notes, ...);
- a student only needs 10 out of 20 to pass an exam;
- under some circumstances, a student is allowed to access the following year without passing one or more exam, he can still pass them in the following years.

Others measures were devised over the years by the teachers in charge of the course. This means us and other colleagues. We are currently the only teachers in charge but it hasn't always been the case in the past (see below). Here are a few examples of “inside” measures.

- This is an Open Access article distributed under the terms of the Creative Commons Attribution-Noncommercial 4.0 Unported License, permitting all non-commercial use, distribution, and reproduction in any medium, provided the original work is properly cited.

- Selection and peer-review under responsibility of the Organizing Committee of the Conference

- Decreased number of students in groups.
- Up to 5 teachers in charge of the course, thus more teachers per student.
- Less theory and more exercises.
- Course mostly stripped down from proof/demonstrations.
- Only a few theorems left.
- Detailed solutions to exercises to help students understand the way we want them to write down solutions.
- New exercises very similar to previous ones.
- Bonus points when doing some exercises.
- Improved explanation based on recurring errors.
- Exams based on questions solved almost “as is” during the course.
- Exam questions simplified over the years.
- A few weeks before the exam, preparation given to students, very similar to exam questions.

This is only a sample of the many directions we investigated. One measure that played a special role for us is the “reminder strategy”. At some point, the course content was almost entirely based on reminders from secondary school: almost no new concepts were introduced. At that time, we choose to do so because we had to face the fact that our students didn’t have the most basic skills, we taught we required to follow our course. For instance, many of them have trouble simply adding fractions, or computing the slope of a line. What kind of mathematics can you do when the most basic requirements are not fulfilled and the idea you have of mathematics is to teach within the framework of a deductive architecture, where knowledge is built onto one another? All these measures didn’t seem to have much impact: failure rates remained the same. This gave rise to a deep questioning of the way we envisioned the teaching of mathematics and most notably of the reminders strategy that we taught was unavoidable. The first question we addressed was why were all these measures ineffective, especially the reminders one?

The Platonic-Formalist Epistemology

We dug into the subject and found no easy answer to that question. Only a complex web of causes. We will not detail all these causes. Rather, we will single out one of them, that led us to adopt the principle underlying our engineering. This cause is the weight high-level cultural/epistemological constraints bear on the possible shape a mathematical course can take on (Chevallard,1992). In Job & Gantois (2017), we investigated the idea that « hidden » cultural/epistemological constraints deeply impact the possible structure of a mathematical course. In Belgium, many teachers have been raised in a specific epistemology: the platonic/formalist one. Roughly speaking, this epistemology relies on two postulates. The first one is that mathematical concepts reside somewhere in “mathematical heaven”. The only way to get in touch with these concepts is through intuition. You either have it (mathematical intuition) or not. However fruitful, intuition can nevertheless be misleading. This leads to a second postulate. Mathematics have to be cast into a strictly deductive mould whose aim is to avoid the pitfalls of intuition. It means that, in the end, deductive reasoning is the only really relevant level of rationality that can be used to convey genuine mathematics.

Consequences on the Educational System

This epistemology has deep consequences on the educational system. Many teachers are at a loss when facing students that do not remember/understand key concepts. Being driven by the deductive architecture of mathematics they tend, at a local level, to repeat over and over again the same bribe of deductive reasoning. This leads, when passing from one class to the next, to the reminders strategy. If a student doesn’t understand mathematics at some point it must be because he doesn’t understand or recall past pieces of the deductive architecture, those pieces he needs to rely on, at this stage of the learning process. Understanding mathematics is reduced to the way they are expressed in a deductive way (Bourbakism). For many teachers, the possibility of understanding functions of multiple variables without going through the theory of one-variable functions is dubious. They are at a loss when they have to face the fact that some students are able to pass an exam about very “abstract” concepts like the theory of categories when they struggle to pass a first-year exam dealing with limits, integrals, ... When the reminders/repeating strategy fails (and it does), teachers are sort of forced into relying on the heavy use of charts, graphics, gestures to make their point. This process can go so far that the meaning of mathematics gets lost in the process (Brousseau, 2002). Teachers have a hard time envisioning the design of a course based on a different level of rationality than the deductive one (Schneider, 2010). This leads

to failure like the counter-reformation of mathematics with mathematical courses mostly stripped down from their deductive architecture with not much else to replace it (Rouy, 2007).

Reducing Economy to Mathematics

Another consequence of the platonic/formalist epistemology is that economy (and other sciences) are often reduced to an application of mathematics. Being mathematized becomes a criterion of scientificness. We won't debate about the soundness of that criteria and focus on the didactic aspect. Let us simply note that not all economists agree with that kind of subordination (de Vroey, 2002). One major experimental drawback of reducing economy to mathematics is that students do not understand the link between economy and mathematics when "applying" mathematics to economy. For instance, simply stating, as an application of the theory of lines, that $2x+5y=100$ is the budget line of two goods with unit costs of 2 and 5 euros given a budget of 100 euros, x and y being the respective quantities of the goods that can be bought, is so obvious, that it becomes meaningless for many students. They do not understand why so much credit is given to budget lines. There is no problem to which the "budget line" would constitute an instrumental answer. From a certain angle the budget line is deprived of economic meaning. It is just a line that has been coloured with economic painting. We feel there is a sharp difference between a mathematical course filled with economic references and one which really relies on economy to build mathematics on top. Despite its economic labelling, the budget line lacks epistemological density.

Relying on Economy

In contrast, in Job & Gantois (2018), we related the conclusion of a promising experience. Students were able to give meaning to inequalities like $ax+by\leq c$ using an economic context and relate them to half planes, again using economy as a semiotic guide. This conclusion is of great importance because, on the contrary, trying to teach them that $ax+by\leq c$ could be seen as a half-plane, in the sole setting of mathematics, failed for years. This experimental background led us to devise an engineering that would get rid of reminders and, instead, be structured with the idea that it is feasible to build mathematical concepts, in a way meaningful for students, starting from economic problems, and giving these concepts meaning through economy. In other words, we have argued the soundness of using "economy as a semiotic model of mathematics". Our arguments are based on experimental facts structured by an epistemological model (the platonic-formalist epistemology). Let us now turn to the structure of our engineering and see how the principle "economy as a semiotic model" shapes it.

A course Centered around Techniques and Classes of Problems

Reminders have been replaced by economic optimisation problems which form the core of the engineering. It should be stressed that we are not simply building a course around (more or less isolated) problems. In this sense, our approach is not a generic problem-based engineering, where we solely rely on "solving problems and everything else will come out naturally". These problems have a specific structure. They belong to the same class of problems we shall call C. This class is composed of problems asking to optimise a linear function of two variables, subjected to one linear constraint. Students are given problems taken from C but without being explicitly told that these can be considered as instances of the same class. They are simply faced with problems to solve. Moreover, these problems are not given in a formal way: there is no mention of linear functions or any formal object whatsoever. All these problems are expressed in casual language. Here is one example. Every other problem goes along the same lines.

Two goods A_1 and A_2 are given.
 A_1 is sold at a price of 10€ per unit.
 A_2 is sold at a price of 15€ per unit.
 A_1 requires per unit the use of 2 units of another good U .
 A_2 requires per unit the use of 5 units of U .
The quantity of U at hand is limited to 523 units.
Which quantity of each A_1 and A_2 will maximize the profit subject to the limitation on U ?

These problems have been chosen so that economy can be used to solve them. It means that no mathematical technique is forced upon the students right from the start. Enough problems of C are provided to students so they can devise their own technique T to solve them. To students, these problems might not be as trivial as it

may appear to the reader. Devising one single technique is expected to happen as a process. Let us briefly develop this aspect. One technique T_1 that should be expected from students is to simply produce as much as possible of the good that has the highest price. This technique is working on some instances, but not on every instance, as is the case of the example given above. Indeed A_1 only uses 2 units of U compared to 5 units for A_2 , it means that the each unit of U invested in A_1 has a return of $10/2=5$ euros, whereas A_2 only has a return of $15/5=3$ euros. Thus, producing as much as possible of the good having the lowest price is more profitable in this case. This can serve as the basis for another technique T_2 . Moreover, the question of using entirely or not the quantity c of U at hand is not completely trivial. For instance, if the goods you are selling are rings, you cannot always use all of c simply because you cannot sell a fraction of a ring. This peculiar case may also bring about another technique T_3 that takes this specificity into account. Other aspects might be disturbing for the students but only an experiment could settle the matter. What we want to emphasize here is that these problems being new to students, up to a certain point, each new instance is susceptible to require a new technique to be solved or at least may require to amend an existing one. So, at first, the students will more likely develop a set of techniques T_1, T_2, \dots, T_k to solve the problems. Only when enough of these problems are given, will they have the opportunity to get rid of less efficient techniques and gradually build a more powerful one, T , integrating the different aspects of the problems. We can reasonably expect the following T to emerge from the various problems studied by the students. You choose to produce as much as possible of the good that has the greatest profitability i.e. the good which gives you the greatest benefit for each unit of U used in building that good. Then, if there are still units of U left, you complete your production with as much units as possible of the other good. Let us note that T is very much rooted in economic with its profitability concept. This anchoring into economy allows students to justify technique T and how sound it can be without being experts in “traditional” mathematical proof: there is no need for a sophisticated formal proof. This can be considered as the first step towards students edifying a theory. As even more problems are given to students, the question “Do you want to endlessly repeat the same calculations for each new problem or do you want to solve them, once and for all, using a general model of the problems?” will become an interesting issue, that will put them in a position where it becomes meaningful for them, to design a model of the problems they are given, on which they could apply T to solve all instances at once. In this case, the model will simply consist in replacing the various objects of the problems by letters, each having a specific status: variables, constants, unknown,...

Two goods A_1 and A_2 are given.

A_1 is sold at a price of p_1 € per unit.

A_2 is sold at a price of p_2 € per unit.

A_1 requires per unit the use of u_1 units of another good U .

A_2 requires per unit the use of u_2 units of U .

The quantity of U at hand is limited to c units.

Which quantity q_1 and q_2 of each A_1 and A_2 will maximize the profit subject to the limitation on

U ?

In this model

A_1, A_2 are just labels and not numbers, they are not constants nor unknowns nor anything of that sort.

p_1, p_2, u_1, u_2, c are constants

q_1, q_2 are unknowns

This is where C comes into explicit existence for the students, under the guise of an algebraic model and not just as a collection of problems that implicitly belong to the same class. This step will most likely be no small business for our students, as most of them struggle with letters and even more when it comes to distinguish between the various status of a letter. Once again, economy can be used to clarify the various status, based on previous numerical instances of the model. Thus, from the student point of view, qualifying the above model as a model is plainly relevant as it requires a conceptual effort to uses letters the proper way. The emergence of C then allows the students to apply T to the “abstract” algebraic model to solve all the problems falling under that model. Applying T to solve the model requires to express T in the language of the model and calls for a recast like the following. Let us define the profitability r_i of good A_i as the ratio p_i/u_i and q_i^* the amount of A_i that maximizes the profit. Given those notations, T can be expressed as follows. If $r_i \geq r_j$, produce as much as possible of A_i and then as much as possible of A_j with the possible remains, that is $q_i^* = \lfloor c/u_i \rfloor$ and $q_j^* = \lfloor (c - q_i^* u_i) / u_j \rfloor$. This last stage constitutes a new step towards the creation of a theory. Students now have at their disposal an algorithm to solve problems from C and the justification to it. To sum up, C and T emerge in a dialectic process, each one acting on the other, those interactions being regulated through economic means.

Conclusion

We have presented, explained and justified a principle on top of which a didactic engineering, aimed at first year students, in a university level school of business, economy and management, is built. This principle amounts to using economy to give meaning and develop mathematical concepts useful in solving economic problems. The idea underlying this principle is to reverse the somewhat common scheme of “economy as a mere application of mathematics” into “mathematics forged in the crucible of economy”. This idea emerged from our observations in classrooms and thus stems from an experimental background. Those observations were allowed by the epistemological reading grid, the platonic-formalist epistemology, we developed studying the reasons why measures taken to counteract high failures rates were ineffective. Thus, the principle and structure of our engineering relies on a didactic model rooted both in experimentation and theoretical epistemology. Given this cross-breeding nature, it took us quite some time to develop this engineering. We haven’t been able to test it in classrooms yet. Further experimentations are required to inform us about the ecological viability of our engineering and the soundness of the underlying hypothesis. We intend to do so in the coming years taking all the necessary precautions. Indeed, another reason worth mentioning is that our engineering is a rather large scale one. It is designed to fit an entire course. From an institutional perspective, we cannot afford to turn it into a complete failure with students not diving into it. To us this makes a huge difference with respect to engineering that were “only” experimented at a much smaller scale with not much impact on the global ecology of a course. In other words, it is a much less risky business to experiment an engineering on a few selected students outside the beaten path of regular courses than an engineering impacting 600 first year students for their first course at university level.

References

- Brousseau, G. (2002), *Theory of Didactical Situations in Mathematics*, Netherlands: Springer.
- Chevallard, Y. (1992). Concepts fondamentaux de la didactique : perspectives apportées par une approche anthropologique. *Recherches en Didactique des Mathématiques*, 12(1), 73-112.
- de Vroey, M. (2002). La mathématisation de la théorie économique : le point de vue de l'histoire des théories économiques. *Reflets et perspectives de la vie économique*, 4(41), 9-20.
- Job, P., & Gantois, J.-Y. (2017). High level constraints weighting on the possible shapes knowledge can take on. In M. Shelley M., M. Pehlivan (Ed.), *Education Research Highlights in Mathematics in Science and Technology 2017* (pp. 14-20). Ames, IA: ISRES Publishing.
- Job, P. and Gantois, J.-Y. (2018) Investigating economy as a mean to rejuvenate fossilized mathematical knowledge. *The Eurasia Proceedings of Educational & Social Sciences (EPESS)*, 10, 248-253.
- Rouy, J. (2007). Formation initiale des professeurs de l’enseignement secondaire supérieur et changements de rationalité mathématique entre l’institution secondaire et l’institution universitaire. Le cas éclairant du thème des dérivées (Doctoral dissertation). Université de Liège, Liège.
- Schneider, M. (2010), *Traité de didactique des mathématiques : la didactique par des exemples et contre-exemples*, Liège : Presses Universitaires de Liège.

Author Information

Pierre Job

Ichec Brussels Management School
Boulevard Brand Whitlock 4,
1150 Woluwe-Saint-Pierre
Belgique
Contact E-mail: pierre.job@ichec.be

Jean-Yves Gantois

Ichec Brussels Management School
Boulevard Brand Whitlock 4,
1150 Woluwe-Saint-Pierre
Belgique

8th Grade Kemalism and Revolution History Textbook Investigation of Social Studies Teacher Candidates' Opinions

Ozkan AKMAN
Gaziantep University

Mustafa Murat CAY
Gaziantep University

Abstract: Textbook, written in a training program, content, teaching-learning process, prepared in accordance with the assessment criteria of measurement and printed instruction used for learning purposes It is material. A well-prepared textbook is of great benefit to both teachers and students. It also guides teachers and students in the textbook, educational and learning activities. The textbook of the Ministry of National Education, Textbook Regulation; defines the subjects which will be used in all kinds and degrees of formal and non-formal education institutions, prepared in accordance with the curriculums. In addition to the benefits mentioned above, textbooks; on the one hand, the students determine what they will learn, while on the other hand they determine what teachers will teach. In other words, a textbook is a material in both the learning and teaching process. Because of such an important educational tool, the textbooks cause a lot of criticism. Nevertheless, developing technological tools; Although textbooks of computers, tablets and smartphones pass the development of textbooks, textbooks are still an indispensable element in our lives and education. the purpose of this study; 8th Republic of Turkey Kemalism and Revolution History textbook shape, form, constitution and legislation in terms of compliance with the views of social studies teacher candidates to examine. The design of the research was done by using the technique of document analysis. According to the results obtained in the study, the constitution, legislation and form in terms of form they generally considered sufficient. The best used textbooks in the education process will affect everyone in the education process positively. Therefore, it is necessary to correct the missing parts and the most perfect textbooks.

Keywords: Revolution history, Textbook

Introduction

Textbooks are the most widely used teaching tool of the learning-teaching process. Today, the place of textbooks in the classroom is still important and teachers carry out many activities with books. Most teachers make arrangements for learning-teaching activities according to their textbooks without looking at the curriculum. Therefore, the importance of textbooks is increasing. Course books are one of the basic tools of education and training and they are of great importance in terms of fulfilling the social, social, economic and individual development functions undertaken by our schools. Textbooks are basic documents that examine and explain the information related to the subjects in the curriculum in a planned and organized manner, directing and educating the students in line with the objectives of the course. Textbooks are the basic tools used in a course and play a role in the development of that course in the process, in the course of knowledge and practice, or in the expansion of that course. They have the characteristic of being a permanent product with high labor and functional value in terms of their continuous supervision feature in their preparation and regulation, the large number of processes they undergo on maturation and development, and their meticulous and meticulous work necessity qualities (Güçlü et al., 2001). The textbook appeared for the first time in Ancient Egypt in 4000 BC on mathematics, medicine, and plane geometry drawn and written on papyrus roll (Kaya, 2002; Tekişik, 1986). A textbook is a book prepared or selected in relation to the teaching of a course. In a similar sense, it is a book that is recommended as a basic resource for teachers and students for a particular school, class and course after being examined according to certain measures (Oğuzkan, 1993). The textbook covers tested and proven

- This is an Open Access article distributed under the terms of the Creative Commons Attribution-Noncommercial 4.0 Unported License, permitting all non-commercial use, distribution, and reproduction in any medium, provided the original work is properly cited.

- Selection and peer-review under responsibility of the Organizing Committee of the Conference

information (Kula, 1988). As we have seen, textbooks have a significant impact on what students learn and what teachers will teach during teaching.

Textbooks are especially important in primary education. Primary education is an initial period in the liking of reading and acquiring good reading habits. For this reason, the quality of books to be written and published for primary school children comes to the forefront (Kılıç, Atasoy and Others, 2001). In this context, the textbook, indispensable visual and most used tools of the teaching-learning process (Demirel, 1999). On the other hand, students can participate more actively when they read the textbooks and come to class as a preparation.

Indeed, the important contribution of the textbook to the achievement of the purpose of a course cannot be denied. Textbooks are sources that influence what teachers will teach, while determining what students will learn. However, they are perhaps the most criticized educational tools. We can easily say that there are some problems related to the textbooks used by students and teachers (Gümüş, 2004).

Books allow the teacher to use his power better and present it more systematically in teaching; however, the teacher should know that the book should not be a prisoner. In this context, the teacher of the class is not the author of the book itself. Teachers can offer one or more books to their students about their courses; however, the books to be offered to the students should be interesting. Students enjoy reading books written in everyday language, with short sentences and paragraphs, decorated with appropriate pictures. Asking students to provide books that they cannot easily find or buy will make them difficult. Books are also very useful materials for students. Thanks to the book, the student has the opportunity to repeat what the teacher tells at any time, anywhere and at any pace (Küçükahmet, 2000).

The basic principle in the preparation of textbooks in the teaching process; the behavior of books determined in the curriculum; knowledge, skills and features of the students to include activities and guidance activities. Books should be able to provide learning experiences to the student and guide them. This can be achieved by directing students to as many different activities as possible. To draw attention and interest of the students at the beginning of the subject or unit in the textbooks, to prepare them by making them willing, to present the learning experiences in the process of gaining the behavior while the unit is in progress and to provide control and reinforce the control at the end of the unit, and to reach certain results by itself. opportunity should be given (Kaptan, 1999).

Textbooks should be student-centered. The principles of program development should be followed in the writing of the books and the books should have aesthetic values in every aspect. The information and methods in the books should be up to date and new researches should be included. The books should reflect the real problems of the society, the teaching method should be student-oriented, and the individual should be able to recognize himself (Pingel, 2003).

In this study; History of the Republic of Turkey and Atatürk is to examine textbooks in accordance with the opinion of the teachers. For this purpose, the following sub-problems were sought.

1. Has the Turkish Revolution History and Kemalism textbook been prepared in accordance with its purpose?
2. Is the Turkish History of Turkish Revolution and Kemalism textbook content appropriate?
3. Is the History of Turkish Revolution and Kemalism textbook sufficient in terms of language and expression?
4. How is the textbook of Turkish Revolution History and Kemalism visually?

Method

In this study, content analysis method which is thought to be suitable for our purpose was used. Because content analysis is to bring together similar data within the framework of certain concepts and themes and interpret them in a way that the reader can understand (Yıldırım & Şimşek, 2006). Content analysis is a systematic, reproducible technique in which some words of a text are summarized in smaller content categories with codings based on certain rules.

Data Collection Tools

Research data 4. taught middle school social studies teachers in the Republic of Turkey and Atatürk History of the textbooks are composed of investigation from a variety of variables.

Data Analysis

Data analysis was subjected to content analysis. In this study, 4 sub-problems were distributed to 8 groups and 1 sub-problem was distributed to each group. Each group examined the sub-problem textbook in which they were responsible, and in the first stage, coding was made according to predetermined concepts (screening and selection criteria) and themes were obtained in this context. The data was then edited, grouped by themes, and, where appropriate, findings presented. Finally, the findings obtained were interpreted.

Results

Findings for the first sub-problem

Has the Turkish Revolution History and Kemalism textbook been prepared in accordance with its purpose? The question of the textbook; It is seen that the textbook is durable and easy to use, that the book is aesthetic, that it is free from printing errors, that there is a cover arrangement suitable for the content of the course, that schema type tools are provided to help the students to make a connection between the part they read and the whole. However, it was observed that the bibliography is not up to date and there are no margins on the pages to facilitate reading and taking notes.

Findings for the second sub-problem

Is the History of Turkish Revolution and Atatürkism textbook appropriate in content? The question of the textbook; It is consistent with national, moral, cultural and human values, the content is free from unnecessary detail and excess information, the general structure of the book, the basic principles of Turkish National Education, Atatürk's principles and revolutions, meaningful links with other disciplines are established, the content of the sections, units and a reasonable balance between the subjects in terms of volume and appropriate to the curriculum. However, it was observed that the texts were not sufficiently enriched with examples, and that the practices that would enable the textbook students to reveal similarities and differences between geographical events and spaces were not given enough space.

Findings for the third sub-problem

Is the Turkish Revolution History and Kemalism textbook sufficient in terms of language and expression? The question of the textbook; In the text; correct, clear, comprehensible language and expression were used and Turkish spelling rules were observed. However, it is also seen that some texts are not suitable for the development level of the students.

Findings for the fourth sub-problem

What is the history of Turkish Revolution and Kemalism textbook visually? The question of the textbook; It is seen that visual tools (maps, photographs, tables, figures, diagrams, etc.) are adequately included, prints of visual tools are clear, clear, aesthetic and understandable, and necessary explanations are made regarding visual tools. However, it is also seen that visual tools are not placed in suitable places in a way that allows easy comprehension of texts.

Conclusion and Recommendations

Textbooks are an indispensable source of countries. Therefore, as a result of the examination and evaluation of textbooks, an orientation towards higher quality books should be provided. In this study, when the form, content, language and expression are examined visually, it is seen that there are pros and cons in the light of the findings. Textbooks; it should be designed to enable education and training within the scope of the curricula and meet the textbook standards of developed countries. Exercise books with plenty of visual elements should be

prepared. The texts should be arranged in such a way as to encourage the student to learn more, to examine, to research and to refer to other sources. A style that directly addresses the student should be followed. When the student reads the text, he / she should be able to sense that he / she is being addressed. Detailed narration should be avoided and narrative should be plain. Lean expression should be preferred without using unnecessary words.

References

- Güçlü, N., Topses, G., Yel, S., Korkmaz, A., Çakmak, M., Köksal, H., & Albayrak, F. (2001). Hayat Bilgisi 1-3, Konu Alanı Ders Kitabı İnceleme Kılavuzu (1. basım). *Ankara: Nobel Yayın Dağıtım*.
- Kaya, Z. (2002). *Uzaktan eğitim*. Pegem A Yayıncılık.
- Tekışık, H. H. (1986). Ders Kitabı Nedir, Seçimi Nasıl Olmalı?. *Çağdaş Eğitim Dergisi*, 11(110), 1-3.
- Oguzkan, F. (1993). Eğitim terimleri sözlüğü. *Ankara: Emel Matbaacılık*.
- Kula, O. B. (1988). Ders kitabının yapımında gözetilen bilim, kuramsal ve didaktik çerçeve. *ÇÜ Eğitim Fakültesi Dergisi*, 2(1), 2.
- Kılıç, Z., Atasoy, B., Tertemiz, N., Şeren, M., & Ercan, L. (2001). Fen bilgisi 4-8, konu alanı ders kitabı inceleme kılavuzu. *Ankara: Nobel Yayın Dağıtım*.
- Demirel, Ö. (1999). Öğretme sanatı. *Ankara: Pegem Yayınları*.
- Gümüş, E. (2004). Ortaöğretim coğrafya ders kitaplarına bir bakış. *HAYEF Journal of Education*, 1(1).
- Küçükahmet, L. (2000). *Öğretimde planlama ve değerlendirme*. Nobel Yayın Dağıtım.
- Kaptan, F.(1999): Fen Bilgisi Öğretimi, İstanbul: Millî Eğitim Basımevi.
- Pingel, F., (2003), Ders Kitaplarını Araştırma ve Düzeltme Rehberi, Tarih Vakfı Yayınları, İstanbul.
- Yıldırım, Ş. (2006). Yıldırım A. & Şimşek H.(2006). *Sosyal bilimlerde nitel araştırma yöntemleri*, 5.

Author Information

Ozkan Akman

Gaziantep University,
Nizip Faculty of Education
Contact E-mail: akmanozkan@email.com

Mustafa Murat Cay

Gaziantep University,
Nizip Faculty of Education

An Investigation of How to Refer Doing Statistics in 8th Grade Mathematics Textbooks

Nadide YILMAZ

Karamanoğlu Mehmetbey University

Abstract: Textbooks should provide suggestions for teaching the content and helping students learn big ideas related to concepts being covered (Tarr, Reys, Barker & Billstein, 2006). Since textbooks were used frequently by teachers for covering the key points of the lesson the study recommended that textbooks should have some requirements (Son, 2008; Stodolsky, 1989). The requirements should satisfy the learning objectives of the educational system (MoNE, 2018a). One of the learning domain which include the learning objectives to be taught to students in mathematics textbooks was data handling (MoNE, 2018b). Data handling included doing statistics: the process of formulating questions, collecting, analyzing, and interpreting data to help make decisions in everyday life (NCTM, 2000). The purpose of this study was to investigate the data handling sections of the 8th grade mathematics textbook which are used in MoNE schools in the 2018-2019 school year. It was also evaluated in terms of how involve doing statistics process. For the purposes of the study, a document analysis was used. In order to analyze the data, content analysis was used. The findings of this study depicted that textbooks are inadequately encouraging students in doing statistics process. Furthermore, it was observed that the textbooks aren't cover focusing conceptual connections sufficiently.

Keywords: 8th grade mathematics textbooks, Data handling, Doing statistics

Introduction

Textbooks are thought to serve as an important source providing guidance for teachers about what to teach and how to teach it and how to evaluate their students as well (Alajmi, 2009; Haggarty & Pepin, 2002; Hirsch, Lappan, Reys, & Reys, 2005). Moreover, they have an important role in providing learning opportunities for students in the way of learning mathematics (Fan, 2013; Houang, Wang, Wiley, Cogan & Wolfe, 2001; Schmidt, McKnight, Houang, Wang, Wiley, Cogan & Wolfe, 2001; Weinberg & Wiesner, 2010; Wijaya, van den Heuvel-Panhuizen, & Doorman, 2015). Another remarkable point is that textbooks have an important influence on classroom works and constitute the backbone of math instruction (Kajander & Lovric, 2009; Törnroos, 2005). It is stated that textbooks are the most common source used in the learning process both in our country and in the world (Arslan & Özpınar, 2009; Aydoğdu İskenderoğlu & Baki, 2011; Beaton, Mullis, Martin, Gonzalez, Kelly, & Smith, 1996; Grouws & Smith, 2000; Johansson, 2005; O'Sullivan, 2017; Törnroos, 2005; Weiss, Banilower, McMahon & Smith, 2001). The findings obtained from international exams also support this belief and show that teachers use mathematics textbooks as the main source when selecting teaching methods (Mullis, Martin, Foy & Arora, 2012). Research shows that secondary school math teachers use textbooks at the most (Grouws & Smith, 2000; Weiss ve diğerleri, 2001). As they support teachers and teaching, textbooks can be said to be an integral part of mathematics education. Due to the fact that textbooks have a direct impact on the concept to be selected by teachers and on the decisions made by teachers in relation to how to teach this concept, the role of textbooks becomes more critical (Reys, Reys, & Chavez, 2004). Fan and Kaeley (2000), in their study examining the impact of textbooks on teaching strategies, found that textbooks can affect not only the content of teachers' lessons but also how teachers actually teach. At the same time, math textbooks affect what subjects are covered and how these subjects are presented (Yang & Sianturi, 2017) because it is unlikely to be presented in class when a subject is not covered in the textbook (Alajmi & Reys, 2007). In this context, textbooks are expected to reflect the current curriculum in full (Ubuz, Erbaş, Çetinkaya & Özgeldi, 2010) because it can be said that the textbooks serve as a bridge between curriculum designers and the teacher (Valverde, Bianchi, Wolfe, Schmidt & Houang, 2002). It is also emphasized that textbooks are closer to

- This is an Open Access article distributed under the terms of the Creative Commons Attribution-Noncommercial 4.0 Unported License, permitting all non-commercial use, distribution, and reproduction in any medium, provided the original work is properly cited.

- Selection and peer-review under responsibility of the Organizing Committee of the Conference

the classroom environment than the curriculum (Howson, 1995). This once again demonstrates the need for the textbooks to reflect the knowledge and skills targeted in the curriculum.

Data processing is a learning area which is emphasized in both primary and secondary school mathematics curriculums and aims to equip students with various knowledge and skills at each class level (MONE, 2018b). It is stated that this learning area should be structured to take into account the process of doing statistics in the teaching process (MONE, 2018b; Van de Walle, Karp & Bay-Williams, 2012). It is emphasized that the data teaching should be carried out on the basis of the processes of creating a searchable question, collecting data, processing and analyzing the data and interpreting the results (MONE, 2018b). Textbooks should also be designed to take these processes into account. Therefore, it is aimed to examine how the 8th grade mathematics textbooks which have been found to be suitable for teaching in the 2018-2019 academic year include the process of doing statistics.

Method

In the current study, qualitative research method was adopted and document analysis was used. Document analysis is a method that allows the examination of written and visual materials about the subject of interest (Yıldırım and Şimşek, 2011). Answer is sought to the problem of interest by conducting a detailed inspection of the materials (Corbin and Strauss, 2008; Glenn, 2009). The sections related to the data processing learning area in the 8th grade mathematics textbooks approved to be studied in the 2018-2019 academic year were examined. In the Education Information Network, two 8th grade mathematics textbooks were found and these textbooks were coded as Textbook A and Textbook B (Böge & Akıllı, 2018; Kişi, 2018). The explanations, activities, questions and examples included in the textbooks were analyzed using content analysis within the context of doing statistics (forming searchable questions, collecting data, processing and analyzing the data and interpreting the results). The content analysis focuses on summarizing the information at hand according to certain contents and presenting it to the reader (Cohen, Manion & Morrison, 2007). The data related to the data processing learning area of the 8th grade mathematics textbooks were analyzed within the context of the above-mentioned themes and then are presented to the reader.

Results and Discussion

When the explanations in the introduction parts of the textbooks were examined, it was found that the explanations in the introduction part of the textbook A support the process of making statistics while the explanations in the introduction part of the textbook B are structured in such a way as to bring the data representation capacity of graphs to the fore (Figure1, 2).

Verilerin Grafik ile Gösterimi

Deney, gözlem veya anket sonucunda elde edilen verilerin temsil edilmesi (gösterilmesi) için kullanılan nokta, şekil, resim veya çizgilere **grafik** denir.

Grafikler, ekonomide, meteorolojide ve fen bilimlerinde sıkça kullanılır. Grafikler, sayısal verileri görsel hâle getirerek onları daha hızlı anlamamızı sağlar. Veriler arasındaki ilişkileri ve bir verinin bütün veri grubu içindeki yerini görerek birtakım sonuçlara ulaşmamıza yardımcı olur. Bu sonuçlara dayalı olarak tahminde bulunmamızı sağlar.

Verilerin gösteriminde amaca yönelik çeşitli grafik türleri kullanılabilir.



Figure 1. Textbook B

Neden Öğrenmeliyiz?

Veri analizi, temelini matematikten alan bir bilim dalıdır. İstatistik, verileri toplama ve toplanan verileri düzenleme, analiz etme, yorumlama, objektif ve doğru kararı verme ile ilgili bilimsel ve teknik metotlar geliştiren ve uygulayan bir bilim dalıdır. Veri analizini reklam, kamuoyu yoklamaları, güvenilirlik tahminleri, nüfus değişim eğilimleri, sağlık riskleri, öğrencilerin okul başarıları, ürün satışlarının yıllara göre dağılımı, imalathanelerde üretilen ürünlerin miktarları, bir şehrin yıllara bağlı olarak aldığı yağış miktarlarındaki değişim, ülkeler arasındaki üretim karşılaştırmaları, bir internet sitesine bir günde giren insan sayısının incelenmesi gibi pek çok alanda kullanılmaktadır.

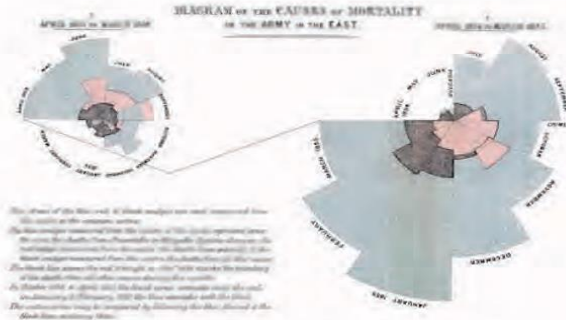

Flornce Nightingale tarafından tasarlanan grafik.



Flornce Nightingale

1850'li yıllarda, Kırım Savaşı'nda İngiliz ordusundaki yaralı askerlere bakmak üzere İstanbul Selimiye Kışlası'nda kurulan askeri hastaneye gönderilen Florence Nightingale (Filorens Naytingeyl), hastanenin bakımsız olduğunu ve insanların savaş yaralarından çok sıtma ve çeşitli bulaşıcı hastalıklar nedeniyle öldüğünü tespit etmiştir.

Flornce Nightingale, bu nedenle çalıştığı hastanenin şartlarını iyileştirmek için çeşitli çalışmalar yapmıştır. Yaptığı çalışmalarda özellikle veri analizinden yararlanmış, gözlemlediği eksiklikleri grafiğe dönüştürerek bir veri grafiği oluşturmuştur. Hastanenin temiz ve bakımlı olması gerektiğini söyleyerek generalleri ve politikacıları bu konuda harekete geçirmiştir.

Bugünkü modern hastanelerin Nightingale'nin veri analizlerinden yararlanarak şartlarını iyileştirdiğini söyleyebiliriz.

Figure 2. Textbook A

It is observed that the explanations about the graphs in the textbook B are structured in such a way as to emphasize the elements of graphs. Moreover, there are explanations mentioning the functions of graphs (Figure 3).

Bilgi

Verilerin yatay ve dikey eksenlerin oluşturduğu düzlemde bir nokta ile gösterildikten sonra bu noktaların birleştirilmesiyle elde edilen grafik türüne **çizgi grafiği** denir.



Bilgi

Yatay ve dikey eksenlerin oluşturduğu bir düzlemde, verilerin dikdörtgenlerle gösterildiği grafik türüne **sütun grafiği** denir. Sütun grafiğinde dikdörtgenlerin (sütunların) genişlikleri eşittir. Sütunlar arasında eşit uzunlukta boşluklar bulunur.

! Uyarı

Çizgi grafiği, verilerdeki değişimin gösterilmesi için en uygun grafik türüdür.

Figure 3. Textbook B

It has also been revealed that the explanations in the textbook A are structured in such a way as to put greater emphasis on the functions of graphs (Figure 4).

Bunu Öğrenelim

Çizgi grafiği, bir olayın zaman içerisinde nasıl değiştiğini göstermek için kullanılan bir grafik türüdür. Çizgi grafiğinde değişkenler sürekli olmalıdır. Örneğin zamana göre hava sıcaklığındaki değişim, zamana göre bir aracın yakıt tüketimindeki değişim ya da bir aracın aldığı yolun zamana göre değişimi ve bir ağacın zamana göre boyundaki uzama miktarı çizgi grafiği ile gösterilir.

Bunu Öğrenelim

Bir veriyi grafiğe dönüştürürken grafiklerin aşağıdaki özelliklerinden yararlanılır.

Daire grafiği, bir bütünün parçaları hakkında bilgi vermek için kullanılan bir grafik türüdür.

Sütun grafiği, verilerin karşılaştırılması için kullanılan bir grafik türüdür.

Çizgi grafiği, belli bir zaman aralığındaki sürekli değişimin gözlenmesinde kullanılan bir grafik türüdür.

Figure 4. Textbook A

While some place is allocated to giving information about how to draw graphs in the textbook A, no information is given about the drawing of graphs in the textbook B (Figure 5, 6).

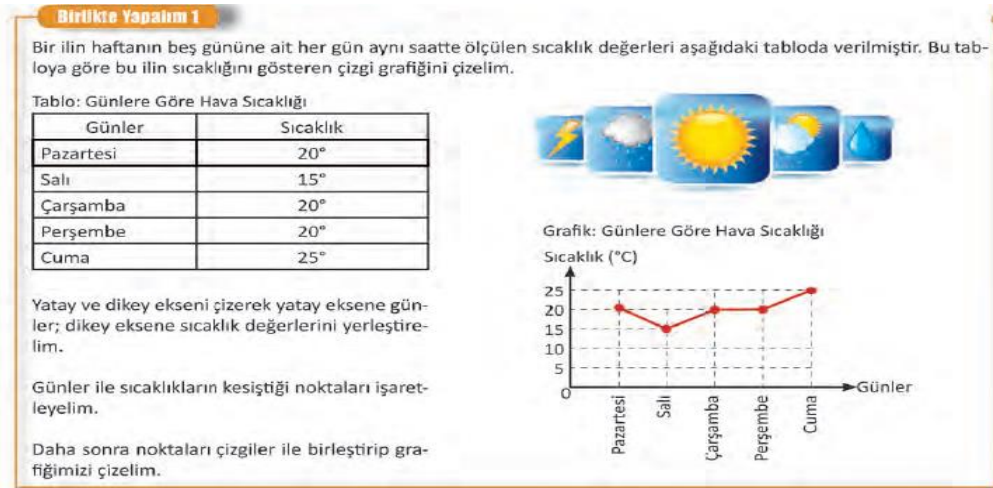

Figure 5. Textbook A

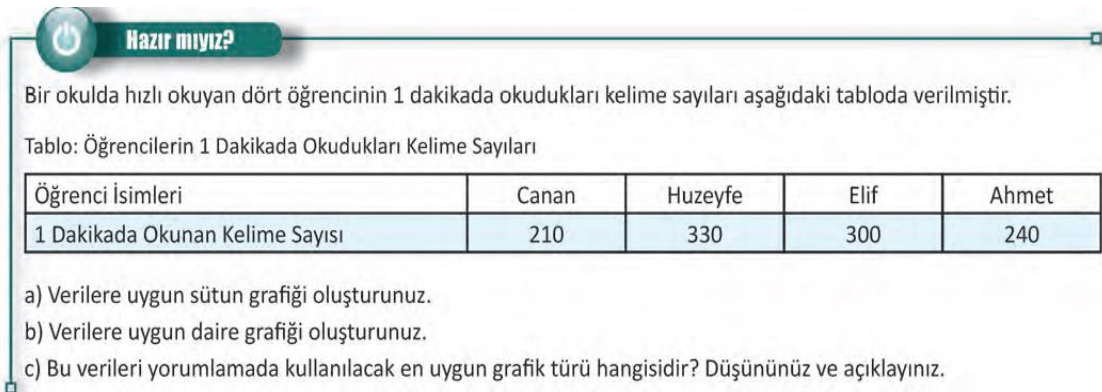

Figure 6. Textbook A

Although both textbooks have included information about the interpretation of graphs, it has been revealed that there is no information about how to relate these interpretations to the research question. Moreover, the interpretations were found to be directed to between the data interpretations while beyond the data

interpretations are not presented. On the other hand, the interpretations made were found to be in such a way as to bring the function of graphs to the fore (Figure 7,8).

Örnek

Yandaki tabloda bir otomobilin 5 saatlik süre içinde zamana bağlı olarak aldığı yol verilmiştir. Otomobilin zamana bağlı olarak aldığı yolu çizgi grafiği ile göstererek grafiği yorumlayalım.

Tablo: Otomobilin aldığı yol

Zaman (sa.)	1	2	3	4	5
Yol (km)	75	150	150	175	200

Çözüm

Tablodaki verilere göre (1, 75), (2, 150), (3, 150), (4, 175), (5, 200) sıralı ikililerine karşılık gelen noktaları düzlemde gösterelim. Bu noktaları yandaki gibi birleştirelim.

Otomobilin zamana bağlı olarak aldığı yoldaki değişimi aşağıdaki gibi açıklayabiliriz.

- Otomobil 1 ve 2. saatler içinde yetmiş beşer kilometre yol almıştır.
- Otomobil 2 ile 3. saat arasında hareket etmemiştir.
- Otomobil 4 ve 5. saatler içinde yirmi beşer kilometre yol almıştır.
- Otomobilin hızı ilk iki saat içinde en yüksek değerdedir.

Grafik: Otomobilin aldığı yol

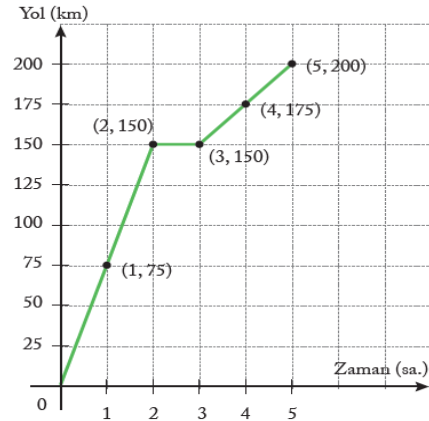

Figure 7. Textbook B



Sıra Sizle 6

Hayvan barınakları, sokak hayvanlarının sağlıklı beslendiği ve korunduğu yerlerdir. Bu gibi yerlerin oluşturulmasında sokak hayvanlarına yardım eden hayvanseverlerin ve sivil toplum kuruluşlarının önemi büyüktür.

Yandaki grafikte, A, B ve C hayvan barınaklarındaki hayvan sayıları gösterilmektedir.

Buna göre aşağıdaki soruların çözümünü altlarındaki boşluklara yapınız.

a) Barınaklarda hangi hayvan türünün sayısı en fazladır?

b) C barınağındaki köpek sayısı A barınağındaki köpek sayısından kaç eksiktir?

Grafik: A, B ve C Barınaklarındaki Hayvan Sayıları

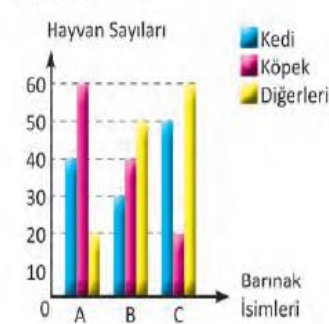

Veri Analizi

Figure 8. Textbook A

It was observed that the given activities and examples are not shaped around a context. The section giving information about what type of graph is appropriate to use within the framework of the formulated question is incomplete (Figure 9).

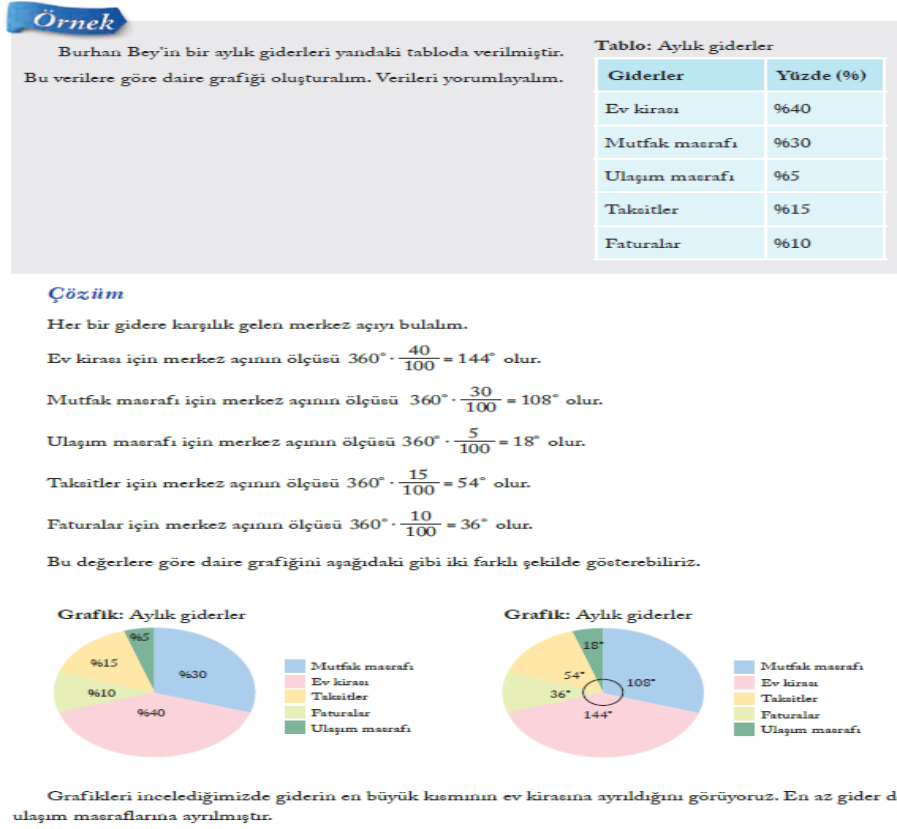

Figure 9. Textbook B

As shown in the example above, it is not clear why the data should be shown with a pie chart. This might result in students' making overgeneralization. Students might conclude that when it is %, then the pie chart must be used. In addition, it was observed that the part of associating with the formulated question is incomplete. A similar situation was observed in the textbook A. In the explanations given below, it is observed that there is an explanation indicating that the appropriate graph type should be decided only on the basis of data type. Though this statement is not false, it is incomplete (Figure 10).

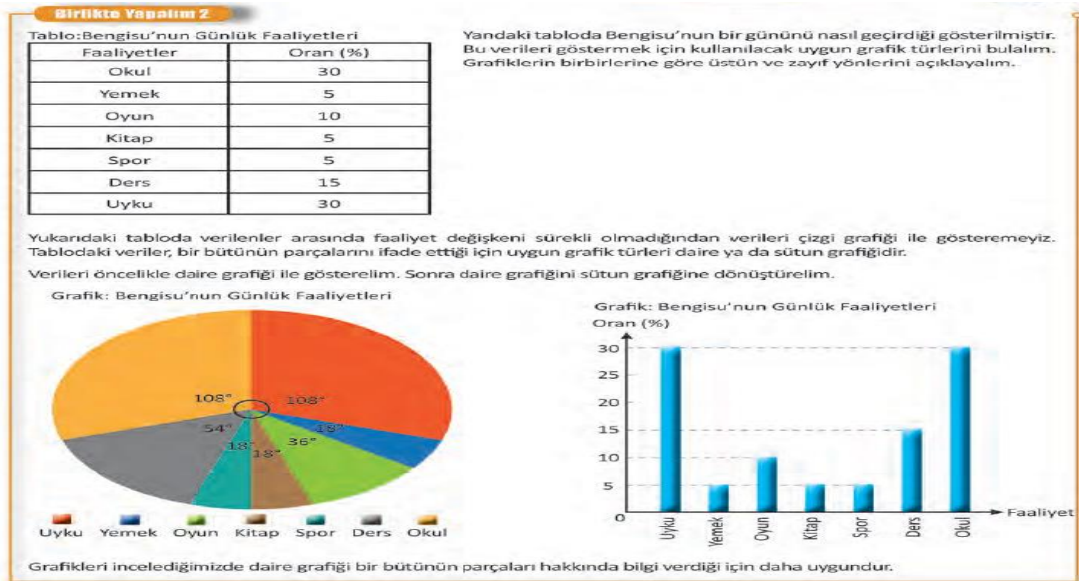

Figure 10. Textbook A

A similar situation was observed in the part related to the selection of the most appropriate type of graph. It is not clear why pie, line and bar charts were selected in the part explaining how the most appropriate graph should

be selected. It is not explained that this selection should be made depending on the formulated question (Figure 11).

Örnek

Bir otomobil galerisinde satılan A ve B marka araçların dört yıllık satış miktarları aşağıdaki eşlik tablosunda gösterilmiştir. Bu verilerin gösterimi için en uygun grafik türünü belirleyerek çizelim.



Tablo: Araçların satış miktarları

Yıllar	A	B
2011	20	15
2012	25	20
2013	30	20
2014	35	30

Çözüm

Veriler için en uygun grafik, ikili sütun grafiğidir.

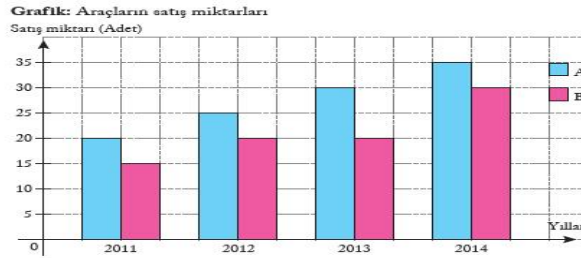

Grafiği incelediğimizde A marka aracın satışının giderek arttığını görüyoruz. B marka aracın satışının ise dört yıllık süre içinde azalmadığını söyleyebiliriz.

Figure 11. Textbook B

In the above given example, it is stated that the most suitable graph is the bar chart. Yet, it is not explained how this has been decided. In another example, though explanations are made about the different functions of graphs, it is not explained what kind of role these functions play; that is, the direct connection with the formulated question is not explained (Figure 12).

Örnek

Bir hava yolu şirketinin yıllara göre taşıdığı yolcu sayısı yandaki çizgi grafiğinde verilmiştir. Bu verileri sütun ve daire grafiği ile gösterebiliriz.

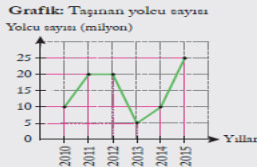

Grafik: Taşınan yolcu sayısı
Yolcu sayısı (milyon)

Çözüm

Çizgi grafiğini incelediğimizde yandaki tabloyu oluşturabiliriz. Tabloyu incelediğimizde 2010 - 2015 yılları arasında toplam 90 milyon yolcunun taşındığını görürüz. Bu verilere göre aşağıdaki sütun grafiğini oluşturabiliriz.

Verileri daire grafiği ile göstermek için 2010 - 2015 yılları arasındaki yolcu sayılarına karşılık gelen merkez açıların ölçülerini bulalım.

2010 için $\frac{10}{90} = \frac{x}{360}$ orantısından merkez açının ölçüsü $x = \frac{10 \cdot 360}{90} = 40^\circ$ olur.

2011 için $\frac{20}{90} = \frac{x}{360}$ orantısından merkez açının ölçüsü $x = \frac{20 \cdot 360}{90} = 80^\circ$ olur.

2012 için $\frac{20}{90} = \frac{x}{360}$ orantısından merkez açının ölçüsü $x = \frac{20 \cdot 360}{90} = 80^\circ$ olur.

2013 için $\frac{5}{90} = \frac{x}{360}$ orantısından merkez açının ölçüsü $x = \frac{5 \cdot 360}{90} = 20^\circ$ olur.

2014 için $\frac{10}{90} = \frac{x}{360}$ orantısından merkez açının ölçüsü $x = \frac{10 \cdot 360}{90} = 40^\circ$ olur.

2015 için $\frac{25}{90} = \frac{x}{360}$ orantısından merkez açının ölçüsü $x = \frac{25 \cdot 360}{90} = 100^\circ$ olur.

Bu değerlere göre yandaki daire grafiğini çizebiliriz. Dikkat edilirse yıllara göre taşınan yolcu sayıları arasındaki farklar sütun grafiğinde, yolcu sayıları arasındaki oran ise daire grafiğinde daha açık görülmektedir.

Tablo: Taşınan yolcu sayısı

Yıllar	Yolcu sayısı (milyon)
2010	10
2011	20
2012	20
2013	5
2014	10
2015	25

Grafik: Taşınan yolcu sayısı
Yolcu sayısı (milyon)



Grafik: Taşınan yolcu sayısı
Yolcu sayısı (milyon)

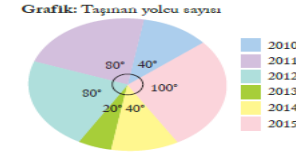

Figure 12. Textbook B

A similar situation is observed in the textbook A (Figure 13,14).

Sıra Sizde 3

Aşağıdaki tabloda, bir aracın 4 aylık benzin ve LPG kullanım miktarları verilmiştir. Tablodaki verilerin en uygun hangi grafik türü ile gösterilebileceğini bulunuz ve belirlediğiniz grafik türüne göre bir çizim yapınız.

Tablo: Aylara Göre Benzin - LPG Miktarları (L)

Aylar	1. Ay	2. Ay	3. Ay	4. Ay
Benzin	10	12	8	5
LPG	50	60	45	70





Figure 13. Textbook A

Birlikte Yapalım 5



Bir ortaokulun öğrencileri, "Oksijenimiz Tükenmesin" adlı bir proje ile ağaç dikme etkinliği düzenlemiştir. Aşağıda verilen tabloda, etkinliğe katılan sınıflardaki öğrencilerin diktikleri fide türleri ve sayıları gösterilmiştir. Buna göre verileri en uygun şekilde temsil eden grafiği çizelim.

Tablo: Dikilen Fide Türleri ve Sayısı

Fide Türleri / Sınıflar	5. Sınıflar	6. Sınıflar	7. Sınıflar	8. Sınıflar
Çam	40	80	50	70
Çınar	60	30	50	60

Tablodaki veriler arasında karşılaştırma yapıldığı için en uygun grafik türü sütun grafiğidir.

Grafik: Çam ve Çınar Ağacı Diken Öğrenci Sayılarının Sınıflara Göre Dağılımı

Ağaç Sayısı

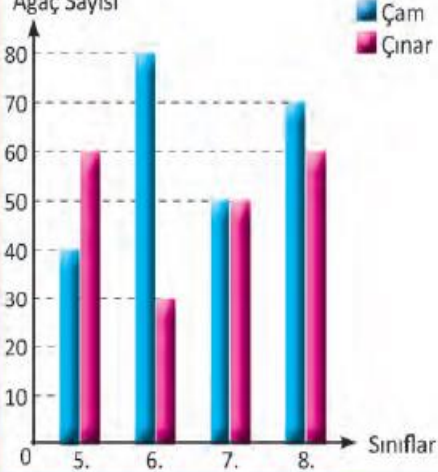

Sınıflar

Figure 14. Textbook A

Conclusion and Recommendations

In this study, it was investigated how the doing statistics process of the explanations, questions and examples in the data processing learning area is addressed in the secondary school 8th grade mathematics textbooks approved to be studied in the 2018-2019 academic year. For this purpose, two 8th grade textbooks were

analyzed and evaluated according to the statistics making process emphasized in the secondary school mathematics curriculum (MONE, 2018b). Both of the textbooks were found to be deficient in terms of inclusion of the process of doing statistics. When the explanations in the introduction parts of the textbooks were examined, it was revealed that the explanations in the introduction part of the textbook A support the process of making statistics while the explanations in the introduction part of the textbook B are structured in such a way as to bring the data representation capacity of graphs to the fore. It is observed that the explanations about the graphs in the textbook B are structured in such a way as to emphasize the elements of graphs. It has also been revealed that the explanations in both of the textbooks are structured in such a way as to put greater emphasis on the functions of graphs. While some place is allocated to giving information about how to draw graphs in the textbook A, no information is given about the drawing of graphs in the textbook B. Although both textbooks have included information about the interpretation of graphs, it has been revealed that there is no information about how to relate these interpretations to the research question. Moreover, the interpretations were found to be directed to reading between the data interpretations while reading beyond the data interpretations are not presented. On the other hand, the interpretations made were found to be in such a way as to bring the function of graphs to the fore. It was observed that the given activities and examples are not shaped around a context. The section giving information about what type of graph is appropriate to use and when within the framework of the formulated question is incomplete. This can be argued to result in some difficulties and misconceptions for students (e.g., when it is percentage, a pie chart is always used; the temperature variable is always represented with a line graph). Furthermore, though explanations are made about the different functions of graphs in both of the textbooks, it is not explained what kind of role these functions play; that is, the direct connection with the formulated question is not explained. In the curriculum, it is emphasized that data processing learning area should be addressed on the basis of the doing statistics process (MONE, 2018b). Thus, it can be suggested that textbooks should be structured in such a way as to take this process into consideration.

References

- Alajmi, A. H. (2009). Addressing computational estimation in the Kuwaiti curriculum. Teachers' views. *Journal of Mathematics Teacher Education*, 12, 263–283.
- Alajmi, A., & Reys, R. (2007). Reasonable and reasonableness of answers: Kuwaiti middle school teachers' perspectives. *Educational Studies in Mathematics*, 65(1), 77–94.
- Arslan, S. & Özpınar, İ. (2009). İlköğretim 6. sınıf matematik ders kitaplarının öğretmen görüşleri doğrultusunda değerlendirilmesi. *Dicle Üniversitesi, Ziya Gökalp Eğitim Fakültesi Dergisi*, 12, 97-113.
- Aydoğdu-İskenderoğlu, T. & Baki, A. (2011). İlköğretim 8. sınıf matematik ders kitabındaki soruların PISA matematik yeterlilik düzeylerine göre sınıflandırılması, *Eğitim ve Bilim*, 36(161), 287-301.
- Beaton, A. E., Mullis, I. V., Martin, M. O., Gonzalez, E. J., Kelly, D. L., & Smith, T. A. (1996). Mathematics achievement in the middle school years: IEA's third international mathematics and science study (TIMSS). Boston, MA: Center for the Study of Testing, Evaluation, and Educational Policy, Boston College.
- Böge, H. & Akıllı, R. (2018). *Ortaokul ve İmam Hatip Ortaokulu Matematik 8. Sınıf ders kitabı*, Devlet Ders kitapları, Ankara.
- Cohen, L., Manion, L., & Morrison, K. (2007). *Research Methods in Education*. London: Routledge/ Falmer.
- Corbin, J., & Strauss, A. (2008). *Basics of Qualitative Research (3rd ed.):Techniques and Procedures for Developing Grounded Theory*. Thousand Oaks, CA: Sage Publications.
- Fan, L. (2013). Textbook research as scientific research: Towards a common ground on issues and methods of research on mathematics textbooks. *ZDM Mathematics Education*, 45(5), 765-777.
- Fan, L. & Kaeley, G. S. (2000). The influence of textbooks on teaching: An empirical study. *Mid-Western Educational Researcher*, 13(4), 2–9.
- Glenn A. B., (2009) Document Analysis as a Qualitative Research Method, *Qualitative Research Journal*, 9(2), 27-40.
- Grouws, D. A. & Smith, M. S. (2000). Findings from NAEP on the preparation and practices of mathematics teachers. In E. A. Silver & P. A. Kenney (Eds.), Results from the Seventh Mathematics Assessment of the National Assessment of Education. National Council of Teachers of Mathematics.
- Haggarty, L., & Pepin, B. (2002). An investigation of mathematics textbooks and their use in English, French and German classrooms: who gets an opportunity to learn what? *British Educational Research Journal*, 28(4), 567-590.
- Hirsch, C., Lappan, G., Reys, B., & Reys, R. (2005). Curriculum as a focus for improving school mathematics. *Mathematicians and Education Reform Forum Newsletter*, 18(1), 1-14.
- Howson, G. (1995). *Mathematics textbooks: A comparative study of grade 8 texts*. Vancouver: Pacific Educational Press.

- Johansson, M. (2005). Mathematics textbooks - the link between the intended and the implemented curriculum. Paper presented to "the Mathematics Education into the 21st Century Project" Universiti Teknologi, Malaysia. http://math.unipa.it/~grim/21_project/21_malasya_Johansson119-123_05.pdf, Retrieved from 2 February 2019.
- Kajander, A. & Lovric, M. (2009). Mathematics textbooks and their potential role in supporting misconceptions. *International Journal of Mathematics Education in Science and Technology*, 40(2), 173-181.
- Kişi, E. (2018). *Ortaokul ve İmam Hatip Ortaokulu Matematik 8. Sınıf ders kitabı*, Ekoyay, Ankara.
- Ministry of National Education (MoNE) (2018a). Taslak kitap incelemesinde esas olacak ölçütler. http://emufredat.meb.gov.tr/Dokumanlar/inceleme Kriterleri_30032018.pdf, Retrieved from 20 February 2019.
- Ministry of National Education (MoNE) (2018b). *Matematik Dersi Öğretim Programı (İlkokul ve Ortaokul 1, 2, 3, 4, 5, 6, 7 ve 8. Sınıflar)*. Ankara, Türkiye.
- Mullis, I.V.S., Martin, M.O., Foy, P., & Arora, A. (2012). TIMSS 2011 international results in mathematics. Chestnut Hill, MA: TIMSS & PIRLS International Study Center, Boston College.
- NCTM (2000). *Principles and standards for school mathematics*. Reston, Va.: NCTM.
- O'Sullivan, B. (2017) *An analysis of mathematical tasks used at second-level in Ireland*. PhD thesis, Dublin City University, Ireland.
- Reys, B. J., Reys, R. E., & Chávez, O. (2004). Why mathematics textbooks matter. *Educational Leadership*, 61(5), 61-66
- Schmidt, W. H., McKnight, C. C., Houang, R. T., Wang, H. C., Wiley, D. E., Cogan, L. S., Wolfe, R. G. (2001). *Why schools matter: A cross-national comparison of curriculum and learning*. San Francisco, CA: Jossey-Bass.
- Son, J. (2008). *Elementary teachers' mathematics textbook use in terms of cognitive demands and influential factors: a mixed method study*. Unpublished Doctoral Dissertation. Michigan State University, Michigan.
- Stodolsky, S. S. (1989). Is teaching really by the book? In P.W. Jackson & S. Haroutunian-Gordon (Eds.), *From Socrates to software*, 88th Yearbook of the National Society for the Study of Education (pp. 159-184). Chicago, IL: University of Chicago Press.
- Tarr, J. E.; Reys, B. J.; Barker, D. D.; & Billstein, R. (2006). Selecting high quality mathematics textbook, *Mathematics Teaching in the Middle School*, 12(1), 50-54.
- Törnroos, J. (2005). Mathematics textbooks, opportunity to learn and student achievement. *Studies in Educational Evaluation*, 31(4), 315-327.
- Ubuz, B., Erbaş, A.K., Çetinkaya, B. & Özgeldi, M. (2010). Exploring the Quality of the Mathematical Tasks in the New Turkish Elementary School Mathematics Curriculum Guidebook: the Case of Algebra. *ZDM Mathematics Education*, 42, 483-491.
- Weinberg, A., & Weisner, E. (2010). Understanding mathematics textbooks through reader-oriented theory. *Educational Study in Mathematics*, 76(1), 49-63.
- Weiss, I. R., Baniower, E. R., McMahan, K. C., & Smith, P. S. (2001). *Report of the 2000 national survey of science and mathematics education*. Chapel Hill, NC: Horizon Research, Inc.
- Wijaya, A., Van den Heuvel-Panhuizen, M., & Doorman, M. (2015). Opportunity-to-learn context-based tasks provided by mathematics textbooks. *Educational studies in Mathematics*, 89, 41-65.
- Yang, D., Sianturi, I. A. (2017). An Analysis of Singaporean versus Indonesian Textbooks Based on Trigonometry Content. *Eurasia Journal of Mathematics, Science and Technology Education*, 13(7), 3829-3848.
- Valverde, G. A., Bianchi, L. J., Wolfe, R. G., Schmidt, W. H., & Houang, R. T. (2002). *According to the book: Using TIMSS to investigate the translation of policy into practice through the world of textbooks*. Dordrecht, Netherlands: Kluwer Academic Publishers.
- Van de Walle, J. A., Karp, K. S., & Bay-Williams, J. M. (2012). *Elementary and middle school mathematics: Teaching developmentally*. New Jersey: Pearson Education.
- Yıldırım, A. & Şimşek, H. (2011). *Sosyal Bilimlerde Nitel Araştırma Yöntemleri* (8. Baskı). Ankara: Seçkin Yayıncılık.

Author Information

Nadide Yılmaz

Karamanoğlu Mehmetbey University

Karaman/Turkey

Contact E-mail: nadideylmz20@gmail.com

The Eurasia Proceedings of Educational & Social Sciences (EPESS), 2019

Volume 13, Pages 179-183

ICRES 2019: International Conference on Research in Education and Science

Dynamics of Human Resources in a Composite University Future Trends

Madalina RUS

“Dunarea de Jos” University of Galati

Elena MEREUTA

“Dunarea de Jos” University of Galati

Silvia VERESIU

“Dunarea de Jos” University of Galati

Daniel GANEA

“Dunarea de Jos” University of Galati

Valentin AMORTILA

“Dunarea de Jos” University of Galati

Abstract: The human resource has an important role both at the scale of society as a whole and in every organization. The key to success in ensuring the competitiveness of the organization in a competitive market is to organize and manage staff so as to enable the creative potential of the human resource to be maximized. Due to the large number of universities in Romania (over 100) and in the field of higher education there is competition, so we can talk about the competitive market. The diversity of the student and teacher profile, the effect of technologies and the globalization of the economy influence the provision of educational services offered by universities. Teachers' structure is important because it provides information on the career development of the human resource. In this paper, the authors propose to analyze and anticipate the dynamic of the structure of the teaching staff employed in a composite university. The data are obtained from the university's own database and statistically processed. According to the results, dynamic teaching staff employed in such an university, shows different trends depending on the faculty profile.

Keywords: Competitiveness, Teachers' structure, The career development

Introduction

Under the conditions of the present social-economic environment, quality has become both a strategic tool of management and a determinant of competitiveness. The quality of the products / services offered is an essential factor in the service of civil society and the environment. Due to the large number of universities in Romania and in the field of university education one can speak of a competitive market. Long-term success will have universities that will be able to attract as many students as possible and will be internationally visible through scientific research.

Generating and transferring knowledge to society through initial training and continuing education at university and postgraduate level, for the purpose of personal development, professional insertion of the individual and satisfaction of the need for competence of the socio-economic environment is also the mission of the university analyzed in this study.

The structure of academic staff on teaching positions can be considered an important indicator in measuring the evolution of the quality of human resources in the system, as well as the capacity of the system to attract young people interested in the activity in the university environment (www.edu.ro).

- This is an Open Access article distributed under the terms of the Creative Commons Attribution-Noncommercial 4.0 Unported License, permitting all non-commercial use, distribution, and reproduction in any medium, provided the original work is properly cited.

- Selection and peer-review under responsibility of the Organizing Committee of the Conference

© 2019 Published by ISRES Publishing: www.isres.org

From this perspective, the purpose of this study is to analyze the distribution of teaching positions in a composite university.

Method

University studied is a comprehensive university of 14 faculties that offer training to specialists with higher education, science and culture, health, technical, economic, legal and social activities. The paper analyzes the distribution of teaching positions during 2011-2019 per component faculty and their evolution is estimated for the next five academic years. For the analysis were considered data recorded on the university's own platform at the beginning of each academic year studied.

Statistical data processing allowed the analysis and estimation of the evolution of the number of teaching positions at university level (Mereuta, 2006). For estimating the evolution of the number of teaching positions in the next five academic years the moving average method was used (Veresiu, 2017).

Centralized data per academic year and teaching positions can be found in the table (Table 1) below:

Table 1. Distribution of teaching positions per university

	Prof.	Assoc. Prof.	Lect.	Assist.	Total positions
2011-2012	150	239	553	247	1189
2012-2013	155	253	440	178	1026
2013-2014	161	256	428	224	1069
2014-2015	168	236	393	224	1021
2015-2016	189	237	408	219	1053
2016-2017	196	240	410	195	1041
2017-2018	201	257	397	200	1055
2018-2019	188	261	419	214	1082

Results and Discussion

After centralizing the results on the university, it is noticed that the lecturers' positions have the highest share while the professors' positions are the smallest (Figure 1, Figure 2).

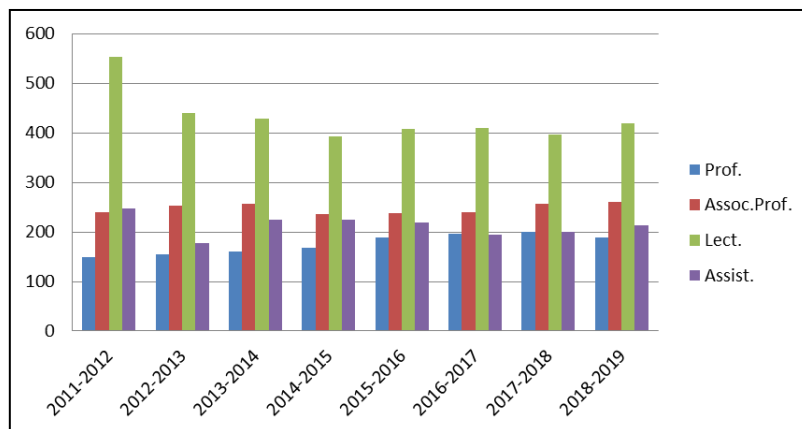

Figure 1. Distribution of teaching positions at the university level

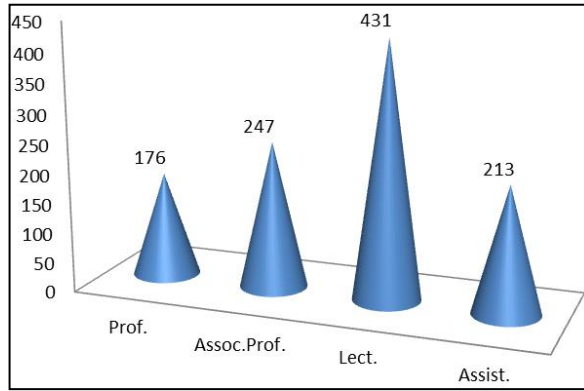

Figure 2. The average number of teaching positions in 2011-2019

For the analyzed period, it can be seen that at the university level, the number of professor positions represents an average percentage of 16.56% of the total number of positions (Figure 3).

Its evolution over the next five years shows an upward trend, the maximum being estimated in the academic year 2022-2023 (Figure 4).

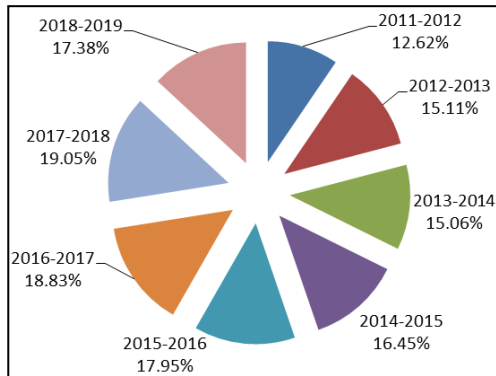

Figure 3. Percentage distribution of professor positions/academic year

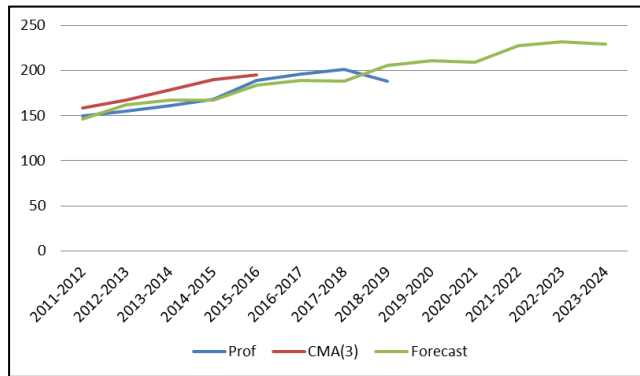

Figure 4. Forecast of number of professor positions

The number of associate professor positions represents an average percentage of 23.23% of the total number of positions (Figure 5). Although in the analyzed period the evolution of the number shows an upward trend, in the next five years there will be decreases, the minimum being estimated in the academic year 2022-2023 (Fig. 6).

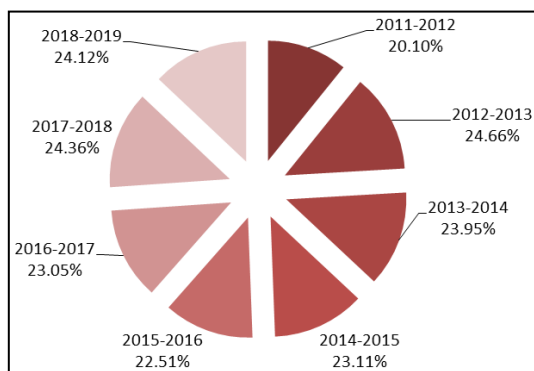

Figure 5. Percentage distribution of associate professor positions/academic year

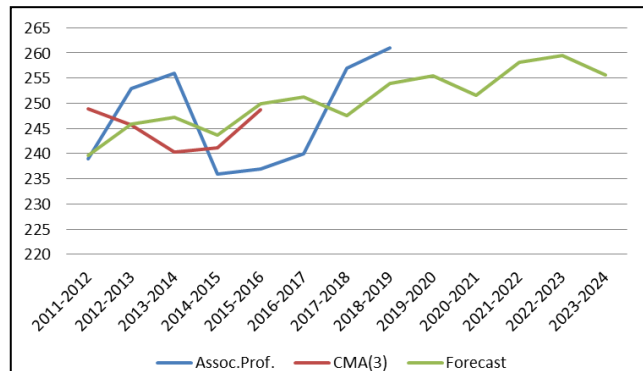

Figure 6. Forecast of number of associate professor positions

Although the number of lecturer positions represents an average percentage of 40,30% of the total number of posts, at the university level, this, for the analyzed and forecast period shows an downward trend, the minimum being estimated in the academic year 2023-2024 (Figure 7, Figure 8).

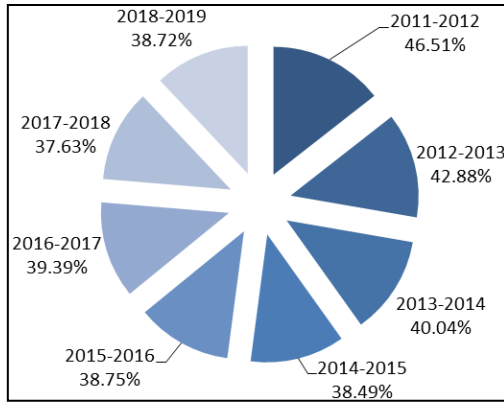

Figure 7. Percentage distribution of lecturer positions/academic year

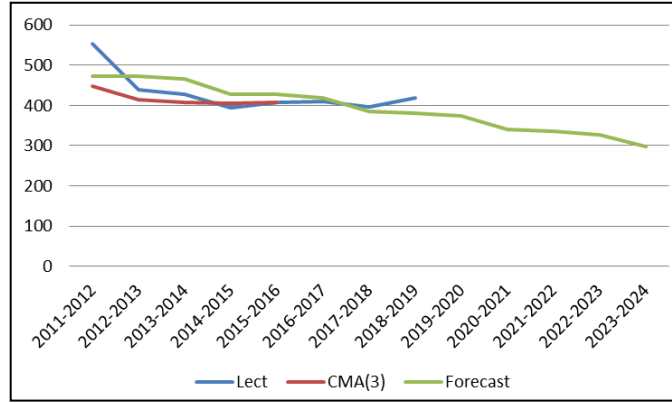

Figure 8. Forecast of number of lecturer positions

The average percentage of 19,91% of the total number of posts is represented by the number of assistant professor, whose evolution indicates both increases and decreases, the maximum being recorded in the academic year 2011-2012, and the minimum being estimated in the academic year 2021-2022 (Figure 8, Figure 9) .

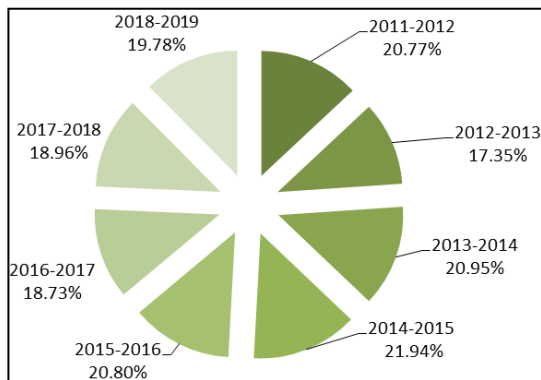

Figure 9. Percentage distribution of assistant positions/academic year

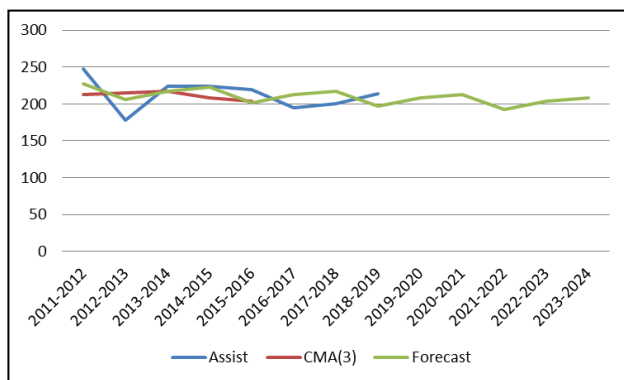

Figure 10. Forecast of number of assistant positions

Conclusion

1. The analysis shows that at the university level of the total number positions, the professor positions represent the minimum percentage while the lecturer positions represent the maximum percentage.
2. Small fluctuations in the number of professor positions can be justified through promotions (increases) and retirements (decreases).
3. The downward trend recorded by the evolution of the number of assistant positions can be interpreted on the one hand by means of promotions, but on the other hand, due to the lack of interest of young researchers in the system of employment.

Recommendations

Adoption of university management strategies for attracting young researchers, new specialists in the system.

References

- Mereuta, C., Mereuta, E., *Pachete integrate de aplicatii*, Editura Academica, Galati 2006, ISBN 973-8316-95-2, 109 pag.
- Veresiu, S., Mereuta, E., Rus, M., Ganea, D., Amortila, V., *Forecast of a quality indicator in academic activity using statistical methods*, IManEE International Conference 2017

Author Information

Madalina Rus

“Dunarea de Jos” University of Galati
Str. Domneasca Nr.47, Galati, Romania
Contact E-mail: *mrus@ugal.ro*

Elena Mereuta

“Dunarea de Jos” University of Galati
Str. Domneasca Nr.47, Galati, Romania

Silvia Veresiu

“Dunarea de Jos” University of Galati
Str. Domneasca Nr.47, Galati, Romania

Daniel Ganea

“Dunarea de Jos” University of Galati
Str. Domneasca Nr.47, Galati, Romania

Valentin Amortila

“Dunarea de Jos” University of Galati
Str. Domneasca Nr.47, Galati, Romania

FLOW Theory in the Preparation of Vocational Subjects Teachers

Eubica VASKOVA

Slovak University of Technology Bratislava

Dagmar RUSKOVA

Slovak University of Technology Bratislava

Abstract: The contribution deals with the FLOW theory of Czikszentmihaly. This theory is already well known in the professional psychological public. The FLOW theory is one of the main ways of achieving the so-called optimal highly focused mental state or optimal experience. According to its author, it depends on the ability of having control, at any moment, over what is happening in individual consciousness. It is one of the main determinants of what is simply referred to the term "happy and fulfilled life." The optimal experience is not the gift of being, it is the result of a purposeful, subjective effort of an individual. Life in the family may be the first impulse for identifying the path of the FLOW. The second, equally meaningful impulse should be the school or teachers and their educational activities. In order to successfully influence pupils in this area, the teachers need to focus themselves to FLOW issues. The authors of this article see a positive transfer of FLOW theory especially in realistically defined training and educational goals. The goals of the lesson have to be set to develop and respond to the quality of pupils' thinking logic. At the same time, there must be a significant motivational impulse to the action. And especially „the absorption" of the individual by subjective activity is a meaningful outcome of FLOW within the teaching process. Teaching and learning is a complicated and complex process. The versatility of this process results in the one hand, a wide range of scientific disciplines dealing with these notions (e.g. psychology, pedagogy, philosophy, biology, medicine, sociology, cybernetics, and the like) in the other hand a wide range of definitions, attempting to identify phenomena accompanying this multi-aspect and multi-factor process.

Keywords: Flow theory, Motivation, Educational goals

Introduction

The effort to fulfil own potential, to work on valuable life goals, to be deeply immersed in the thing that one believes in, to be committed to them, and to try to become true - these are the basic ways of the student's personality formation. How does the power of these factors change, what is the highest in their hierarchy? What is the place of the teacher in this process? The above mentioned factors are not products of genetic gear or life at all, they change their quality, while its metamorphoses are the result of considerable effort. Motivation, commitment, effort and perseverance represent not only the subjective power of the student, they are important drivers for the success and quality of students work determined primarily by the teacher's personality or the quality of their interaction. Professional literature considers the setting of external and internal personal goals to be one of the most important and most effective means of achieving optimum well-being in different situational contexts.

How should a teacher organize the lesson so that pupils have the chance to experience the most positive experience in school work? Are there general valid models of teacher's activity whose outcome is the FLOW status of his pupils? To put it simply, what does a teacher have to do to give pupils the greatest pleasure in their own work during lessons?

Results and Discussion

The phenomenology of enjoyment, according to its author, has eight main components. Thus, in reflecting the characteristics of the FLOW components into the reality of the educational process, we can define the following elements:

- 1 A prerequisite for positive survival is the fact that pupils are confronted with tasks or assignments that they have a chance to complete.
- 2 Pupils must be peacefully and meaningfully guided by teacher to adequate concentration
- 3 The task or assignment must be formulated in such a way that transparent cognitive or psychomotor goals are given to pupils
- 4 The teacher must in a two-way interaction, communicate with the pupils so that, at the time of solving the task or assignment, pupils are always provided with immediate feedback.
- 5 Formulation of tasks and assignments must be of interest to pupils so that in the process of their solution pupils have get into a state of non-violent but deep engagement.
- 6 Pupils must have a feeling of control over their actions or their work during lessons.
- 7 The interaction between the teacher and his pupils should be so absorbed that pupils gradually “forget each other”, after the interaction communication, the pupils “return” to their own ego with the feeling of its strengthening or highlighting.
- 8 The last characteristic of FLOW during lessons is the loss of the concept of time, which is only possible during meaningfully guided and quality bidirectional interaction.

In the didactic literature we can compare the effect of FLOW theory with the substitution effect, the main characteristic of which is the achievement of the pupil's success on the basis of previously experienced success - success produces success. The substitution effect is in the literature sometimes also mentioned as Matthew's effect. Its basic motif can be briefly summarized in the statement: "who has, will be added to him". To put it simply, the achievement of success is the driving force for such pupil's activities, which are once again a prerequisite for further success. The result of the combination of the above-mentioned FLOW components is that pupils experience a sense of deep enjoyment that is so enriching that pupils naturally desire its subsequent repetition. They are willing to spend a considerable amount of their own energy to repeat that feeling.

Belief in own Strength

A prerequisite for positive survival is the fact that pupils will be confronted with tasks or assignments that they have a chance to complete. Belief in pupils' own strength is reflected in teacher-pupil interaction into the didactic principle of adequacy. Adequacy means for the teacher to be demanding enough for the pupils, but demanding only to the extent that the task or assignment is achievable for the pupils. In the heterogeneity of pupils in the classroom, adequacy from the teacher requires not only a considerable dose of empathy, but also excellent pedagogical skills. In the dichotomy of feasibility versus inability to identify such boundary in which every pupil is found - excellent, average, but also lagging behind. It is clear from the above that the teacher has to prepare for the lesson a whole range of tasks, graded according to difficulty. Only then the teacher has the chance to address all pupils with assignments. Because if pupils receive tasks, assignments or questions that are resolved over their strengths or vice versa, the solution is trivial or quite simple, not requiring any energy, pupils gradually lose interest in such tasks. And to work without interest, without the spark of the inner motive, means for the pupils to issue unnecessary energy, the result of which is neutral or negative in terms of subjective enrichment. In the reality of the educational process, the applying of appropriateness is extremely difficult, requiring from the teacher to have a full range of pedagogical and didactic competences, enhanced by knowledge of psychology of pupils' personalities. Respecting the adequacy of the teacher towards pupils' means at every moment of the educational process to have a sense of balancing the challenges, it is finding a way of balance between students' abilities and their activities and activities during the lesson.

Adequate Level of Concentration

Pupils need to be non-violent, but meaningful guided by teacher to adequate concentration. If the appropriateness is right set, when "all the relevant skills of a person are needed to deal with a situation, then his attention it completely absorbed by that activity." There is no psychic energy left to process information other than the one that brings the action. The whole attention is focused on the relevant incentives” (p. 80). Appropriateness is thus one of the essential stimuli of full concentration. If the concentration can be

characterized by the spontaneity or absence of searching for meaningfulness, then another important element of an adequate degree of concentration is the motivation of the pupils. If a pupil doubts the meaningfulness of what is happening at the lesson, if his consciousness raises doubts such as "what for will I need this curriculum", "what is the meaning of what I am doing now", the teacher can never expect not only FLOW but also the adequate, meaningful or concentrated activity. The strength of motivation lies in the fact that the pupil is convinced of the necessity of his activities and of being active.

Transparency of Objectives

Each task or assignment within the educational process must be formulated so that the cognitive or psychomotor goals will be transparent for pupils. The importance of using such an active verb through which is clearly defined the activity of pupils, without the possibility of various subjective explanations is shown and underlined. The uniqueness of the verb ensures that the subject of the activity is precisely clear to the pupil. Manger's technique of setting out cognitive or psychomotor goals, in addition to the power of uniqueness of the verb, also emphasizes the need to clearly define pupil performance standards and pupil performance conditions.

These three elements complement each other in such a way that at each moment they allow the pupil to perceive the image of the quality and meaningfulness of his activity. In accordance with Seneca's statement "No wind is favourable to a boat that does not know to which port it is sailing", the transparency of the goal, together with the conditions and standards of performance, is the reason why full involvement in FLOW survival can be achieved.

Feedbacks

In a bidirectional interaction, the teacher must communicate with the pupils so that, at the time of solving the task or assignment, the pupils always have immediate feedback. Fulfilment of this condition of quality of teacher-pupil interaction is closely related to the previous condition. The form of feedback differs in the different activities and activities of the pupils during educational process, but the phenomenon of the criteria "good or bad" or „correct or incorrect" is a guideline for pupils without whom the deep immersion in activity cannot be experienced. The author of the FLOW theory says that the kind of feedback is not essential. The rationale for feedback lies in the message to the pupil whether he or she succeeds in achieving the goal. This message symbolizes success for pupils, which not only significantly enhances the structure of the ego, but also helps to create order in consciousness. Through this order, feedback is very actively involved in the quality of systematic long-term memory, whereby the FLOW theory strongly underlines the legitimacy of the feedback law in the learning process.

Concentrations

The formulation of tasks and assignments must be of interest to the pupils so that in the process of solving them the pupils get into a state of non-violent but deep engagement. Only a meaningful engagement gives students the chance to forget about all the other, not always pleasant and positive aspects of life. The more is the teacher able to get excited his pupils about the lesson, the greater is the assumption that pupils automatically exclude irrelevant information from their consciousness. What is more, they exclude and disperse distraction or anxiety. This process of nonviolent exclusion of irrelevant or "painful" parts of the pupils' consciousness helps to create a clean, unloaded mind and thereby visibly improves the quality of survival. Logically, positive experience is thus a way of creating order in consciousness. FLOW survival through the focus of concentration is a determinant that contributes significantly to the exclusion of chaos in consciousness. The process of minimizing chaos, the result of which is not only a pleasant mental state, but also the gradual establishment of order in the pupils' consciousness is called negentropy. The relational plane to entropy (the second law of thermodynamics) as a measure of disorder or chaos is obvious and intentional.

Controls

Students must have a sense of control over their actions or their work during the lesson. Although the feeling of control is often only hypothetical, it gives students the chance to make sure that excellence is achievable. Or to make sure that the possibilities of mistakes or failures are minimized by their own efforts, that the activity of the

pupils moves the possibility of errors as close as possible to zero. The author of the theory of FLOW Csikszentmihályi as a psychologist emphasizes that in this process is important to realize that people are not happy to feel that they have control, but a sense of control in difficult situations. The message for the educational process can be translated into a reference for teachers in order to concentrate much more on the process of education and training than on the results. If pupils are properly guided by their teachers, if the teacher interacts significantly with the process of the teaching, he gives pupils the chance to grasp their freedom to decide on the content of consciousness. This act of freedom is a lifelong, meaningful outfit of the pupils, willing to cope with the ambiguities of life.

Absorption, the loss of self awareness

The interaction between the teacher and his pupils should be so absorbed that pupils gradually “forget about each other”, after the interaction communication, the pupils “return” to their own ego with the feeling of its strengthening or emphasizing. A necessary condition for FLOW students from the side of teacher is to create a stimulating, positive interaction environment. From the pedagogical interaction, students have to feel joy, atmosphere at the lesson must be inspiring for the extraordinary possibilities of activities and enriching in terms of perfecting abilities or skills. Students must have a sense of belonging and a subconscious effort to do their best. The absence of ego in consciousness does not mean that the student gives up control of his mental energy. It is rather a holistic and analytical penetration that does not result in a loss of ego but a loss of consciousness of ego. The subsequent "emergence" of the ego is characterized by its reinforcement and improvement. The ego has features of complexity.

Measure of time

The last FLOW characteristic during lessons is the loss of concept of time. Again, the most important predictor of this FLOW condition is the quality of pedagogical interaction. The loss of the concept of time is only possible with a meaningfully guided and quality bidirectional interaction, where both the teacher and the pupils stop to perceive objectively the external quantifiable time indicators.

The author of FLOW describes two ways of relativisation of time – acceleration and deceleration. Acceleration shortens the objective time interval, the feeling of acceleration is more frequent, deceleration extends multiple times slowing the objective time. The deceleration can be detected by delving into the details of the activity with an emphasis on its excellence, focusing on absolute details. The operationalization of the activity relativizes the time measure, the student may have feeling that he has been doing the whole thing for an hour, but in fact it took only a few minutes. According to the author of FLOW, it is not clear whether the loss of time is only an accompanying phenomenon or it is something that contributes to the positive survival. Despite the confusion, we may conclude that abstracting from time is a pleasant change in today's hectic; the phenomenon of being freed from strict chronological aspects is a joyful enrichment not only for the pupils but also for the teachers.

Conclusion

The conclusion for motivation to apply FLOW in the teaching process is stimulating from both points of view - from "description of the state" and "content elements". The common denominator of these two points of view is the statement that a FLOW student does not do something for himself or for a teacher with the expectation of added value or positive assessment. The FLOW student is rewarded with the activity as such, the actual implementation and progress of the activity is rewarded for the student. This state we call autothotelic survival – auto means me and telos means goal. Thus, autothelic survival is such a survival, the main characteristic of which is the performance of an activity not for its consequences (even if they are positive) but for the activity itself. Didactically - to lead the lesson so that the process of the lesson itself is dominant, not knowledge or competence themselves. Qualitative and quantitative changes in s personality of student are the added value of FLOW theory.

References

Csikszentmihályi, M. *FLOW Psychológia optimálneho prežívania*. Bratislava. Citadella, 2015.381 s. ISBN 978-80-89628-711.

Turek, I., *Základy didaktiky vysokej školy*. Bratislava. STU, 2006. 248 s. ISBN 80-227-2573-0.

Belz, H., Siegrist, M. *Klíčové kompetence a jejich rozvíjení*. Východiska, metody, cvičení a hry. Praha. Portál, 2001. ISBN 80-7178-479-6.

Ruissel, I. *Inteligencia a myslenie*. Bratislava: Ikar, 2004. 432 s. ISBN 80-551-0766-1.

Author Information

Lubica Vaskova

Slovak University of Technology
Institute of Management
Supplementary Pedagogical Education
Vazovova ul 5.
812 43 Bratislava
Slovak Republic
Contact E-mail: lubica.vaskova@stuba.sk

Dagmar Ruskova

Slovak University of Technology
Institute of Management
Supplementary Pedagogical Education
Vazovova ul 5.
812 43 Bratislava
Slovak Republic

Organizational Change Management and Family Firms Socio Emotional Wealth: What Form of Impact?

Hind HOURMATALLAH
Cadi-Ayad University

Mohammed KHALIS
Cadi-Ayad University

Abstract: The speed and the complexity of political, regulatory, and technological changes, confronting most companies has made radical organizational change and adaptation, a central research issue. Although the raise and the integration of artificial intelligence is generally considered as an important lever that have increased the organizational change recurrence, So The purpose of this study is to identify how the family firme socio emotional wealth impact the change process implementation within organizations, and that's will take place by primary and secondary data analysis, illustrated by a case study.

Keywords: Organizational change, Family Business, Socio emotional wealth

Introduction

Considered for a long time as an obsolete and trivialized organizational form, the family business blames this for several reasons such as the quasi-dogmatization of A. Smith Work that urge the closure of capital, Also Chandler's work (1990) that explain the relative economic backwardness of Britain in the 19th century to the dominance of family firms and their reluctance to open up capital, the spectacular rise of managerial capitalism in most of the country. According to (Allouche, 2000), And that is quite plausible and legitimate. And currently, Today Business leaders are facing the complex task of leading their organizations and even their countries into the future, a trend is under way that is going to change the design of organizations, which make organizational change management a central issue for modern companies, on the other hand on academia, There's a consensus in literature about the fact that managing change is one of the hardest tasks, for instance based on a five year study conducted by the world-renowned McKinsey consulting firm (Isern, & Pung, 2007), out of the 1536 companies that underwent organizational change, only 38% of the company managers claimed that the process succeeded.

Moreover, what makes the situation more tight for managers is the seek of the organizational legitimacy which means that in today's competitive environment, organizations are forced to change according to the pressures of the outside forces, so as to survive, Referring to Beer (1997), Theoretically speaking when it comes to organizational change we can apprehend organizational change under two perspectives,

The first one is the passive point of view which consider firms transformation as a reaction, or adaptation to external environment changes, that's can be reflected as a response to a current crisis situation, or unexpected scenario, The second perspective is a proactive one, according to this approach organizational change appear like an event something that can be planned in advance, and it's a reflection of manager insight Van de Ven and Poole (1995).

Furthermore, family businesses are highly considered by the organizational since they fundamentally prepare the succession, and they are built-in a moving environment, when it come to family it's predominant at the world level is undeniable, two-thirds of companies in the economic sphere of Western countries have the family characteristic,

- This is an Open Access article distributed under the terms of the Creative Commons Attribution-Noncommercial 4.0 Unported License, permitting all non-commercial use, distribution, and reproduction in any medium, provided the original work is properly cited.

- Selection and peer-review under responsibility of the Organizing Committee of the Conference

However, it is necessary to mention that the field of "family business", is a domain which is characterized by a strong amphibology that is manifested in the fact that there is a lack of meaning unification the used theories. Worse, sometimes we find theoretical models and works that are based on diametrically opposed axioms facing this ambiguous reality we decide to answer the following question:

Research Question

Paradoxically with the reality the literature that focus on studying organizational change, concentrate most of the time on limited type of questions like : What are the antecedents or the consequences of establishing an organizational change? What are its forms and administrative practices? Or how does organizational change emerge develop, grow or terminate over time?

Meanwhile, lot of researches focused on two major subjects, the first one is the structural inertia that manifest like an obstacle in front of change implementation, and the scholars on that field are questioning, How strong are inertial forces on organizational structure? Or how can we eradicate them? The second type of questions is related to employee and their resistance towards change and how they can be involved on the change process? Or how managers can reduce their resistance level?

So in this research paper we aim to apprehend the phenomenon, under a new and an original perspective which study the relation between the family firms socio emotional wealth and organizational change implementation.

- How family business socio-emotional wealth impacts the process of organizational change implementation?

This problem is articulated around a certain number of questions which we summarize as follows:

- What is meant by organizational change? And what are its forms and dimensions within the family business?
- What are the factors responsible for the success and implementation of organizational change in Moroccan family businesses?
- What are the factors that hinder the implementation of organizational change in Moroccan family businesses?

Literature Review

Organizational change

Actually, the topic of organizational change is one of the major topic in management, because it is conceived as a solution allowing the organizations to react in front of all the crucial problems of adaptation to the environment on which it feeds and on which it depends. For some researchers (Beaudoin, 1990: 43), The change is all at once becoming, adjusting, adapt and transform, and for other writers like (Collerette et al 1997, 20), the change is "the transition from a state to another, which is observed in the environment and which has a relatively sustainable character. Profoundly speaking, Change is generally a reaction to some significant threat or opportunity appearing outside the organization. According to Pettigrew (Daft,1983) Changes within an organization can manifest in two forms, As a response to business and economic and social events or a proposition of a new managerial perception, choice and actions.

For better understanding of the change concept, (Lewin 1995), suggest a description of the change implementation process, which called «The Three-step Model of Change» :

The first step is «Unfreezing» : The present level reflect the confrontation or the process of re-education, which might be achieved through team building.

The second step «Moving» : To the new level which requires developing new behaviours, values and attitudes. The third step « Refreezing» : the new level seeks to stabilize the organization at a new state of equilibrium to ensure that the new ways are safe from regression.

But, until now nobody can deny the huge debates around the change management approaches, that have been fuelled by the contradiction between « deterministic» (Armenakis and Bedeian 1999, Pettigrew et al,2001, and Beer and Nohria 2000), and «voluntaristic», (Weick and Quinn, 1999,Sturdy and Grey, 2003) conceptions. The deterministic point of view of organizational change emphasizes the character inflexible of the organization, and apprehends the firms structure, system, and culture as factors of rigidity and inertia that tend to preserve the organization initial forms, Likewise, deterministic scholars (Aldrich, 1979,Hannan et Freeman, 1984), emphasizes the permanence factors of the organization and sees the pressures of the external environment factors as the main trigger of organizational transformations. In contrary, the intentional conception of organizational change, enhance the idea that change is imperative (change is good, stability is bad) and that change should be managed and controlled (Weick and Quinn, 1999), Moreover intentionalist explain that organization, in its systemic and human population, develops many resistances and poses that constraints to change.

In short, Change becomes a preoccupation inherent to the companies social activity, that generates the necessity toward a better understanding of its mechanisms, process and procedures, certain conceptual advances allow us today to conceive the firm performance and durability as resultants of it ability to implement change.

There are many reasons that change occurs in organisations, The Burke-Litwin model[1] shows the various drivers of change and ranks them in terms of importance.The model is expressed diagrammatically, with the most important factors featuring at the top

Figure 1. Litwen model that explain the multiple source of change

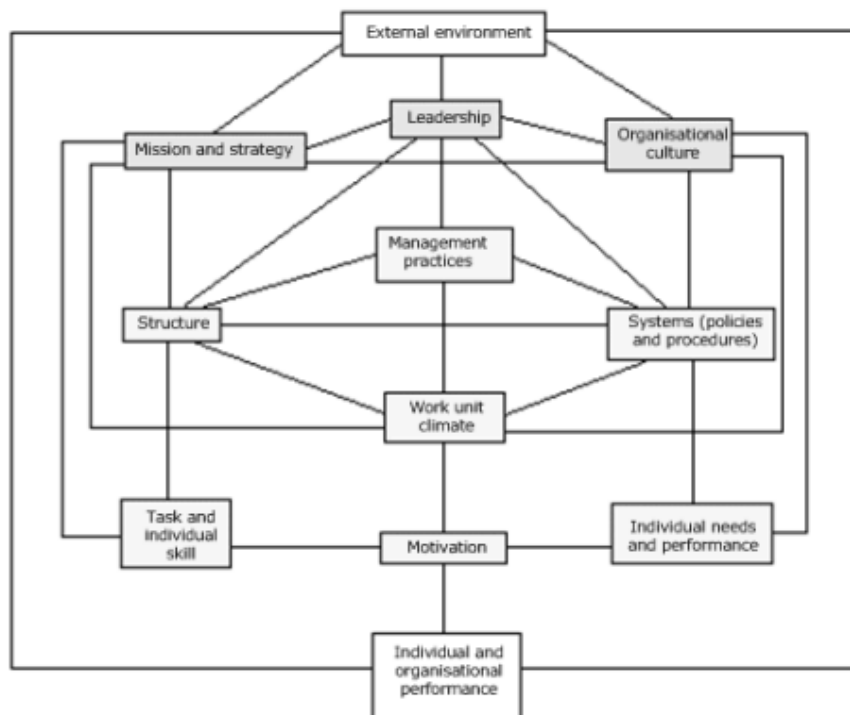

External Environment This includes such factors as markets, legislation, competition and the economy. All of these will have consequences for organizations, and, as a change manager, it is vital that you continually scan the environment for issues that will affect you and your team. For example, in the world of accountancy, International Accounting Standards and International Financial Reporting Standards will have a significant impact on the way companies manage their accounts and report their results. In the public sector, legislative changes across health, local government

Mission and Strategy

Very often, the strategy will be developed in light of environmental change, which imply that this element is extremely related and conditioned by the first one.

Organisation Culture Organization culture can be described as “the way we do things around here”. It considers the beliefs, behaviours, values and conventions that prevail in an organisation. Culture change does not happen overnight. It evolves over time as a result of many other changes in the organization.

Family business

The definition of what is a family business presents a huge controversy; the literature dedicated to this subject is unable to propose a definition that fit researcher’s expectations. On the other hand, we have a multiple and diversity of incomplete definitions, which anchor a structural ambivalence in this area and generates a high level of skepticism in relation to the value of the knowledge produced.

Several definitions emerge from the literature. For instance, mono-criteria definitions, which focus singularly on the criterion of ownership or that of control or that of the Family / Enterprise interaction.(BB Barnes, S.A. Hershon, 1976) focus on the notion of control, they consider that a firm is qualified as family one, only if the control of ownership is held by one or more members of the same family. The semantic amendment of this definition is done by (Lansberg et al., 1988), when he integrated the notion of "legal control".

On the other hand (W.J. Dyer, 1986), emphasis on the separation of ownership and management. He argued that a business is worthy of having family quality if ownership or controlled and influenced by a family. After (W.C Handler 1998) will present a virtually identical definition, the only point of difference is relative to the extended nature of the family.

Moreover, (Beckhard, R. and W.G. Dyer, 1983) have the exclusive right to approach for the first time interaction (family / business) as a defining criterion. They stipulate that the presence of the family on the board of directors constitutes the link that links these two worlds (family / company) and that give the family essence to the company.

The multi-criteria definitions are proposed to overcome the limitations of the previous one, and focus on ownership, control and family / business interaction and intention of continuity. MH Stern, (1986), concurrently proposes ownership, and control as two factors that determine the family or non-family nature of a business, so a business is considered family-owned when it is managed (controlled), and owned by one or more members of a family or several families, and (Rosenblatt, 1985) will support this definition by proposing the concept of involving family members in leadership through the exercise of effective roles in management.

In addition, (CM Daily, Mr. Dollinger 1992), reports the relevance of blood relationship between family members, it must be people (two minimum) with the same name, they must be involved in the board of directors of the company.

On the other hand, (Chanson, 1971) will try to quantify the problem by proposing scales of measurement for the criteria. For him, a company is defined as a family if its board of directors is chaired by a family member, and control is exercised successively by at least two generations, with a minimum of 5% of voting rights

Theoretical Background

Sense-making approach

Developed by the famous American psychologist (karl Weick, 1995), it consists in analysing the process according to which individuals or organizations create an understanding of the situations, which are often ambivalent, uncertain, and in perpetual change. Also Wieck(1998), emphasize the substantial role of this approach in the purification, of individual or organizational behaviours in time of change, which certainly leads to sense of harmonization, and engender more adequate reactions with the context.

Following this approach, sense construction mechanism in transformation time, will be triggered fundamentally by developing answers to questions like "what's going on?" "what should I do ? ", and in a more methodical way Klein (2009) propose three big sequential steps needed for sense edification in the changing period, (the clues detection, Situation framing, context appreciation).

Clues detection: Each individual within the organization that is involved in change process start by detecting the clues and indicators that seem important to him, and he will based his framing on those indicators. this selection is subjective in nature, because it depends on level of visibility of the signs in the environment as well as the "tank of the meaning already built» by these individuals, which actually is conditioned by the story of change implementation on the firm.

The Framing: as we said earlier this phase is intimately related to the first one, because the reading frame determine by the nature of the indicators that will be identified and decrypted by priority, also the situation framing is conditioned indirectly by the ideology, culture and history of the organization.

Context appreciation: Generally describes the place and time state, the challenge for organizations in this phase is to always stay in touch with the world around it, which can be difficult in some area, seen even unattainable in certain situation.

Moreover, The bottom line with the sense making approach, that change implementation is a more controllable process than we might think, by orienting the attitude of the worker and improves their cognitive and adaptive capacities, by a good leadership strategies which promote creativity and encourage innovation.

So with this approach we can understand that change implementation is a controllable process and the employee play a major role, because it's whom who's can facilitate or resist to the change implementation, and by good strategy of innovative leadership we can shape their behaviour and oriented to the right path, and that can be possible if the leaders plays in the sense mad by the employee on the change period and their emotional reaction.

Also, this approach emphasize the learning aspect in the transformation period it states that concurrently, when taking actions to implement new system we are building meaning which will be part of a long term learning process, it could be a «single loop learning», «double loop learning», or «Learning By doing». and the process is deceive in the change implementation success because, There is a delicate trade off between dangerous action which produces understanding and safe inaction which produces confusion»

Stake-holders theory

Recently, with the development of the new economy and the neo-institutional approach, scholars have become increasingly interested in the concept of stakeholder, because they all aware of it importance and how stake holders can be a promoter or a destroyer of firms competitiveness.

William Freeman, 1963 , by a simple word game during a communication at the Stanford Research Institute, he took the English term "shareholders" he replaced the syllable "share" by "Stake", which gave birth to the new term "stakeholders", which refers to a group of individuals who have interests to receive from organization. Nevertheless, there is a truth, assuming that any truth good to say, the consensus is far from being established about a definition of the concept «stakeholders», according to (Freeman, 1984) the stakeholders are all institutions or individuals that can impact or be impacted by the achievement of the company's objectives " and for (Mercier, 1999), the stakeholders are all individuals or groups for whom the development and durability of the firm is a crucial issues.

Beyond the definition issues (Carroll, 1995) proposes a classification of Stakeholders in which he distinguishes two broad categories:

Primary stakeholders: who are usually in contact with the company through contractual links such as (employees, bank, supplier, ...).

Secondary stakeholders: the opposite of the first category are agents linked with the company through non-formal and non-contractual links (lobby groups).

Moreover, according to (Donaldson and Preston, 1995: 74) this theory has three empirical dimensions: descriptive, instrumental, normative.

Descriptive: this is the most visible part of this theory, it reflects the way with which the organization takes into account the interests of the different stakeholders, it describes the management system and the nature of the company behaviour toward the stake holders:

Instrumental: it is the most pragmatic dimension between these three, it represents how the company seeks to exploit the consideration of the interests of its various Stakeholders to achieve its objectives of an economic nature.

Normative: this variable is relative to everything that is ethical it argues that firms are currently under the obligation to take equitably the needs of all stakeholders because the durability of the company depends mainly on its behavior towards of all stakeholders

Research Methodology

The results presented in this paper are the fruits of a large empirical study conducted, based on the available data provided by the consulting companies, The methodology of this research as well as the framework of the study will be presented here in a synthetic way down below.

First things first, we choose a qualitative research, and an interpretive approach that seeks to describe, comprehend, and explain people behaviours in terms of the meaning it holds for them. Compatibly with positivism, Interpretativiste research retains the assumption that the goal of research is to describe and explain reality without a value bias. contrary to the positivist approach, the interpretive viewpoint rejects the possibility of creating generic laws (Bain, 1989), As a result of that, this research main focuses is to understand individuals perceptions, opinions, beliefs, and the assigning of these views with an underpinning meaning. However, under the qualitative perspective particular attention is paid to the research assumptions, and the subjective perceptions of the respondents. Also this interpretive approach holds that based on people's individual and collective thinking and action, we create meaning which can be made intelligible (Minichiello, Aroni, Timewell, & Alexander, 1995).

The qualitative methodology adopted, stand on with the conceptions of the «case study method» developed by Yin [1989] which focused on demonstrating how relevance and interesting the case study it could be, As a research strategy . This approach is in line with the mainstream of our research, which requires taking completely and deeply into account, the organizational change context in which the actors are nested, Yin [1989: 23], Therefore (Cress, 1999) said that case study is a good approach if purpose of researcher is to investigate the process.

Since the focus of this research is exploratory in nature, and we seek by this study to provides a unique ability to capture empirical descriptions of phenomena such as integration. To this end we used a grounded theory methodologies, (Glaser and Strauss in 1967).

Grounded theory methods emerged from the work of the well known sociologists Barney G. Glaser and Anselm L. Strauss's (1965, 1967) after a successful teamwork during their studies related to the dying people in hospitals (see Glaser & Strauss, 1965, 1968; Strauss & Glaser, 1970). In the early 1960s in the United States, hospital staff seldom talked about or even acknowledged dying and death of seriously ill patients. As they constructed their analyses of dying, they create systematic methodological plan of action that social scientists could adopt for studying many other subjects. Glaser and Strauss's book *The Discovery of Grounded Theory* (1967) first introduced these strategies and advocated developing theories from research grounded in data rather than deducing testable hypotheses from existing theories.

Grounded theory focus on the progressive identification and integration of meaning categories extracted from data. It is a double process that aims to identify and integrate the categories (as method), and its product (as theory). meanwhile GT, as method provides us with schema on how to identify categories, how to make links between categories and how to establish relationships between them. Moreover, Grounded theory use a number of key strategies, including constant comparative analysis, theoretical sampling and theoretical coding, which Let us take a closer look at the major analytical constructs, or building blocks, of the grounded theory method. The grounded theory method has undergone a number of revisions. Most significantly, Glaser and Strauss themselves parted company and proposed different ways in which grounded theory thought to be practised.

Material and Methods

Using grounded theory by the case study method, Eisenhardt (1989), implies the utilization of multiple data collection methods, multiple investigators, flexible and opportunistic data analysis methods, and cross-case analysis, comparison to the literature. So in our research, The collection of data was carried out by an accumulation of information extracted from numerous sources of evidence, included publicly available documents, journals, reports. Observation, desk research and semi-structured interviews represent the bulk of field work.

We conducted more than one case studies to check the validity of the change management proposed model. Researchers get different kinds of observations from these case studies because each company have different strategies, scopes, and market. Meanwhile The processing and qualitative data analysis was done through a cyclical and iterative process which can be synthesized by repeating this three phases identified by Miles and Huberman [1991]:

Condensation of data: Operation that consist to organize data so as to make intelligible and voluminous facts from chaotic informations.

Presentation of data: Consists to draw conclusion from analysing already built informations. The elaboration / verification of the results: The results are elaborated with a more and more important degree of abstraction to lead to theoretical propositions. They are related to empirical data through inferences.

Our “analysis” involved the collection, cumulative coding cycles, and reduction of qualitative data. We looked for reflective themes and tried to “search for patterns in data and for ideas that help explain why those patterns are there in the first place” (Bernard, 2011). and all the data that we used is qualified as secondary data, published by Deloitte in (2016).

Results and Discussion

Secondary data-analysis (survey documentary analysis)

We will be delighted to present the results of how Change Management process can be impacted by the innovative leadership, The research will focus on verifying the compatibility between the theoretical ideas and the empirical facts, by identifying the most popular Change Management ideas. The survey that we will use are whom conducted by Deilolitte, in 2016 which was structured to identify the level of Change Management awareness among participants as well as the relationship between the application of the Change Management tools and the successful implementation of innovative processes.

Here’s some examples of The surveys participants which represent a diverse selection of companies in different fields, this Change Management survey attracted the attention of a number of managers in charge of planning and implementing project activities, because they are the one who are involve and able to communicate authentic knowledge, Down below some examples of the secondary data available.

Figure 1. Breakdown of survey participants by their role inside the organizations

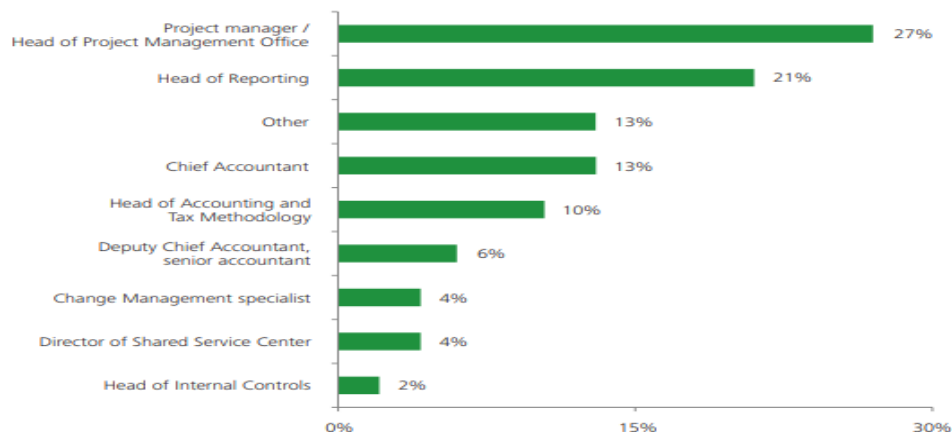

Source : ¹Deloitte Survey (2016)

Refereeing to the literature, change is define as a transition from one state to another. Also Change is perceived like continuous and embraces all areas of life and activity of a single person, organization or society at large. Down below there's a benchmark between literature and reality regarding these definitions.

Figure 3. Agreement about the definition of change management

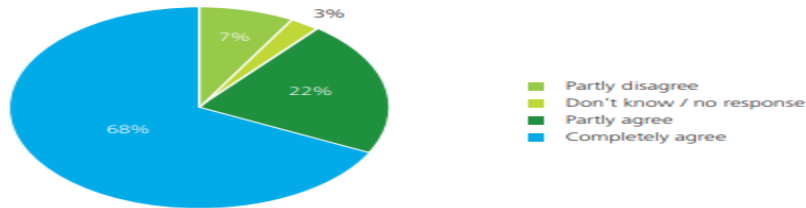

Source : Deloitte Survey (2016).

100% of survey participants agree that the success of any business transformation is determined by effective procedural engagement, and Change implementation is a continuous process that can and should be managed by phases, so the coming question are related to this fact.

Figure 4. The Change Management process, on the participant opinions

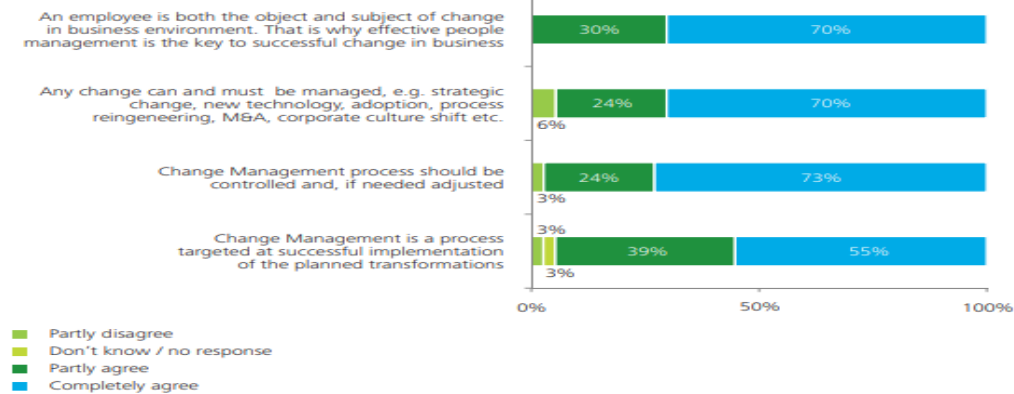

Source : Deloitte Survey (2016).

And about the innovative leadership, Deloitte conducted another survey about 15 minute quantitative questionnaire conducted on line Approximately 300 interviews per market, and compatibly with the theoretical work,participants agreed that innovation is essential for business growth and 87% believe the success of a business should be measured by more than just financial performance, but also the ability of managing change, moreover they confirmed the fact that Creativity is the key factor for innovation, followed by academic ability, technical skills and the ability to challenge. Also it certainly help in managing the external changes.

Figure 5.:Innovation helps in company transformation in order to face External Challenges



¹ Deloitte is one of the "Big Four" accounting organizations and the largest professional services network in the world by revenue and number of professionals. Deloitte provides audit, tax, consulting, enterprise risk and financial advisory services with more than 263,900 professionals globally. In FY 2017, the network earned a record \$38.8 billion USD in aggregate revenues. As of 2016, Deloitte is the 6th-largest privately owned organization in the United States.

Source : Deloitte Survey (2015).

Primary data-analysis (case study SOREMAR FAMILY BUSINESS)

Since its creation in 1999, SOREMAR has successfully improved its position in the global automotive industry, ranking among the best of the Moroccan biggest maritime manufacturer. We choose this case for Not only its economic performances but also for the fact that during the past years it encountered a lot of organizational changes because of the different type of Challenges that it faced like the global financial crisis left marks on the maritime industry. Further to that, trends such as increasing competition and stronger environmental regulations already have and further will challenge that market. Moreover Ford is well known by its investment in the innovation Paradigm.

Analysis process (TROPES Software) :

As we said earlier we will gather data by in depth interviewee, later on we will proceed by transcription, “analysis” involved the collection, cumulative coding cycles, and reduction of data, and all this will be done thanks to TROPES.

Tropes is created by (Agnès Landré and Pierre Molette 1998), they take as fundamentals the work of (Rodolphe Ghiglione, 1988) this software offers the possibility to perform a semantic text analysis. (Wheel & Manual, 2013), Furthermore it allows for a two-dimensional content analysis, that could be divided in two phases, in the first one, researcher subjectivity is eliminated thanks to the realization of strict statistical treatment of collected data, the second one is related to the researcher's interpretation work, it gives the possibility to the latter to carry out an analysis of the textual content based on conceptual scenarios constructed by the researcher himself. By the way for (Garcias F. et al., 2010).

Down below a list of manager’s that were interviewed

Name	Position within company	The source of the interview
Noureddin gnaou	President and chief executive officer of the Ford Motor Company.	Stanford Graduate School of Business conference
Dounia gnaou	Ford Motor Group Vice President of Global Product Development.	Bloomberg channel
Karim gnaou	Director of Research and Advanced Engineering, Ford Motor Company.	Bloomberg channel

Yet, firstly we started with a statistical presentation of different categories of terms used by the actors some examples interviewed

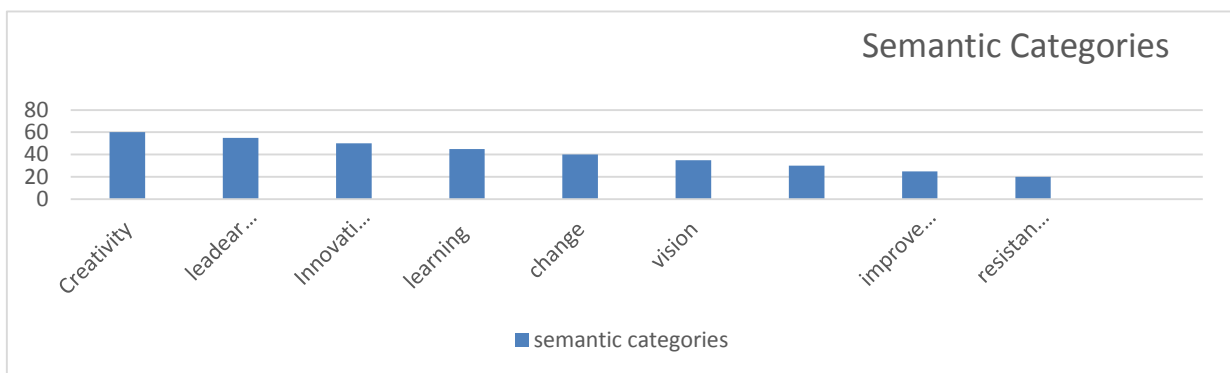

We find out that terms like «creativity-innovation-change-leadership..» have a pretty considerable presence in the speeches of FORD MOTORS managers, and that reflects the fact that (innovative leadership and change management are quite related topics, Because thanks to a well planned strategy of innovation FORDMOTORS was able to face all the changes stirred by the environmental and the external forces, moreover investing in developing a good leadership practices certainly will have a huge impact on the change implementation within FORD MOTORS COMPANY.

The second type of analysis will focus on the relationship that remains between the different categories of terms through the use of what is called "the area graph, the latter is composed of two axes (horizontal and vertical), the studied concepts are exposed in the form of balloons on the left and right, this results from the action (taker/ receiver) relationship, as well as the size of each balloon depends on its importance in the story, and the proximity between the sphere and the center area reflects the level of relationship between the two concepts. . The area graphs are provided by the Tropes software based on a statistical study of the repetitiveness of the terms positioning before and after the verb. Hers' an example down below

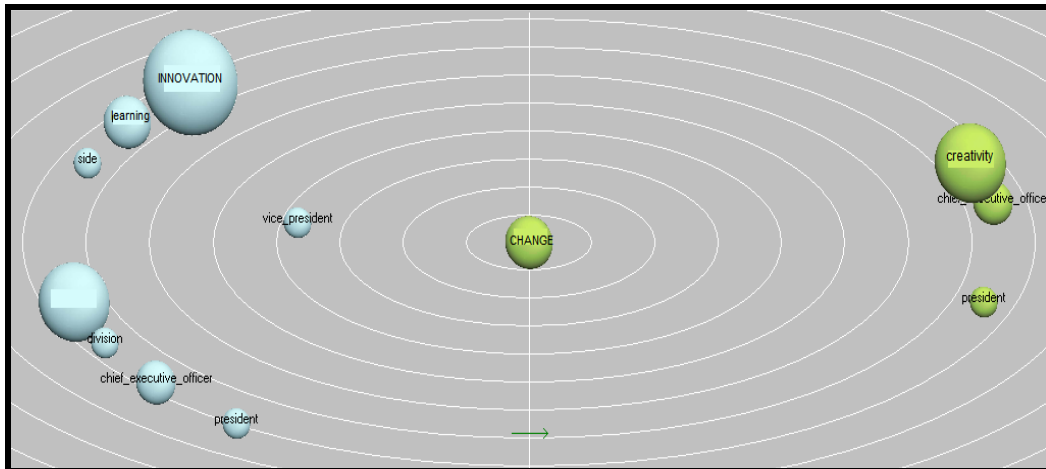

at first sight, we find that the sphere "INNOVATION" is the closest in the middle and it is present in the biggest ball, this justifies that innovation is a key factor in change implementation and creativity is the base of all innovation work,

Conclusion

As conclusion we can say that the family business socio emotional has a multi-dimensional impact on organizational change implementation for instance if the family is well-constructed and the social value are correct and visible it would have positive impact and vice versa.

References

References and citations should be prepared in the latest APA (<http://owl.english.purdue.edu/owl/resource/560/02/>) format. References have to be cited in article text. See the references examples below.

- Abrahamson, Edwen D. (2004), Change without Pain: How managers can overcome initiative overload, organizational chaos, and employee burnout, Harvard Business School Press, Boston, 218 p.12
- Appelbaum, Steven H, Delage Claude, Labid Nadia et George Gault, (1997), The Survivor Syndrome: Aftermath of Downsizing, Career Development International, Vol. 2, Iss. 6, p. 278
- Ashkanasy, Neal M., Wilfred J Zerbe et ChaffiÈne E. J. Hartel, (2002), Managing Emotions In the Workplace, M.E. Sharpe, Armonk, New York, London, England. p. 357.
- Abrahamson, Edwen D, (2004), Change without Pain: How managers can overcome initiative overload, organizational chaos, and employee burnout. Harvard Business School Press, Boston, 218 p.12
- Bartoli, Annie et (1986), Piloter l'entreprise en mutation Une approche stratègique du changement.,Les éditions d'organisation; 259 p.
- Bateson, George Emery, Jean-Luc, (2000), Le rôle des émotions. Sciences humaines, Hors Série no 28, mars avril mai, p. 14-16. 159
- Beaudoin, Pierre, (1990), La Gestion Du changement: Une approche Stratègique pour l'entreprise en mutation. Stratègies d'entreprise, 220 p.
- Boucher, Marie-Claire, (1974), L'horaire variable de travail: Progrès ou anachronisme». In Aménagement des temps de travail: L'horaire variable et la semaine comprimée. (dir. Publ.), p.45-82.
- Brun, Jean-Pierre, al.,(2003), Évaluation de la santé mentale au travail: Une analyse des pratiques de gestion des ressources humaines, IRSST, p. 89.

- Boneu, François, Françoise Fettu et Luc Marmonier, (1992), *Piloter le changement managérial*. Éditions Liaisons, 175 p.
- Burnes, Bernard. (2004), Kurt Lewin And Complexity Theories: Back to the future, *Journal of Change Management*, vol. 4, no 4, 309-325.
- Collerette, Pierre et Gilles Delisle, (1982), *Le changement planifié: Une approche pour intervenir dans les systèmes organisationnels*, Les éditions agence d'ARC Inc., Montréal. 213 p.
- Collerette, Pierre, Gilles Delisle et Richard Perro, (1997), *Le changement organisationnel: Théorie et pratique*. Presse de l'Université du Québec. p. 173
- Collerette, Pierre, Robert Schneider et Paul Legris, (2001), *La gestion du changement organisationnel : Première partie Changer dans la turbulence*, ISOManagement Systems, octobre, p. 38-45.
- Collerette, al, (2003), *La gestion du changement organisationnel : Cinquième partie Communication et Changement*. ISO Management Systems, mai/juin, p. 48-57.
- Cooper, Cary. L. et Judi Marshall, (1976), Occupational source of stress: A review of the literature relating to coronary heart disease and mental III health, *Journal of Occupational Psychology*, vol. 49, p. 11-28.
- Cox, T., A. I. Griffiths, C. A. Barlow, (2000), *Organizational interventions for work stress: A risk management approach*, Sudbury, HSE books. Dejours, Christophe, (1993), *Travail: Usure mentale: Essai de psychopathologie du travail*. Paris, Bayard, p. 263.
- Demers, Christiane. (1999), *De la gestion du changement à la capacité de changer: L'évolution de la recherche sur le changement organisationnel de 1945 à aujourd'hui*. *Gestion*, vol. 24, no 3, septembre, p. 131-139.
- Hannan, M. T., & Freeman, J. (1984), Structural inertia and organizational change., *American sociological review*. 149-164.
- Fabi, Bruno, (1999), L'engagement organisationnel des personnes oeuvrant dans des organisations en transformation: Qu'avons nous appris, *Gestion*, vol. 24, no 3, p. 102-113.
- Guilhon, A. (1998), *Le changement organisationnel est un apprentissage*. *Revue française de gestion*, (120), 98-107.
- Moison, J. C. (2010), L'évaluation du changement organisationnel par l'approche de la recherche intervention. L'exemple des impacts de la T2A. *Revue française des affaires sociales*, (1). 213-226.
- Calfee, R. C., & Valencia, R. R. (1991). *APA guide to preparing manuscripts for journal publication*. Washington, DC: American Psychological Association.
- Duncan, G. J., & Brooks-Gunn, J. (Eds.). (1997). *Consequences of growing up poor*. New York, NY: Russell Sage Foundation.
- Harlow, H. F. (1983). Fundamentals for preparing psychology journal articles. *Journal of Comparative and Physiological Psychology*, 55, 893-896.
- Helfer, M. E., Kempe, R. S., & Krugman, R. D. (1997). *The battered child* (5th ed.). Chicago, IL: University of Chicago Press.
- Henry, W. A., III. (1990, April 9). Making the grade in today's schools. *Time*, 135, 28-31.
- Lastname, F. N. (Year). *Title of dissertation*. (Doctoral dissertation). Retrieved from Name of database. (Accession or Order Number)
- Lastname, F. N. (Year). *Title of dissertation*. (Unpublished doctoral dissertation). Name of Institution, Location.
- O'Neil, J. M., & Egan, J. (1992). Men's and women's gender role journeys: A metaphor for healing, transition, and transformation. In B. R. Wainrib (Ed.), *Gender issues across the life cycle* (pp. 107-123). New York, NY: Springer.
- Plath, S. (2000). *The unabridged journals*. K. V. Kukil (Ed.). New York, NY: Anchor.
- Schnase, J. L., & Cunnius, E. L. (Eds.). (1995). *Proceedings from CSCL '95: The First International Conference on Computer Support for Collaborative Learning*. Mahwah, NJ: Erlbaum.
- Schultz, S. (2005, December 28). Calls made to strengthen state energy policies. *The Country Today*, pp. 1A, 2A.
- Scruton, R. (1996). The eclipse of listening. *The New Criterion*, 15(30), 5-13.

Author Information

Mohamme KHALIS

Cadi Ayyad University
University, Marrakesh, Morocco
Contact E-mail: hourmat_hind@yahoo.fr

Hind Hourmatallah

Cadi Ayyad University
University, Marrakesh, Morocco

The Effects of the Flipped Classroom and Peer Instructional Models on Learning Calculus

Muhammed SYAM

United Arab Emirates University

Derar SERHAN

Arizona State University

Farouq ALMEQDADI

Emirates College for Advanced Education

Abstract: This study investigated the effects of the flipped classroom and peer instructional pedagogical models on students' achievements in Calculus for Business courses. One hundred eight students participated in the study and were divided into three groups. The Control group (35) was taught according to the traditional model; the first experimental group was taught according to the flipped classroom model (36); and the second experimental group was taught according to both the flipped classroom and the peer instruction models (37). Students in the experimental groups watched recorded lecture videos on Blackboard and solved an online pre-assignment before coming to class. A quasi-experimental design was implemented and two research instruments were designed and used; a pre- and post-tests. All the participants took a pre- test during the first week of the semester and completed a post-test after the treatment during the fourteenth week. The results of this study showed that students' achievements in the peer instructional classroom surpassed those of students in the other two sections.

Keywords: Flipped classroom, Peer instructional classroom, Calculus, Mathematics education

Introduction

Calculus is an entry topic for all students at the college of business and economics in the United Arab Emirates University (UAEU). The importance of Calculus in a wide range of disciplines promoted researchers to develop and use several teaching techniques and tools to improve the learning process including concept maps, graphing technologies, mathematics software and iPads (Al-Refai, Alshannag & Syam, 2014; Batista, Behar & Passerino, 2013; Ellison, 1993; Estela Carbonell & Saà Seoane, 2009; Hohenwarter, Hohenwarter, Kreis, & Lavicza, 2008; Kadry & El Shalkamy, 2012; Serhan & Syam, 2011).

Student engagement is one of the most important factors in effective learning. For this reason, researchers used different techniques to achieve this goal. The flipped classroom model is one of these techniques. It is a form of blended learning in which students learn content online by watching video lectures, usually at home, while work is done in class where instructors and students discuss and solve problems. The model offers a personalized student-instructor interaction as the roles of instructors shift more toward guidance than giving lectures.

Another model is the Peer Instruction Model which is an interactive student-centered learning technique developed by Harvard Physics Professor Eric Mazur (1997, 2012) in the early 1990s to enhance students' conceptual learning through small group discussions. In Mazur's technique, students answer conceptual questions independently, then they are asked to discuss their answers with their neighbors to convince them of their answer. This technique works best if students prepare before class and then test their application of knowledge in class. Peer instruction has proven to be an effective instrument for improving student learning in different scientific fields (Deslauriers, Schelew & Wieman, 2011; Gok, 2012; Lucas, 2009; Pilzer, 2001). Peer

- This is an Open Access article distributed under the terms of the Creative Commons Attribution-Noncommercial 4.0 Unported License, permitting all non-commercial use, distribution, and reproduction in any medium, provided the original work is properly cited.

- Selection and peer-review under responsibility of the Organizing Committee of the Conference

instruction emphasizes in-class interactions between instructor and students and students and peers. The peer instruction flipped learning model blends the concepts of flipped classroom and peer instruction in order to maximize the strengths of both models.

There are many varied models of flipped classrooms that were used by researchers including: entrance quizzes, in-class clicker questions, using mobile response devices, just-in-time teaching, problem-solving in groups, peer discussion and student presentations (Bates & Galloway, 2012; Demetry, 2010; Deslauriers, Schelew & Wieman, 2011; Frydenberg, 2012; Gannod, Burge & Helmick, 2008; Lage, Platt & Treglia, 2000; Moravec, Williams, Aguilar-Roca, & O'Dowd, 2010; Strayer, 2007; Strayer, 2012; Talbert, 2012; Toto & Nguyen, 2009). In addition, some research studies focused on the benefits of flipping college physics, engineering, mathematics and technology courses. They found out that the students who used the flipped classroom model were more engaged in learning class content outside of class, they felt more challenged and more eager to learn, they were also more involved and more open to cooperative learning. In addition, students indicated that the instructional videos helped them in learning the class content and pointed out that they liked the time they spent working on different activities in the classroom (Carlisle, 2010; Demetry, 2010; Frydenberg 2012; Strayer, 2007).

In a flipped introductory programming course, Carter (2012) used both peer instruction and JiTT. Before class, students viewed screenshots and then at the beginning of class, student comprehension was assessed using Clicker questions. When there was significant disagreement on the correct answer to a clicker question, mini lectures and peer instruction were used. The remaining class time was spent in active-learning group activities. The researcher found that students strongly favored the flipped approach over a traditional lecture style of instruction.

Given the growing interest in flipping pedagogy, in this paper, we discuss the effects of using the flipped classroom and peer instructional models on the learning process in a Calculus for Business and Economics course.

Purpose of the Study

The purpose of the study was to investigate the effects of using the flipped classroom and peer instructional approaches on students' achievements in a business calculus course.

The main research questions were the following:

- What is the effect of the flipped classroom as well as both the flipped classroom and peer instructional models on student achievement in a business calculus course?
- Is there a significant difference between student achievement in the flipped classroom vs the flipped and peer instructional classroom vs the traditional classroom?

Method

Participants

The students who participated in this study were enrolled in a Calculus for Business and Economics course at a major university in the United Arab Emirates. One hundred eight students participated in this study. The participants were enrolled in three sections: The traditional classroom (control group, 35 students), the flipped classroom (Experimental group 1, the flipped classroom group, 36 students) and the flipped classroom and peer instruction group (Experimental group 2, the peer group, 37 students). The students in this course used the textbook "*Calculus for Business, Economics, and the Social and Life Sciences*" (Hoffmann, Bradley, Sobecki & Price, 2013). The textbook emphasized the real-life applications in business of the different calculus concepts.

The assessments consisted of a pretest and a post test. The pre- and posttests were identical and contained twelve essay questions (see (Table 1) for test specifications).

Table 1. Questions' Specifications

Content/Cognitive	Knowing	Applying	Problem solving and reasoning
Limits	Q1	Q2	Q3
Continuity	Q4	Q5	Q6
Differentiation	Q7	Q8	Q9
Integration	Q10	Q11	Q12

The learning outcomes for the period of study are:

1. Compute the limits and the discontinuity of several elementary functions.
2. Compute derivatives of several elementary functions.
3. Evaluate different types of definite and indefinite integrals.
4. Apply mathematical models and tools to various business and economics problems.

Treatment

In this study the quasi experimental design of the form was used:

$$\begin{array}{r}
 O_1 - X_1 - O_2 \\
 O_1 - X_2 - O_2 \\
 O_1 - \quad - O_2
 \end{array}$$

All participants agreed to participate in this study. One of the researchers gave both experimental groups a training session on the flipped classroom instructional approach (Experimental group 1) and on the flipped classroom and peer instructional approach (Experimental group 2). He explained these instructional approaches and gave examples. Blackboard was used during this study for both experimental groups.

The instruction for both experimental groups consisted of the following:

- I. Before class, students in both experimental groups watched recorded lecture videos on Blackboard and solved an online pre-assignment. In the meantime, instructors analyzed the feedback from the online pre-assignment, prepared worksheets for the next class and designed a short PowerPoint presentation. In addition, and for experimental group 2, instructors prepared multiple choice questions.
- II. During the class, students in Experimental group 1 worked on solving worksheets (independently), they also worked on team mini-projects, asked questions and participated in class discussions. In addition to doing similar tasks, students in Experimental group 2 solved a sequence of multiple-choice questions. The instructors gave short presentations based on the online pre-assignment feedback, they facilitated and supported students' individual inquiries and collaborative work. For experimental group 2, after the short presentation, the instructor asked the multiple questions one by one based on students' responses.

Procedure

During the first week of the semester, the researchers explained to the instructors the purpose of the study. Data were collected from a pre-test that was conducted during the first week of the semester, as well as from a post-test. The same questions were used for the post-treatment test which was given during the fourteenth week of the semester. Both tests were administered by one of the researchers and taken by students without any interference from the researcher. In the fifteenth week a survey was given to students in the two experimental groups.

Analysis

The aim of this study was to investigate the effects of using the flipped classroom and the flipped and peer instructional models on students' achievement in a math class, in addition to investigating their attitudes towards

these models. To answer the research questions, a detailed statistical analysis was conducted. The data collected from the pretest and posttest were analyzed using SAS (Version 9.4: SAS Institute Inc.) to check for any statistical differences between the three groups, thus providing answers to the first research question regarding the effects of using these models on students' achievement. Responses to the survey items were categorized as follows: Students' interactivity and confidence, Students' effort, and Students' perceptions.

Results

The mixed models procedure was used in the analysis to test the effects of the experimental groups' type, time point, and experimental groups' type x time interaction on the scores. Post hoc tests were done on least-squares means using Tukey adjustment for multiple comparisons. Statistical analyses were performed using SAS (Version 9.4: SAS Institute Inc.). (Table 2) shows that there was no significant difference between the means of the pretest between all the groups, while there was a significant difference between the peer group and the other two groups (the control and the flipped classrooms).

Table 2. Mean differences of Pre and Post-tests between the groups

Score	Difference (Peer to Control)*			P-value*	Difference (Flip to Control)*			P-value*	Difference (Peer to Flip)*			P-value*
	Mean	95% CI			Mean	95% CI			Mean	95% CI		
		Lower	Upper			Lower	Upper			Lower	Upper	
Pretest	0.02	-0.96	1.01	1.000	-0.04	-1.04	0.95	1.000	0.07	-0.91	1.05	1.000
Posttest	10.58	8.91	12.24	<0.001	1.80	0.12	3.47	0.029	8.78	7.12	10.44	<0.001

*Tukey adjusted post hoc test

(Table 3) gives the mean differences between the pretest and the posttest for each group, there is a significant difference between the posttest and the pretest for each group.

Table 3. Mean differences within each group

Score	Pretest			Posttest			Difference (Time 2 to Time 1)*			P-value*
	Mean	95% CI		Mean	95% CI		Mean	95% CI		
		Lower	Upper		Lower	Upper		Lower	Upper	
Peer	2.59	2.12	3.06	16.92	16.12	17.71	14.32	13.05	15.60	<0.001
Flip	2.53	2.05	3.00	8.14	7.33	8.94	5.61	4.32	6.90	<0.001
Control	2.57	2.09	3.05	6.34	5.53	7.16	3.77	2.46	5.08	<0.001

Discussion

This study aimed at investigating the effects of the flipped classroom as well as the peer instructional models on students' achievements in Calculus for Business and Economics courses. The 108 participants took a pre- test during the first week of the semester and completed a post-test after the treatment during the fourteenth week.

Results of this study indicated that students in the peer instructional group performed significantly better than the students in the other two groups. Further research investigating intensive use of flipping classroom and peer instructional approaches with modifications is needed to measure the effectiveness of their use in the classroom.

References

- Al-Refai, M., Alshannag, Q., & Syam, M. (2014). Improving the Learning Process of Calculus Using Modern Technology. The iPad Experiment, *SCITEED2014 conference*, April 24-28, Turkey.
- Bates, S., & Galloway, R. (2012). The inverted classroom in a large enrolment introductory physics course: A case Study. *HEA STEM Conference*, London, UK.

- Batista, S., Behar, P., & Passerino, L. (2013). Activity Theory and M-Learning. *The Teaching of Ubiquitous and Mobile Learning in the Digital Age*, 93-108.
- Carlisle, M.C. (2010). Using you tube to enhance student class preparation in an introductory Java course. *The 41st ACM Technical Symposium on Computer science Education*; Mar 10–13, Milwaukee, WI.
- Carter, P. (2012). An experience report: on the use of multimedia pre-instruction and just-in-time teaching in a CS1 course. *The 43rd ACM Technical Symposium on Computer Science Education*; Feb 29–March 3, Raleigh, NC.
- Demetry, C. (2010). Work in progress – An innovation merging ‘classroom flip’ and team- based learning. *The 40th ASEE/IEEE Frontiers in Education Conference*, Washington, DC.
- Deslauriers, L., Schelew, E., & Wieman, C. (2011). Improved learning in a large enrollment physics class. *Science*, 332, 862–864.
- Ellison, M. (1993). The effect of computer and calculator graphics on students' ability to mentally construct calculus concepts, Doctoral dissertation, University of Minnesota, *Dissertation Abstracts International*, 54, 4020A.
- Estela Carbonell, M., Saà Seoane, J. (2009). *A calculus course with interactive support on Moodle*. *International Technology, Education and Development Conference*, Valencia.
- Frydenberg, M. (2012). Flipping Excel. *The Information Systems Educators Conference*, New Orleans, LA.
- Gannod, G., Burge, J. & Helmick, M. (2008). Using the inverted classroom to teach Software Engineering. *The 30th International Conference on Software Engineering*, New York: ACM. 777-786.
- Gok, T. (2012). The impact of peer instruction on college students’ beliefs about physics and conceptual understanding of electricity and magnetism. *International Journal of Science and Mathematics Education*, 10, 417-436.
- Hoffmann, L., Bradley, G., Sobecki, D., & Price, M. (2013). *Calculus for Business, Economics, and the Social and Life Sciences*, Brief Edition, 11th Ed. by, McGraw-Hill.
- Hohenwarter, M., Hohenwarter, J., Kreis, Y., & Lavicza, Z. (2008). Teaching and Learning Calculus with Free Dynamic Mathematics Software GeoGebra. *11th International Congress on Mathematical Education*, Monterrey, Mexico, 1-9.
- Kadry, S., & El Shalkamy, M. (2012). Toward new vision in teaching calculus. *IERI Procedia*, 548-553.
- Lage, M., Platt, G., & Treglia, M. (2000). Inverting the classroom: A gateway to creating an inclusive learning environment. *The Journal of Economic Education*. 31(1): 30–43.
- Lucas, A. (2009). Using peer instruction and i-clickers to enhance student participation in Calculus. *PRIMUS: Problems, Resources and Issues in Mathematics Undergraduate Studies*, 19:3, 219-231.
- Mazur, E. (1997). *Peer Instruction: A User's Manual*. Series in Educational Innovation, Prentice Hall, Upper Saddle River, NJ.
- Mazur, E. (2012). The flipped classroom will redefine the role of educators.
- Moravec, M., Williams, A., Aguilar-Roca, N., & O’Dowd, D. (2010). Learn before lecture: A strategy that improves learning outcomes in a large introductory biology class. *CBE-Life Sciences Education*. 9(4): 473–481.
- Pilzer, S. (2001). Peer instruction in physics and mathematics. *PRIMUS: Problems, Resources and Issues in Mathematics Undergraduate Studies*, 11:2,185-192.
- Serhan, D., & Syam, M. (2011). Using Concept Maps as an Instructional Tool in Calculus. *International Journal of Instructional Media*, 38(1), 79-85.
- Strayer, J. F. (2007). *The effects of the classroom flip on the learning environment: A comparison of learning activity in a traditional classroom and a flip classroom that used an intelligent tutoring system*, Columbus, OH: Ohio State University. (Unpublished doctoral dissertation)
- Strayer, J. (2012). How learning in an inverted classroom influences cooperation, innovation and task orientation. *Learning Environments Research*, 15(2): 171–193.
- Talbert, R. (2012). Learning MATLAB in the inverted classroom. *Computers in Education Journal*. 23(2), 50-60.
- Toto, R., & Nguyen, H. (2009). Flipping the work design in an industrial engineering course. *The Frontiers in Education Conference*. San Antonio, TX.

Author Information

Muhammed Syam

United Arab Emirates University
AlAin, UAE

Contact E-mail: *m.syam@uaeu.ac.ae*

Derar Serhan

Arizona State University
Arizona, USA

Farouq Almeqdadi

Emirates College for Advanced Education
Abu Dhabi, UAE

A Study on University Students' Online Information Search Strategies and Lifelong Learning Situations

Baris EMLEK
Selçuk University

Ahmet Oguz AKTURK
Necmettin Erbakan University

Abstract: The purpose of the present study is to determine university students' online information search strategies and lifelong learning situations and investigate the relationships between them. In addition, the students' online information search strategies and lifelong learning situations were investigated in terms of their gender and frequency of online information search. A total of 276 students attending a university in a large city in central Turkey participated in the study on a voluntary basis. The research data were collected using "Online Information Searching Strategies Scale" and "Lifelong learning Scale". Descriptive statistics, correlation analysis, independent samples t test analysis and one-way variance analysis were used to analyze the data obtained in this study, which was conducted in accordance with the procedures of relational survey and causal-comparative research. According to the findings of the study, it was found that university students' online information search strategies were below the average in the disorientation factor whereas they were above the average in the evaluation, purposeful thinking, select main ideas, trial & error, control and problem solving factors. On the other hand, it was found that university students' lifelong learning levels were above the average. According to another finding of the study, all the correlations between university students' online information search strategies and lifelong learning levels were statistically significant and positive. Moreover, it was found that male students' averages of online information search strategies were significantly higher than those of the female students in the disorientation, evaluation, purposeful thinking, control and problem solving factors, but that there was not a significant difference in their lifelong learning levels in terms of gender. In addition to this, it was found that the online information search strategies and lifelong learning levels of university students who searched information on the internet very frequently (except for purposeful thinking, select main ideas and control factors) were higher than those who seldom searched information on the internet.

Keywords: Online information search strategies, Lifelong learning, Gender

Üniversite Öğrencilerinin Çevrimiçi Bilgi Arama Stratejilerinin ve Yaşam Boyu Öğrenme Durumlarının İncelenmesi

Özet: Bu çalışmada üniversite öğrencilerinin çevrimiçi bilgi arama stratejileri ile yaşam boyu öğrenme durumlarının belirlenmesi ve bunların arasındaki ilişkilerin incelenmesi amaçlanmaktadır. Ayrıca çalışmada öğrencilerin çevrimiçi bilgi arama stratejileri ile yaşam boyu öğrenme durumları cinsiyet ve internette bilgi arama sıklığı açısından incelenmiştir. Araştırmaya Türkiye'nin orta kesimindeki büyük bir ildeki üniversitede öğrenim gören toplam 276 öğrenci gönüllülük esasına göre katılmıştır. Araştırmanın verileri "Çevrimiçi Bilgi Arama Stratejileri Ölçeği" ve "Yaşam Boyu Öğrenme Ölçeği" aracılığıyla toplanmıştır. İlişkisel tarama ve nedensel karşılaştırma prosedürlerine uygun olarak yürütülen bu araştırmanın verilerinin analizinde betimsel istatistikler, korelasyon analizi, bağımsız örneklem t-testi analizi ve tek yönlü varyans analizi kullanılmıştır. Araştırmanın bulgularına göre, üniversite öğrencilerinin çevrimiçi bilgi arama stratejilerinin kaybolma faktöründe ortalamanın altında; değerlendirme, amaçlı düşünme, temel fikirleri ayırt etme, deneme yanılma, kontrol ve problem çözme faktörlerinde ise ortalamanın üzerinde olduğu belirlenmiştir. Üniversite öğrencilerinin yaşam boyu öğrenme düzeylerinin ise ortalamanın üzerinde olduğu tespit edilmiştir. Çalışmanın bir diğer bulgusuna göre, üniversite öğrencilerinin çevrimiçi bilgi arama stratejileri ile yaşam boyu öğrenme düzeyleri arasındaki tüm korelasyonlar istatistiksel olarak anlamlı ve pozitifdir. Ayrıca, erkek öğrencilerin çevrimiçi bilgi arama stratejilerinin kaybolma, değerlendirme, amaçlı düşünme, kontrol ve problem çözme faktörlerinde kadın öğrencilere göre anlamlı düzeyde daha yüksek ortalamalara sahip olduğu; yaşam boyu öğrenme düzeylerinde ise cinsiyet açısından anlamlı bir farklılığın olmadığı bulunmuştur. Bunun yanı sıra genel olarak, internette çok sık ve sık bilgi arayan üniversite öğrencilerinin çevrimiçi bilgi arama stratejilerinin (amaçlı düşünme, temel fikirleri ayırt etme ve kontrol faktörleri hariç) ve yaşam boyu öğrenme düzeylerinin internette nadiren bilgi arayanlara göre daha yüksek olduğu bulunmuştur.

Anahtar Kelimeler: Çevrimiçi bilgi arama stratejileri, Yaşam boyu öğrenme, Cinsiyet

Giriş

Günümüzde bilim ve teknolojinin giderek artan bir hızda gelişmesinin bir sonucu olarak kültürel değişimlerin de çok hızlı gerçekleştiği görülmektedir. Bu hızlı değişime bireylerin ayak uydurma gereksinimleri sürekli öğrenme ihtiyacını doğurmaktadır. İnsan var olduğu günden beri gelişiyor, değişiyor ve bunun için de öğreniyor. Toplumlar için öğrenme sonlu bir süreç olmamakla birlikte bireyler için de yaşam süresi boyunca süregelen ihtiyaç halini almaktadır. Geçen yüzyılın sonlarından itibaren ortaya çıkan ve popüler hale gelen internet ve bunun ürünü olan web siteleri günümüzde öğrenme ortamlarının ilk sırasında yer almaktadır. Kısaca bireylerin hayat boyu öğrenme eğilimleri giderek artmakta ve bunun için öğrenme ortamları aramaktadır. Günümüzde ise bu ihtiyaçları karşılayabilecek ortamların başında da çevrimiçi bilgi arama ortamları gelmektedir. Cobern (2015) günümüzde çeşitli bilgi iletişim teknolojilerinin kullanımının arttığını ve bu durumun da yaşam boyu öğrenme üzerindeki etkilerinin kaçınılmaz olduğunu belirtmiştir. Elbette bu ortamlarda doğru bilgiye hızlı şekilde ulaşabilmenin belirli kuralları ve stratejileri vardır. Bu stratejileri belirlemede bilgi arayanın kimliği, ne tür bilgi aradığı, ne amaçla arama yaptığı, hangi web ortamlarında yaptığı, sonuca ulaşamama durumunda ne gibi davranışlar sergilediği önemli problemler oluşturmakta ve bu problemlere karşı çözümler üretilmektedir.

Yaşam Boyu Öğrenme (YBÖ)

YBÖ kavramını ilk olarak 1800'lü yıllarda Grundtvig ortaya atmıştır (Wain, 2000). Kavramın ortaya çıkmasında insanların sürekli kendini yenileme ve geliştirme çabası söz konusudur (Lambeir, 2005). İlerleyen yıllarda farklı bilim insanları YBÖ için benzer tanımlamalar yapmışlardır. Kulich (1982) YBÖ'yi bireye yaşamı boyunca eğitimin sunulması olarak tanımlarken, White (1982) ise bireylerin yaşamlarını yönetebilmeleri için doğumdan ölüme kadar devam eden gerekli öğrenme etkinlikleri olarak ifade etmiştir. Commission of the European Communities (2000)'e göre yaşam boyu öğrenme, kişisel, toplumsal, sosyal ve/veya iş yaşamı çerçevesinde bilgi, beceri ve yetilerin geliştirilmesi amacıyla yapılan, ister örgün ister yaygın veya doğal, sürekli devam eden, bütün amaçlı öğrenme etkinliklerini kapsar. YBÖ'de öğrenmenin zaman ve mekân sınırı yoktur. Öğrenme isteğinin olduğu her yerde gerçekleşebilmelidir. Günümüzde zaman ve mekânla sınırlı kalmadan öğrenme ortamı oluşturabileceğimiz en önemli mecra çevrimiçi bilgi arama ortamlarıdır. Bu açıdan çevrimiçi bilgi arama ortamları YBÖ için yadsınamaz bir öneme sahiptir.

Çevrimiçi Bilgi Arama Stratejileri (ÇBAS)

Geçmişte bilgi edinme araçlarının başında yazılı basım kaynakları gelirken günümüzde bunun yerini bilgi iletişim teknolojileri almaktadır. Bu teknolojilerin bilgi arama yöntemlerine dâhil olmasıyla birlikte bir takım problemlerde ortaya çıkmıştır (Sırakaya ve Çakır, 2014). Çevrimiçi ortamlar zengin bilgi kaynakları sunmalarına rağmen bu ortamda amaçlı bilgi arama zor ve karmaşık bir olaydır. Bilgiye ulaşmak için girilen çevrimiçi ortamda bazen kaybolma, çıkmaza girme, kontrolü kaybetme, umutsuzluğa düşme gibi sorunlar ortaya çıkmaktadır (Aşkar ve Mazman, 2013; Debowski, 2001; Tsai, 2009). Çevrimiçi ortamda her türlü bilgiye ulaşılabilir. Fakat bu bilgi kaynağı durmadan yenilenmekte, içeriği arttırılmakta ve bu bilginin doğruluğu sorgulanmadan çevrimiçi ortama aktarılmaktadır. Çevrimiçi ortamlarda bilgiyi paylaşmanın da bilgiye ulaşmanın da kimliği nihayetinde sorgulanmamaktadır. Bu durum da çevrimiçi ortamlardaki bilginin doğruluğunu ve niteliğini sorgulanır hale getirmektedir (Nazim, 2008). Yani çevrimiçi ortamlardaki bilgiye ulaşma bir beceri ve strateji gerektirirken aynı zamanda ulaşılan bilginin niteliğinin de birey tarafından sorgulanması gerekmektedir. Lorenzen (2002)'in yapmış olduğu bir araştırma, öğrencilerin çevrimiçi ortamda ulaştıkları bilgiler arasında nitelikli olanı seçme ve bilgi hakkında karar verme konusunda zorluk yaşadıklarını göstermektedir.

Tsai ve Tsai (2003) çevrimiçi ortamda bilgi arama stratejilerinin karmaşık bir süreç olduğundan bahsederlerken bu süreci üçe ayırmaktadırlar.

- Davranışsal alan (kontrol ve kaybolma)
- Yaklaşımsal alan (deneme-yanılma, problem çözme ve amaçlı düşünme)
- Üst bilişsel alan (temel fikirleri ayırt etme ve değerlendirme)

Bilgi arama amaçlarının çevrimiçi ortamda arama stratejilerine etkisinin olduğu söylenmektedir. Tsai, Liang, Hou ve Tsai (2012) yaptıkları çalışmada öğrenme amacıyla yapılan arama ve günlük yaşamla ilgili bilgi edinme amacıyla yapılan arama stratejilerinin rolünü incelemiştir. Elde ettikleri sonuca göre günlük yaşama dair bilgi arama stratejilerinin öğrenme için yapılan bilgi arama stratejilerine oranla anlamlı şekilde yüksek olduğu bulunmuştur. Bu sonuçlardan elde edilen çıkarımlara göre özellikle çevrimiçi ortamlarda bilgi arama stratejilerinin günlük yaşamla entegre şekilde tasarlanması gerektiği vurgulanmıştır.

Araştırmanın Amacı ve Önemi

Bu çalışmada üniversite öğrencilerinin çevrimiçi bilgi arama stratejileri ile yaşam boyu öğrenme durumlarının belirlenmesi ve bunların arasındaki ilişkilerin incelenmesi amaçlanmaktadır. Ayrıca, çalışmada öğrencilerin çevrimiçi bilgi arama stratejileri ile yaşam boyu öğrenme durumları cinsiyet ve internette bilgi arama sıklığı açısından incelenmiştir. Alan yazın tarandığında çevrimiçi bilgi arama stratejileri ile yaşam boyu öğrenme durumları arasındaki ilişkinin incelenmediği görülmüştür. Bu açıdan çalışma önem kazanmaktadır. Ayrıca edilen sonuçlar da bu araştırmanın önemini ortaya koymaktadır.

Yöntem

Araştırma Modeli

Bu çalışmada, üniversite öğrencilerinin çevrimiçi bilgi arama stratejileri ile yaşam boyu öğrenme durumlarının belirlenmesi ve bunların arasındaki ilişkileri ortaya koyulabilmesi için ilişkisel tarama ve nedensel karşılaştırma prosedürleri kullanılmıştır. İlişkisel tarama, tarama modelinin bir türü olup araştırmaya konu olan durum veya olayı mevcut şartlarında inceler ve araştırmadaki değişkenler arasında bir ilişkinin olup olmadığını sınırlar (Johnson, 2001). Nedensel karşılaştırma araştırmalarında ise, en az iki değişken arasında bağımsız değişkene göre gruplar oluşturularak bağımlı değişkene göre gruplar arasında fark olup olmadığı incelenir (Karasar, 2006).

Çalışma Grubu

Araştırmanın katılımcıları Konya ili merkezinde bulunan bir üniversitenin farklı bölümlerinde öğrenim gören öğrencilerden gönüllülük esasına göre belirlenmiştir. Araştırmaya katılan öğrenci grubu ile ilgili istatistikî bilgiler Tablo 1’de verilmiştir.

Tablo 1. Çalışma grubunu demografik özellikleri

Değişken	Seçenek	n	f (%)
Cinsiyet	Kadın	147	53.3
	Erkek	129	46.7
İnternette Bilgi Arama Sıklığı	Çok Sık	164	59.4
	Sık	55	19.9
	Nadiren	57	20.7

Tablo 1’de verilen değerler incelendiğinde, araştırmaya katılan öğrencilerin %53.3’ünün kadın öğrencilerden %46.7’sinin de erkek öğrencilerden oluştuğu görülmektedir. Bu öğrencilerin internette bilgi arama sıklığına bakıldığında ise öğrencilerin %59.4’ünün çok sık, %19.9’unun sık ve %20.7’sinin de nadiren internette bilgi aradığı anlaşılmaktadır.

Veri Toplama Araçları

Araştırmanın verileri iki farklı ölçek ile toplanmıştır. Aşağıda bu ölçekler ile ilgili detaylı bilgiler sunulmaktadır.

Çevrimiçi Bilgi Arama Stratejileri (ÇBAS) Ölçeği

Araştırmaya katılan öğrencilerin çevrimiçi bilgi arama stratejilerini belirlemek için Tsai (2009) tarafından geliştirilen ve Türkçe uyarlaması Aşkar ve Mazman (2013) tarafından yapılan “Çevrimiçi Bilgi Arama Stratejileri Ölçeği” kullanılmıştır. ÇBAS ölçeği 25 madde ve yedi alt boyuttan (1:Kaybolma, 2:Değerlendirme, 3:Amaçlı düşünme, 4:Temel fikirleri ayırt etme, 5:Deneme yanılma, 6:Kontrol, 7:Problem çözme) oluşmaktadır. Ölçeğin tümünün Cronbach Alpha güvenirlik katsayısı .910, McDonald ω (omega) katsayısı ise .942 olarak bulunmuştur. ÇBAS ölçeğinin maddeleri 6’lı likert tipinde olup, 1.Bana hiç uygun değil ile 6.Bana tamamen uygun arasında cevaplandırılabilir.

Yaşam Boyu Öğrenme (YBÖ) Ölçeği

Araştırmaya katılan öğrencilerin yaşam boyu öğrenme becerilerini belirlemek için Wielkiewicz ve Meuwissen (2014) tarafından geliştirilen ve Türkçe uyarlaması Engin, Kör ve Erbay (2016) tarafından yapılan “Yaşam Boyu Öğrenme Ölçeği” kullanılmıştır. YBÖ ölçeği 15 maddeden oluşmaktadır. Bu ölçeğin güvenirlik çalışması

sonucunda ölçeğin geneli için Cronbach Alpha güvenilirlik katsayısı .93 olarak bulunmuştur. YBÖ ölçeğinin maddeleri 5'li likert tipinde olup, 1.Asla ile 5.Her zaman arasında cevaplandırılabilirlerdir.

Bulgular

Üniversite Öğrencilerinin ÇBAS ve YBÖ Düzeyleri

Üniversite öğrencilerinin ÇBAS ve YBÖ düzeylerine göre hesaplanan ortalama puan sonuçları Tablo 2'de gösterilmiştir.

Tablo 2. Üniversite öğrencilerinin ÇBAS ve YBÖ düzeyleri

Ölçek	Faktör	N	Min.	Mak.	\bar{X}	SS
ÇBAS	Kaybolma	276	1	6	3.30	1.318
	Değerlendirme	276	1	6	4.42	0.911
	Amaçlı Düşünme	276	1	6	4.58	0.887
	Temel Fikirleri Ayırt Etme	276	1	6	4.56	0.972
	Deneme Yanılma	276	1	6	4.58	0.932
	Kontrol	276	1	6	4.50	0.823
	Problem Çözme	276	1	6	4.32	0.779
YBÖ		276	1	5	3.81	0.557

Tablo 2'de görüldüğü üzere öğrencilerin ÇBAS düzeylerinin kaybolma ($\bar{X}=3.30$) faktörü hariç tüm faktörlerde (Değerlendirme [$\bar{X}=4.42$], Amaçlı düşünme [$\bar{X}=4.58$], Temel Fikirleri Ayırt Etme [$\bar{X}=4.56$], Deneme Yanılma [$\bar{X}=4.58$], Kontrol [$\bar{X}=4.50$]ve Problem Çözme [$\bar{X}=4.32$]) ortalamasının üzerinde olduğu belirlenmiştir. Yine aynı tabloda öğrencilerin YBÖ düzeylerinin ($\bar{X}=3.81$) ortalamasının üzerinde olduğu belirlenmiştir.

Üniversite Öğrencilerinin ÇBAS ile YBÖ Düzeyleri Arasındaki İlişkiler

Üniversite öğrencilerinin ÇBAS ile YBÖ düzeyleri arasındaki ilişkinin analizinde Pearson Momentler Çarpım Korelasyonu kullanılmıştır ve analiz sonucunda elde edilen değerler Tablo 3'te gösterilmiştir.

Tablo 3. Üniversite öğrencilerinin ÇBAS düzeyleri ile YBÖ düzeyleri arasındaki ilişkiler

Değişken	1	2	3	4	5	6	7	8
1. Kaybolma	–							
2. Değerlendirme	.181**	–						
3. Amaçlı Düşünme	.219**	.810**	–					
4. Temel Fikirleri Ayırt Etme	.129*	.726**	.727**	–				
5. Deneme Yanılma	.124*	.656**	.633**	.668**	–			
6. Kontrol	.127*	.776**	.632**	.726**	.643**	–		
7. Problem Çözme	.348**	.609**	.597**	.462**	.492**	.552**	–	
8. Yaşam Boyu Öğrenme	.405**	.527**	.475**	.477**	.410**	.415**	.295**	–

** : Korelasyon 0.01 düzeyinde anlamlı (2-yönlü).

* : Korelasyon 0.05 düzeyinde anlamlı (2-yönlü).

Tablo 3'ten de görülebileceği gibi üniversite öğrencilerinin ÇBAS (Kaybolma, Değerlendirme, Amaçlı Düşünme, Temel Fikirleri Ayırt Etme, Deneme Yanılma, Kontrol ve Problem Çözme) ile YBÖ düzeyleri arasındaki tüm korelasyonlar istatistiksel olarak anlamlı ve pozitif yönlüdür.

Üniversite Öğrencilerinin ÇBAS ve YBÖ Düzeylerinin Cinsiyete Göre İncelenmesi

Üniversite öğrencilerinin ÇBAS ve YBÖ düzeylerinin cinsiyete göre incelenmesinde t-testi analizi kullanılmış olup analiz sonuçları Tablo 4'te verilmiştir.

Tablo 4. Üniversite öğrencilerinin ÇBAS ve YBÖ düzeylerinin cinsiyete göre değişimlerinin analiz sonuçları

Ölçek	Faktör	Cinsiyet	N	\bar{X}	SS	t	p
ÇBAS	Kaybolma	Kadın	147	3.13	1.27	-2.181	.030
		Erkek	129	3.48	1.35		

Değerlendirme	Kadın	147	4.24	0.97	-3.513	.000
	Erkek	129	4.62	0.80		
Amaçlı Düşünme	Kadın	147	4.43	0.98	-2.942	.003
	Erkek	129	4.74	0.74		
Temel Fikirleri Ayırt Etme	Kadın	147	4.49	0.97	-1.265	.207
	Erkek	129	4.64	0.97		
Deneme Yanılma	Kadın	147	4.49	1.04	-1.558	.114
	Erkek	129	4.67	0.79		
Kontrol	Kadın	147	4.36	0.84	-2.906	.004
	Erkek	129	4.64	0.77		
Problem Çözme	Kadın	147	4.22	0.85	-2.350	.018
	Erkek	129	4.44	0.68		
YBÖ	Kadın	147	3.75	0.60	-1.660	.098
	Erkek	129	3.87	0.56		

Tablo 4'ü incelediğimizde, ÇBAS ölçeğinin Kaybolma, Değerlendirme, Amaçlı Düşünme, Kontrol ve Problem Çözme faktörlerinde erkek öğrencilerin lehine anlamlı düzeyde bir farklılığın olduğu görülürken, Temel Fikirleri Ayırt Etme ve Deneme Yanılma faktörlerinde ise erkek öğrenciler daha yüksek ortalama puanlara sahip olmasına rağmen ortalama puanlar arasındaki bu farklılıkların anlamlı düzeyde olmadığı görülmektedir. Öğrencilerin YBÖ düzeylerinde ise yine erkek öğrencilerin ortalama puanları kadınlara göre daha yüksek olmasına rağmen ortalama puanlar arasındaki bu farklılığın anlamlı düzeyde olmadığı tespit edilmiştir.

Üniversite Öğrencilerinin ÇBAS ve YBÖ Düzeylerinin İnternette Bilgi Arama Sıklığına Göre İncelenmesi

Ortaokul öğrencilerinin ÇBAS ve YBÖ düzeylerinin internette bilgi arama sıklığına göre farklılaşma durumları tek yönlü varyans analizi (ANOVA) ile analiz edilmiştir. Analiz sonuçları Tablo 5'te verilmiştir.

Tablo 5. Üniversite öğrencilerinin ÇBAS ile YBÖ düzeylerinin internette bilgi arama sıklığı açısından analiz sonuçları

Ölçek	İnternette Bilgi Arama Sıklığı	N	\bar{X}	SS	F	p	Fark (Scheffe)
Kaybolma	Çok Sık	16	3.49	1.333	5.969	.003	Çok Sık > Nadiren
	Sık	55	3.24	1.198			
	Nadiren	57	2.80	1.269			
Değerlendirme	Çok Sık	16	4.51	0.869	4.453	.012	Çok Sık > Nadiren
	Sık	55	4.47	0.797			
	Nadiren	57	4.10	1.065			
Amaçlı Düşünme	Çok Sık	16	4.61	0.904	1.949	.144	
	Sık	55	4.68	0.826			
	Nadiren	57	4.38	0.876			
ÇBAS	Çok Sık	16	4.60	0.900	.482	.618	
	Sık	55	4.47	0.944			
	Nadiren	57	4.50	1.184			
Deneme Yanılma	Çok Sık	16	4.67	0.801	3.918	.021	Çok Sık > Nadiren
	Sık	55	4.59	0.836			
	Nadiren	57	4.27	1.265			
Kontrol	Çok Sık	16	4.57	0.828	2.209	.112	
	Sık	55	4.47	0.735			
	Nadiren	57	4.30	0.868			
Problem Çözme	Çok Sık	16	4.43	0.738	4.730	.010	Çok Sık > Nadiren
	Sık	55	4.21	0.738			
	Nadiren	57	4.09	0.877			
YBÖ	Çok Sık	16	3.93	0.553	15.876	.000	Çok Sık > Nadiren
	Sık	55	3.82	0.541			
	Nadiren	57	3.44	0.577			

Tablo 5 incelendiğinde, üniversite öğrencilerinin ÇBAS ölçeğinin Kaybolma [$F_{(2,273)}=5.969$; $p<.05$], Değerlendirme [$F_{(2,273)}=4.453$; $p<.05$], Deneme Yanılma [$F_{(2,273)}=3.918$; $p<.05$] ve Problem Çözme [$F_{(2,273)}=4.730$; $p<.05$] faktörlerinden ve YBÖ ölçeğinden [$F_{(2,273)}=15.876$; $p<.05$] aldıkları puanlarda internette bilgi arama sıklığı açısından anlamlı bir farklılık vardır. Farkı oluşturan temel etkinin hangi değişkenden geldiğini belirlemek için Scheffe testi uygulanmıştır. Scheffe testi sonuçlarına göre, ÇBAS ölçeğinin Kaybolma, Değerlendirme, Deneme Yanılma ve Problem Çözme faktörlerindeki farkın internette bilgi arama sıklığı çok sık ve nadiren olan öğrencilerden, YBÖ düzeylerindeki farkın ise internette bilgi arama sıklığı çok sık, sık ve nadiren olan öğrencilerden kaynaklandığı görülmektedir. Buna göre, internette çok sık bilgi arayan öğrencilerin nadiren bilgi arayanlara göre ÇBAS (Kaybolma, Değerlendirme, Deneme Yanılma ve Problem Çözme) düzeylerinin ve internette çok sık ve sık bilgi arayan öğrencilerin nadiren bilgi arayanlara göre de YBÖ düzeylerinin daha yüksek olduğu söylenebilir.

Tartışma ve Sonuç

Bu araştırma üniversite öğrencilerinin ÇBAS ve YBÖ düzeylerinin incelenmesi amacıyla büyük bir devlet üniversitesinde öğrenim görmekte olan 276 öğrencinin katılımı ile gerçekleştirilmiştir. Araştırma kapsamında toplanan verilerin analizi ile üniversite öğrencilerinin ÇBAS ve YBÖ düzeylerinin cinsiyet, bilgi arama sıklığı değişkenleri açısından farklılık gösterip göstermediği incelenmiştir. Araştırmada aynı zamanda ÇBAS'ın YBÖ ile ilişkisi de incelenmiştir.

Araştırma öncesinde literatür taramalarından elde edilen bilgiler doğrultusunda bilgi arama kaynağı olarak internetin öğrenciler tarafından çok fazla tercih edildiği belirlenmiştir. Lorenzen (2002) yaptığı bir çalışmada bireyin ilkokul döneminden başlayan ve devam eden birincil bilgi arama kaynağının internet olduğunu vurgulamıştır. Aynı çalışmada internetten bilgi arama yapan öğrencilerin çok iyi seviyede ÇBAS'a sahip olmadıkları vurgulanmıştır.

Araştırmadan elde edilen sonuçlara göre üniversite öğrencilerinin ÇBAS ölçeğinin yedi alt faktöründen sadece Kaybolma faktöründe ortalamasının altında; Değerlendirme, Amaçlı Düşünme, Temel Fikirleri Ayırt Etme, Deneme Yanılma, Kontrol ve Problem Çözme Faktörlerinde ise ortalamasının üzerinde olduğu görülmüştür. Bulunan bu sonucu destekler nitelikte Sırakaya ve Çakır (2014)'ın yapmış oldukları benzer bir çalışmada öğretmen adaylarının ÇBAS'nın sadece kaybolma alt faktöründe ortalama puanlarının düşük olduğu gözlemlenmiştir. Benzer bir sonuç da Dias, Gomes ve Correia (1999)'nın yaptığı çalışmada görülmüştür. Bu çalışmada çevrimiçi ortamdaki bilgi arama süreçlerinde farklı problemler yaşandığı ve bunların başında da internette kaybolma geldiğini ifade edilmektedir. Yaptığımız çalışmada üniversite öğrencilerinin YBÖ düzeylerinin ise ortalamasının üzerinde olduğu tespit edilmiştir. Bu sonuca göre üniversite öğrencilerinin öğrenmeyi sınırlı bir süreç olarak görmedikleri; bireyin var oluşundan yaşamının sonuna dek devam eden bir süreç olarak gördükleri söylenebilir. Kozikoğlu ve Altunova (2018) öğretmen adayları ile yürüttükleri bir çalışmada da öğretmen adaylarının yaşam boyu öğrenme eğilimlerinin çok yüksek düzeyde olduğunu tespit etmiştir.

Yaptığımız bu çalışmada elde edilen bir diğer sonuç da üniversite öğrencilerinin ÇBAS düzeyleri ile YBÖ düzeyleri arasındaki tüm korelasyonların pozitif yönde ve anlamlı olmasıdır. Cobern (2015)'in yaptığı bir çalışmada, her türlü bilgi iletişim teknolojisinin kullanımının arttığı günümüzde bu durumun YBÖ üzerine etkisinin yadsınmaz bir gerçek olduğu ve buna da doğru stratejiler sayesinde ulaşıldığı belirtmiştir.

Ayrıca, ÇBAS ölçeğinin Kaybolma, Değerlendirme, Amaçlı Düşünme, Kontrol ve Problem Çözme faktörlerinde erkek öğrencilerin lehine anlamlı düzeyde bir farklılığın olduğu görülürken, öğrencilerin YBÖ düzeylerinde ise yine erkek öğrencilerin ortalama puanları kadınlara göre daha yüksek olmasına rağmen ortalama puanlar arasındaki bu farklılığın anlamlı düzeyde olmadığı tespit edilmiştir. Burada elde edilen sonuçlara göre erkek öğrencilerin ÇBAS ölçeğinin Kaybolma, Değerlendirme, Amaçlı Düşünme, Kontrol ve Problem Çözme faktörlerinde kadın öğrencilere daha etkili stratejiler belirlemedeki sebeplerden biri erkek öğrencilerin teknolojik cihazlarla daha çok vakit geçirmeleri ve teknolojiye ulaşım imkânlarının kadınlara göre daha fazla olması gösterilebilir. Benzer bir yaklaşımda Schumacher ve Morahan-Martin (2001) tarafından ileri sürülmüş ve neden olarak da erkelerin teknolojik gelişmeleri kadınlara göre daha yakından takip etmelerini arama stratejilerini de etkilediğini belirtmişlerdir. Bu sonuçları destekleyen bazı çalışmalarda da katılımcıların cinsiyetlerine göre ÇBAS düzeylerinde erkekler lehine anlamlı farklılıklar tespit edilmiştir (Turan, Reisoğlu, Özçelik, & Göktaş, 2015; Tsai ve ark, 2012).

Son olarak araştırmada, internette çok sık bilgi arayan üniversite öğrencilerinin ÇBAS (Kaybolma, Değerlendirme, Deneme Yanılma ve Problem Çözme) düzeylerinin ve internette çok sık ve sık bilgi arayan öğrencilerin nadiren bilgi arayanlara göre de YBÖ düzeylerinin daha yüksek olduğu bulunmuştur. Sırakaya ve Çakır (2014)'ın yaptıkları bir çalışmada da internette bilgi arama sıklığının artmasıyla ÇBAS düzeylerinde de

artışın görüldüğü vurgulanmaktadır. Tsai ve Tsai (2003) tarafından yapılan çalışmada ise ÇBAS internet öz-yeterliği açısından incelenmiş ve internet öz-yeterliği yüksek olan öğrencilerin daha fazla arama stratejilerine sahip olduğu sonucuna ulaşılmıştır.

Kaynakça

- Aşkar, P., & Mazman, S. G. (2013). Çevrimiçi bilgi arama stratejileri envanterinin Türkçe'ye uyarlama çalışması. *Eğitim ve Bilim*, 38(168), 197-182.
- Coburn, W. W. (2015). The lifelong learning of science. *International Journal on Lifelong Education and Leadership*, 1(1), 1-10.
- Commission of the European Communities (2000). *A Memorandum on lifelong learning*. 13 Mart 2019 tarihinde http://arhiv.acs.si/dokumenti/Memorandum_on_Lifelong_Learning.pdf adresinden erişilmiştir.
- Debowski, S. (2001). Wrong way: Go back! An exploration of novice search behaviours while conducting an information search. *The Electronic Library*, 19, 371-382.
- Dias, P., Gomes, M. J., & Correia, A. P. (1999). Disorientation in hypermedia environments: Mechanisms to support navigation. *Journal of Educational Computing Research*, 20(2), 93-117.
- Engin, M., Kör, H., & Erbay, H. (2017). Yaşam boyu öğrenme ölçeği Türkçe uyarlama çalışması. *Kastamonu Eğitim Dergisi*, 25(4), 1561-1572.
- Johnson, B. (2001). Toward a new classification of nonexperimental quantitative research. *Educational Researcher*, 30(2), 3-13.
- Karasar, N. (2006). *Bilimsel araştırma yöntemleri*. Ankara: Nobel Yayıncılık.
- Kozikoğlu, İ., & Altunova, N., (2018). Öğretmen adaylarının 21. yüzyıl becerilerine ilişkin öz-yeterlik algılarının yaşam boyu öğrenme eğilimlerini yordama gücü. *Yükseköğretim ve Bilim Dergisi/Journal of Higher Education and Science*, 8(3), 522-531.
- Kulich, J. (1982) Lifelong education and the universities: A Canadian perspective. *International Journal of Lifelong Education*, 1(2): 123-142.
- Lambeir, B. (2005). Education as liberation: The politics and techniques of lifelong learning. *Educational Philosophy and Theory*, 37(3), 349-355.
- Lorenzen, M. (2002). The land of confusion? High school students and their use of the World Wide Web for research. *Research Strategies*, 18(2), 151-163.
- Nazim, M. (2008). Information searching behavior in the Internet age: A users' study of Aligarh Muslim University. *The International Information & Library Review*, 40(1), 73-81.
- Schumacher, P., & Morahan-Martin, J. (2001). Gender, internet and computer attitudes and experiences. *Computers in Human Behavior*, 17(1), 95-110.
- Sırakaya, M., & Çakır, H. (2014). Öğretmen adaylarının çevrimiçi bilgi arama stratejilerinin belirlenmesi. *Ahi Evran Üniversitesi Kırşehir Eğitim Fakültesi Dergisi*, 15(2), 191-206.
- Tsai, M. J. (2009). Online information searching strategy inventory (OISSI): A quick version and a complete version. *Computers & Education*, 53, 473-483.
- Tsai, M. J., & Tsai, C. C. (2003). Information searching strategies in web-based science learning: The role of Internet self-efficacy. *Innovations in Education and Teaching International*, 40(1), 43-50.
- Tsai, M. J., Liang, J. C., Hou, H. T., & Tsai, C. C. (2012). University students' online information searching strategies in different search contexts. *Australasian Journal of Educational Technology*, 28(5), 881-895.
- Turan, Z., Reisoğlu, İ., Özçelik, E., & Göktaş, Y. (2015). Öğretmenlerin çevrimiçi bilgi arama stratejileri. *Kastamonu Eğitim Dergisi*, 23(1), 1-16.
- Wain, K. (2000). The learning society: Postmodern politics. *International Journal of Lifelong Education*, 19(1), 36-53.
- White, J. (1982). *The aims of education re-stated*. London: Routledge & Kegan Paul.
- Wielkiewicz, R. M., & Meuwissen, A. S. (2014). A lifelong learning scale for research and evaluation of teaching and curricular effectiveness. *Teaching of Psychology*, 41(3), 220-227.

Investigation of Social Media Addiction of Middle School Students Skills

Ahmet Oguz AKTURK
Necmettin Erbakan University

Huseyin Seyhan DUYGU
Necmettin Erbakan University

Baris EMLEK
Selçuk University

Abstract: The purpose of this study is to determine middle school 5th, 6th, 7th and 8th grade students' social media addiction levels. Survey model was used as the research method. The data were collected from students attending a middle school on a voluntary basis. 162 middle school students attending a middle school in central Turkey participated in the study. "Social Media Addiction Scale-Student Form (SMAS-SF)", which is a five-item likert scale consisting of 29 items and 4 sub-dimensions, was used to collect the research data. Descriptive statistics, correlation analysis, independent samples t test analysis and one-way variance analysis were used to analyze the data obtained within the scope of the study. As a result of the study, it was seen that middle school students generally exhibited a low level of social media addiction and that social media addiction levels of male students were higher than those of female students. Moreover, when the students' social media addiction levels were investigated in terms of their smart phone ownership, it transpired that social media addiction levels of students with smart phones were generally higher than those who did not have smart phones. In addition to this, it was observed that social media addictions of students who used Instagram most frequently as social network site were higher than students who used Facebook; also, social media addictions of students who had had social media membership for more than three years were higher than those of students who had had social network site membership between 0 to 1 year. Finally, it was found that as the number of social network site friends of middle school students and their frequency of using social network sites increased, their social media addictions also increased.

Keywords: Internet, Technology, Social media addiction, Middle school students

Ortaokul Öğrencilerinin Sosyal Medya Bağımlılıklarının İncelenmesi

Özet: Bu çalışmanın amacı, ortaokul 5, 6, 7 ve 8. sınıf öğrencilerinin sosyal medya bağımlılık düzeylerini belirlemektir. Araştırma yöntemi olarak genel tarama modeli kullanılmıştır. Veriler bir ortaokulda öğrenim gören öğrencilerden gönüllülük esasına göre toplanmıştır. Araştırmaya Türkiye'nin orta kesimindeki büyük bir ilde bulunan bir ortaokulda öğrenim gören 162 ortaokul öğrencisi katılmıştır. Araştırmanın verilerini toplamak için 5'li Likert tipinde, 29 madde ve 4 alt boyuttan oluşan "Sosyal Medya Bağımlılığı Ölçeği-Öğrenci Formu (SMBÖ-ÖF)" kullanılmıştır. Araştırma kapsamında elde edilen verilerin analizinde betimsel istatistikler, korelasyon analizi, bağımsız örneklem t-testi analizi ve tek yönlü varyans analizi kullanılmıştır. Araştırma sonucunda, ortaokul öğrencilerinin genel olarak düşük düzeyde sosyal medya bağımlılığı sergiledikleri ve erkek öğrencilerin sosyal medya bağımlılık düzeylerinin kız öğrencilere göre daha yüksek olduğu görülmüştür. Ayrıca, öğrencilerin akıllı telefona sahip olma durumlarına göre sosyal medya bağımlılık düzeyleri incelendiğinde akıllı telefonu olan öğrencilerin sosyal medya bağımlılık düzeylerinin akıllı telefonu olmayanlara göre genel olarak daha yüksek olduğu ortaya çıkmıştır. Bunun yanında, sosyal ağ sitesi olarak en sık Instagram'ı kullanan öğrencilerin sosyal medya bağımlılıklarının Facebook'u kullanan öğrencilere göre daha yüksek olduğu görülmüşken; 3 yıldan fazla süredir sosyal ağ sitesi üyesi olan öğrencilerin sosyal medya bağımlılıklarının 0-1 yıl arasında sosyal ağ sitesi üyesi olan öğrencilere göre daha yüksek olduğu görülmüştür. Son olarak, ortaokul öğrencilerinin sosyal ağ sitesi arkadaş sayısı ve sosyal ağ sitesi kullanma sıklığı arttıkça sosyal medya bağımlılıklarının da arttığı görülmektedir.

Anahtar Kelimeler: İnternet, Teknoloji, Sosyal medya bağımlılığı, Ortaokul öğrencisi

Giriş

Günümüzde internet teknolojilerinin yaygınlaşp gelişmesiyle birlikte çocuklarda ve ergenlik çağındaki gençlerde internet kullanımının giderek arttığı görülmektedir. Bilgisayar ve internet, sadece yetişkinler için

değil; aynı zamanda çocuklar ve gençler için de oldukça faydalı bir ortamdır. Çocukların ve gençlerin bir iletişim, eğlence ve eğitim aracı olarak internetten doğru ve etkin bir şekilde faydalanması adına ebeveynler, teknolojiyi verimli kullanma ve bilgiye daha çabuk, doğru ve etkin bir şekilde ulaşmak için çocuklarına bu imkânları sunmak istemektedirler (Canberk ve Sağıroğlu, 2007).

Türkiye’de internet kullanımı hızlı bir şekilde yaygınlaşmaktadır. Özellikle çocuklar ve gençler bu yeni teknolojiye yoğun ilgi göstermekte ve küçük yaştan itibaren etkin bir şekilde kullanmaktadır. Bilgisayar ve internetin neredeyse tüm evlerde olması kullanıcı kitlesinin internete erişimini kolaylaştırmaktadır. Ancak bu hızla gelişmekte olan teknolojinin eğitici olmasının yanı sıra, genç ve çocuklar için uygun olmayan içeriği ve kullanım amacı da endişe yaratmaktadır (Yüksel ve Baytemir, 2010).

Kent yaşamının bir sonucu olarak günümüz toplumlarındaki sosyal bağlar giderek zayıflamaktadır. Sanal iletişim özellikle ergenlerin en önemli iletişim aracı haline gelmiştir. Yapılan araştırmalarda insanların sosyal bağlarını sosyal ağlar üzerinden kurmaya çalışmaları, sosyal ağlar aracılığıyla tanımadığı kişilerle kolay bir şekilde iletişim içinde bulunabilmeleri, düşüncelerini ve duygularını özgürce ifade edebilmeleri, göstermek istedikleri özelliklerini abartarak gösterebilmeleri ve internet üzerindeki sosyal ağ ortamlarında diğerlerini gözetleme fırsatını bulmaları sosyal medya bağımlılığının nedenleri olarak gösterilmiştir. Amacı bilgi paylaşımını kolaylaştırmak ve iletişimi arttırmak olan internetin yaygınlaşması ile bazı sorunlar ortaya çıkmıştır. Bunlardan biriside sosyal medya bağımlılığıdır. Genel olarak bağımlılık, bir madde kullanıp o maddeyi bırakamama ya da bir davranışı kontrol etmek istese de edememe şeklinde tanımlanmaktadır (Egger ve Rauterberg, 1996).

Sigara, alkol, uyuşturucu gibi birçok maddeyi zararlı madde bağımlılığı olarak adlandırabiliriz. Ancak bağımlılık denince akla sadece zararlı madde bağımlılığı gelmemelidir. Fiziksel olarak bir maddeye dayanmayan pek çok bağımlılık türü de mevcuttur. Bunlar arasında; davranış tabanlı yeme ve içme bağımlılığı, bilgisayar oyunları bağımlılığı, bilgisayar bağımlılığı, akıllı telefon, tablet ve televizyon bağımlılığı, alışveriş bağımlılığı, internet bağımlılığı, sosyal medya bağımlılığı vb. sayılabilir (DiMaggio, Hargittai, Neuman ve Robinson, 2001; Griffiths, 1999; Kim ve Kim, 2002).

Sosyal medya bağımlılığı bir tür internet bağımlılığı olarak kabul edilir. İnternet bağımlılığı her yaştan ve gruptan bireyin ortak problemi olmasına karşın, bağımlıların çoğunu erkeklerin ve gençlerin oluşturduğu söylenebilir (Gonzalez, 2002). İnternet bağımlılığı, psikiyatrik bir hastalık olduğunu savunan bazı kişilerce ele alınmış ve internet bağımlısı olan hastalara tedaviler uygulanmış, olumlu sonuçlar alınmıştır (Koroğlu, Öztürk, Tellioglu, Genç, Mırsal ve Beyazyürek, 2006; Murali ve George, 2007; Young ve Rodgers, 1998). Ancak, her madde bağımlılığı da her davranış bağımlılığı da bağımlılıkla sonuçlanmayabilir (Caplan, 2005).

Sosyal medya kullanımının bir bağımlılık olarak görülmesindeki nedenlerden biri “kullanım miktarı” ya da internette yani sosyal medyada geçirilen çevrim içi olarak harcanan zamandır (Chou, Condron ve Belland, 2005). Sosyal medyada çevrim içi olarak uzun zaman geçirmek internet bağımlılığının da nedenleri arasında yer almaktadır (Irwansyah, 2005). İnternet bağımlılığının belirlenmesinde sosyal medyada çevrim içi olarak geçirilen zaman değil, bu zamanın ne kadar doğru ve ne için kullanıldığı da çok önemlidir. İnternetteki çevrim içi aktif geçirilen süre kullanım amacına göre olumlu veya olumsuz olarak sonuçlanır (Bayraktutan, 2005). İnternet bağımlısı olan bireyler ya da ergenler, oyun, müzik, film, sohbet siteleri, pornografik siteler, sosyal paylaşım siteleri gibi yerlerde daha çok zamanlarını geçirmektedirken, internet bağımlısı olmayan bireyler ve ergenler, haber siteleri, eğitici belgeseller ve eğitim sitelerinde zaman geçirmektedirler (Kim ve Kim 2002).

Chou ve Hsiao (2000) internete bağımlı olan insanları gözlemleyerek bazı koşullar belirlemiş ve bu koşulları sağlayan bireylerin internet bağımlısı olarak düşünülebileceğini ifade etmişlerdir. Bu koşullar şunlardır;

- Bireyin hayatında en önemli yeri internet alırsa ve düşünmesinde baskın konuma gelirse
- İnternet “gerçek dünyadan kaçış” gibi görülürse
- Çok uzun süre çevrim içi aktif olarak internet başında geçirilirse
- Sosyal paylaşım sitelerinde her an çevrim içi olmadıklarında kendilerini mutsuz ya da rahatsız hissederlerse
- İnternet kullanımı ailelerinden çevresindeki insanlardan hayatındaki diğer çalışmalarından veya uykuya ayırdıkları zamandan daha değerliyse
- İnternet kullanımını azaltmaya çalıştıkları halde olmuyor bir süre sonra yine eski kullanım sürelerine geri dönüyorlarsa (Balcı ve Gülnar, 2009).

Sosyal medyada çok fazla zaman harcayan bireyler, sanal bir hoşgörüyü, sanal iletişime ve sanal soruna neden olabilecek bir şeyden hemen haberdar olma arzusuna sahiptirler. Kişiyi bu eylemlere zorlayan davranışlar sosyal medya bağımlılığı olarak açıklanabilir.

Araştırmanın Amacı

Bu çalışmanın amacı, ortaokul öğrencilerinin sosyal medya bağımlılık düzeylerini belirlemek ve öğrencilerin sosyal medya bağımlılık düzeylerini çeşitli demografik değişkenler açısından incelemektir. Bu amaçlara ulaşabilmek için aşağıdaki sorulara cevap aranmıştır.

1. Ortaokul öğrencilerinin sosyal medya bağımlılık düzeyleri nasıldır?
2. Ortaokul öğrencilerinin sosyal medya bağımlılık düzeyleri;
 - a. Cinsiyet,
 - b. Akıllı telefon sahipliği,
 - c. En sık kullanılan sosyal ağ sitesi,
 - d. Sosyal ağ sitesi üyelik süresi,değişkenlerine göre farklılaşmakta mıdır?
3. Ortaokul öğrencilerinin sosyal medya bağımlılığı, sosyal ağ sitesi arkadaş sayısı ve sosyal ağ sitesi kullanma sıklığı arasında bir ilişki var mıdır?

Yöntem

Araştırma Modeli

Bu çalışmada ortaokul öğrencilerinin internet bağımlılığı düzeylerini ortaya koyabilmek için genel tarama modeli kullanılmıştır. Genel tarama modeli, çok fazla katılımcının olduğu bir evrende, evren hakkında genel bir sonuç elde edebilmek amacı ile tüm evreni kapsayan bir çalışma ya da ondan alınacak daha küçük bir grup, örnek veya örneklem de yapılan araştırmalardır (Karasar, 1999).

Çalışma Grubu

Araştırmaya Türkiye'nin orta kesimindeki büyük bir ilde bulunan bir ortaokulda öğrenim gören 61'i kız 101'i de erkek olmak üzere toplam 162 ortaokul öğrencisi gönüllülük esasına göre katılmıştır. Çalışma grubu ile ilgili istatistikî bilgiler Tablo 1'de verilmiştir.

Tablo 1. Çalışma grubunun demografik özellikleri

Değişken	Seçenek	n	f (%)
Cinsiyet	Kız	61	62,3
	Erkek	101	37,7
Akıllı Telefon	Var	72	44,4
	Yok	90	55,6
En Sık Kullanılan Sosyal Ağ Sitesi	Facebook	69	42,6
	Instagram	52	32,1
	YouTube	41	25,3
Sosyal Ağ Sitesi Üyelik Süresi	0-1 yıl	75	46,3
	1-3 yıl	50	30,9
	3+ yıl	37	22,8

Tablo 1'de görüldüğü üzere çalışmaya katılan öğrencilerin 61'i kızlardan oluşurken 101'i erkeklerden oluşmaktadır. Öğrencilerin %55,6'sında (90 kişi) akıllı telefon yokken, %44,4'ünde akıllı telefon olduğu görülmektedir. Öğrencilerin en sık kullandıkları sosyal ağ sitesi sırasıyla, Facebook, Instagram ve YouTube şeklindedir. Öğrencilerin sosyal ağ sitelerine üyelik süresi sıralamasında ise öğrencilerin %46,3'ü 0-1 yıl arası, %30,9'u 1-3 yıl arası ve %22,8'i de 3 yıl ve daha fazla süredir sosyal ağ sitesine üye olduklarını belirtmişlerdir.

Veri Toplama Araçları

Araştırma verilerini toplamak için "Sosyal Medya Bağımlılığı Ölçeği-Öğrenci Formu (SMBÖ-ÖF)" kullanılmıştır.

Sosyal Medya Bağımlılığı Ölçeği-Öğrenci Formu (SMBÖ-ÖF)

Bu ölçek Şahin (2018) tarafından öğrencilerin sosyal medya bağımlılık düzeylerini belirlemek için geliştirilmiştir. Ölçek, 5'li Likert tipinde olup; (1) “Bana hiç uygun değil”, (2) “Bana uygun değil”, (3) “Kararsızım”, (4) “Bana uygun”, (5) “Bana çok uygun” aralığında puanlanmaktadır. Sosyal medya bağımlılığını incelemek için 29 tane maddeden oluşan ölçekte 1-5 arasındaki sorular sanal tolerans alt boyutunu, 6-14 arasındaki sorular sanal iletişim alt boyutunu, 15-23 arasındaki sorular sanal problem alt boyutunu ve 24-29 arasındaki sorular da sanal bilgilenme alt boyutunu oluşturmaktadır. Ölçeğin KMO katsayısı .96; Barlet anlamlılık değeri $\chi^2=12680.88$ ($p=.00$) düzeyinde anlamlı bulunmuştur. Ölçeğin geneli için iç tutarlılık katsayısı .93 olarak bulunurken; alt faktörler için ise, .81 ile .86 arasında değerler aldığı görülmektedir. Ayrıca ölçeğin test-tekrar test katsayısı .94 olarak bulunmuştur. Ölçekten alınabilecek en düşük toplam puan 29, en yüksek toplam puan 145'dir. Ölçekteki puanlamanın yüksek çıkması durumunda bireyin sosyal medya bağımlısı olduğu anlaşılmaktadır.

Verilerin Analizi ve Yorumlanması

Toplanan veriler SPSS 21.00 paket programı ile analiz edilmiştir. Analiz öncesinde verilerin normal dağılım gösterip göstermediği test edilmiştir. Bu amaçla ölçeklerden alınan toplam puanların dağılımları üzerinde çarpıklık ve basıklık değerleri incelenmiş ve hesaplama sonucunda çarpıklık ve basıklık katsayılarının -1,5 ile +1,5 sınırları içinde kaldığı görülmüştür. Çarpıklık ve basıklık katsayılarının -1,5 ile +1,5 sınırları içinde kalması, puanların normal dağılım sergilediğini göstermektedir (Tabachnick & Fidell, 2001). Bunun sonucunda ölçeklerden elde edilen veriler üzerinde parametrik testlerin kullanılmasına karar verilmiştir. Bu kapsamda toplanan verilerin analizinde betimsel istatistikler, korelasyon analizi, ikili gruplar arasındaki farkları belirlemek için bağımsız örneklem t-testi, ikiden fazla gruplar arasındaki farkları belirlemek için de ANOVA analizi kullanılmıştır.

Bulgular

Ortaokul Öğrencilerinin Sosyal Medya Bağımlılık Düzeyleri

Ortaokul öğrencilerinin sosyal medya bağımlılık düzeylerini belirlemek için sosyal medya bağımlılık ölçeğinin “sosyal tolerans”, “sanal iletişim”, “sanal problem” ve “sanal bilgilenme” alt boyutlarından ve ölçeğin toplamından aldıkları puanlar incelenmiştir. Analiz sonuçları Tablo 2’de verilmiştir.

Tablo 2. Ortaokul öğrencilerinin sosyal medya bağımlılık düzeyleri

Ölçek	Faktör	N	Min.	Max.	\bar{X}	SS
Sosyal Medya Bağımlılığı	Sosyal tolerans	162	1	5	1,87	,832
	Sanal iletişim	162	1	5	2,04	,801
	Sanal problem	162	1	5	1,71	,816
	Sanal bilgilenme	162	1	5	1,95	,846
Toplam Sosyal Medya Bağımlılığı		162	1	5	1,89	,734

Gerçekleştirilen analiz sonucunda elde edilen bulgular, ortaokul öğrencilerinin sosyal medya bağımlılığı ölçeğinin tüm alt boyutlarından (sosyal tolerans [$\bar{X}=1,87$], sanal iletişim [$\bar{X}=2,04$], sanal problem [$\bar{X}=1,71$] ve sanal bilgilenme [$\bar{X}=1,95$]) ve sosyal medya bağımlılığı ölçeğinin genelinden [$\bar{X}=1,89$] aldıkları puanların “hiç uygun değil” ve “uygun değil” aralığında olduğunu göstermektedir. Buna göre ortaokul öğrencilerinin genel olarak düşük düzeyde sosyal medya bağımlılığı sergiledikleri söylenebilir.

Ortaokul Öğrencilerinin Sosyal Medya Bağımlılık Düzeylerinin Cinsiyete Göre İncelenmesi

Ortaokul öğrencilerinin sosyal medya bağımlılıklarının cinsiyete göre farklılaşma durumları bağımsız örneklem t-testi ile incelenmiş olup analiz sonuçları Tablo 3’de verilmiştir.

Tablo 3. Sosyal medya bağımlılığının cinsiyet açısından analiz sonuçları

Ölçek	Faktör	Cinsiyet	N	\bar{X}	SS	t	p
Sosyal Medya Bağımlılığı	Sosyal tolerans	Kız	61	1,69	,766	2,193	,030
		Erkek	101	1,99	,855		
	Sanal iletişim	Kız	61	1,84	,727	2,507	,013
		Erkek	101	2,16	,824		
	Sanal problem	Kız	61	1,56	,747	1,988	,049
		Erkek	101	1,81	,844		
	Sanal bilgilendirme	Kız	61	1,88	,789	0,823	,412
		Erkek	101	2,01	,880		
Toplam Sosyal Medya Bağımlılığı	Kız	61	1,99	,674	2,140	,034	
	Erkek	101	1,73	,755			

Tablo 3'te verilen değerler incelendiğinde, ortaokul öğrencilerinin sosyal medya bağımlılığı ölçeğinin “sosyal tolerans ($t=2,193$; $p<0,05$)”, “sanal iletişim ($t=2,507$; $p<0,05$)” ve “sanal problem ($t=1,988$; $p<0,05$)” alt boyutlarından aldıkları puanlarda ve “toplam sosyal medya bağımlılığı ($t=2,140$; $p<0,05$)” puanlarında cinsiyete göre anlamlı bir farklılık vardır. Bu sonuçlara göre genel olarak erkek öğrencilerin sosyal medya bağımlılık düzeylerinin kız öğrencilere göre daha yüksek olduğu söylenebilir.

Ortaokul Öğrencilerinin Sosyal Medya Bağımlılık Düzeylerinin Akıllı Telefon Sahipliğine Göre İncelenmesi

Ortaokul öğrencilerinin sosyal medya bağımlılıklarının akıllı telefon sahipliğine göre farklılaşma durumları bağımsız örneklem t-testi ile incelenmiş olup analiz sonuçları Tablo 4'de verilmiştir.

Tablo 4. Sosyal medya bağımlılığının akıllı telefon sahipliği açısından analiz sonuçları

Ölçek	Faktör	Akıllı Telefon	N	\bar{X}	SS	t	p
Sosyal Medya Bağımlılığı	Sosyal tolerans	Var	72	2,10	,957	3,058	,003
		Yok	90	1,69	,670		
	Sanal iletişim	Var	72	2,17	,916	1,853	,066
		Yok	90	1,93	,683		
	Sanal problem	Var	72	1,95	,970	3,303	,001
		Yok	90	1,52	,608		
	Sanal bilgilendirme	Var	72	2,12	,964	2,220	,028
		Yok	90	1,81	,716		
Toplam Sosyal Medya Bağımlılığı	Var	72	2,08	,855	2,897	,004	
	Yok	90	1,74	,581			

Tablo 4'te verilen değerler incelendiğinde, ortaokul öğrencilerinin sosyal medya bağımlılığı ölçeğinin “sosyal tolerans ($t=3,058$; $p<0,05$)”, “sanal problem ($t=3,303$; $p<0,05$)” ve “sanal bilgilendirme ($t=2,220$; $p<0,05$)” alt boyutlarından aldıkları puanlarda ve “toplam sosyal medya bağımlılığı ($t=2,897$; $p<0,05$)” puanlarında akıllı telefon sahipliğine göre anlamlı bir farklılık vardır. Bu sonuçlara göre genel olarak akıllı telefonu olan öğrencilerin sosyal medya bağımlılık düzeylerinin akıllı telefonu olmayanlara göre daha yüksek olduğu söylenebilir.

Ortaokul Öğrencilerinin Sosyal Medya Bağımlılık Düzeylerinin En Sık Kullandıkları Sosyal Ağ Sitesine Göre İncelenmesi

Ortaokul öğrencilerinin sosyal medya bağımlılıklarının en sık kullandıkları sosyal ağ sitesine göre farklılaşma durumları tek yönlü varyans analizi (ANOVA) ile analiz edilmiştir. Analiz sonuçları Tablo 5'te verilmiştir.

Tablo 5. Sosyal medya bağımlılığının en sık kullanılan sosyal ağ sitesi açısından analiz sonuçları

Ölçek	En Sık Kullanılan Sosyal Ağ Sitesi	N	\bar{X}	SS	F	p	Fark (Scheffe)
Sosyal Medya Bağımlılığı	Sosyal tolerans	Facebook ^A	69	1,777	0,8503	,825	,440
		Instagram ^B	52	1,939	0,8619		
		Youtube ^C	41	1,956	0,7623		
	Sanal iletişim	Facebook ^A	69	1,995	0,8989	,243	,785
		Instagram ^B	52	2,041	0,8192		
		Youtube ^C	41	2,106	0,6620		
	Sanal problem	Facebook ^A	69	1,564	0,7585	2,060	,131
		Instagram ^B	52	1,814	0,8036		
		Youtube ^C	41	1,837	0,9000		
	Sanal bilgilenme	Facebook ^A	69	1,882	0,9390	,365	,695
		Instagram ^B	52	2,003	0,7896		
		Youtube ^C	41	1,988	0,7614		
Toplam Sosyal Medya Bağımlılığı	Facebook ^A	69	1,725	0,9217	4,933	,008	B>A
	Instagram ^B	52	2,270	1,0312			
	Youtube ^C	41	2,006	1,0854			

Tablo 5'te verilen değerler incelendiğinde, ortaokul öğrencilerinin toplam sosyal medya bağımlılığı puanlarına [$F_{(2,159)}=4,933$; $p<0,05$] bakıldığında en sık kullandıkları sosyal ağ sitesi açısından istatistiksel olarak anlamlı bir fark olduğu görülmektedir. Farkı oluşturan temel etkinin hangi değişkenden geldiğini belirlemek için Scheffe testi uygulanmıştır. Scheffe testi sonuçlarına göre, toplam sosyal medya bağımlılığı puanlarındaki farkın en sık kullandığı sosyal ağ sitesi Instagram olan öğrenciler ile Facebook olan öğrencilerden kaynaklandığı görülmektedir. Bu sonuca göre, sosyal ağ sitesi olarak en sık Instagram'ı kullanan öğrencilerin sosyal medya bağımlılıklarının Facebook'u kullanan öğrencilere göre daha yüksek olduğu söylenebilir.

Ortaokul Öğrencilerinin Sosyal Medya Bağımlılık Düzeylerinin Sosyal Ağ Sitesi Üyelik Süresine Göre İncelenmesi

Ortaokul öğrencilerinin sosyal medya bağımlılıklarının sosyal ağ sitesi üyelik süresine göre farklılaşma durumları tek yönlü varyans analizi (ANOVA) ile analiz edilmiştir. Analiz sonuçları Tablo 6'da verilmiştir.

Tablo 6. Sosyal medya bağımlılığının sosyal ağ sitesi üyelik süresi açısından analiz sonuçları

Ölçek	Sosyal Ağ Sitesi Üyelik Süresi	N	\bar{X}	SS	F	p	Fark (Scheffe)	
Sosyal Medya Bağımlılığı	Sosyal tolerans	0-1 yıl ^A	75	1,659	0,6887	6,382	,002	C>A
		1-3 yıl ^B	50	1,936	1,0161			
		3+ yıl ^C	37	2,227	0,6983			
	Sanal iletişim	0-1 yıl ^A	75	1,843	0,7483	5,477	,005	C>A
		1-3 yıl ^B	50	2,098	0,9167			
		3+ yıl ^C	37	2,351	0,6266			
	Sanal problem	0-1 yıl ^A	75	1,633	0,7920	,727	,485	
		1-3 yıl ^B	50	1,760	0,8767			
		3+ yıl ^C	37	1,814	0,7835			
	Sanal bilgilenme	0-1 yıl ^A	75	1,807	0,7856	5,353	,006	C>A
		1-3 yıl ^B	50	1,873	0,9145			
		3+ yıl ^C	37	2,333	0,7698			
Toplam Sosyal Medya Bağımlılığı	0-1 yıl ^A	75	1,800	1,0000	13,878	,000	C>A	
	1-3 yıl ^B	50	1,780	0,8640				
	3+ yıl ^C	37	2,730	0,9617				

Tablo 6 incelendiğinde, ortaokul öğrencilerinin sosyal medya bağımlılığı ölçeğinin sosyal tolerans [$F_{(2,159)}=6,382$; $p<0,05$], sanal iletişim [$F_{(2,159)}=5,477$; $p<0,05$] ve sanal bilgilenme [$F_{(2,159)}=5,353$; $p<0,05$] alt boyutlarından ve ölçeğin genelinden [$F_{(2,159)}=13,878$; $p<0,05$] aldıkları puanlarda sosyal ağ sitesi üyelik süresi

açısından anlamlı bir farklılık vardır. Farkı oluşturan temel etkinin hangi değişkenden geldiğini belirlemek için Scheffe testi uygulanmıştır. Scheffe testi sonuçlarına göre, sosyal medya bağımlılığının sosyal tolerans, sanal iletişim ve sanal bilgilendirme alt boyutlarındaki ve toplam sosyal medya bağımlılığı puanlarındaki farkın sosyal ağ sitesi üyelik süresi 0-1 yıl arasında olan öğrenciler ile 3 yıldan fazla olan öğrencilerden kaynaklandığı görülmektedir. Bu sonuca göre, 3 yıldan fazla süredir sosyal ağ sitesi üyesi olan öğrencilerin sosyal medya bağımlılıklarının 0-1 yıl arasında sosyal ağ sitesi üyesi olan öğrencilere göre daha yüksek olduğu söylenebilir.

Sosyal Medya Bağımlılığı, Sosyal Ağ Sitesi Arkadaş Sayısı ve Sosyal Ağ Sitesi Kullanma Sıklığı Arasındaki İlişkiler

Ortaokul öğrencilerin sosyal medya bağımlılıkları, sosyal ağ sitesi arkadaş sayıları ve sosyal ağ sitesi kullanma sıklıkları arasındaki ilişkiyi analiz edebilmek amacıyla Pearson Momentler Çarpım Korelasyonu kullanılmış olup analiz sonucu elde edilen değerler Tablo 7’de gösterilmiştir.

Tablo 7. Sosyal Medya Bağımlılığı, Sosyal Ağ Sitesi Arkadaş Sayısı ve Sosyal Ağ Sitesi Kullanma Sıklığı Arasındaki İlişkiler

Değişken	1	2	3	4	5	6	7
1. Sosyal tolerans	–						
2. Sanal iletişim	,799**	–					
3. Sanal problem	,769**	,799**	–				
4. Sanal bilgilendirme	,612**	,675**	,654**	–			
5. Toplam sosyal medya bağımlılığı	,878**	,932**	,922**	,813**	–		
6. Sosyal ağ sitesi arkadaş sayısı	,351**	,415**	,329**	,385**	,415**	–	
7. Sosyal ağ sitesi kullanma sıklığı	,222**	,236**	,335**	,272**	,305**	,100	–

** : Korelasyon 0.01 düzeyinde anlamlı (2-yönlü).

Tablo 7 incelendiğinde, araştırmanın değişkenlerinden sosyal ağ sitesi arkadaş sayısı ve sosyal ağ sitesi kullanma sıklığı arasında herhangi bir ilişki bulunmazken ($r=,100$; $p>0,05$); diğer bütün değişkenler arasında pozitif yönde ve anlamlı bir ilişki bulunmuştur. Bu sonuçlara göre, ortaokul öğrencilerinin sosyal ağ sitesi arkadaş sayısı ve sosyal ağ sitesi kullanma sıklığı arttıkça sosyal medya bağımlılıklarının da arttığı söylenebilir.

Tartışma ve Sonuç

İnternet hayatımızı kolaylaştırmayı sağlayan günümüzün en önemli teknolojik gelişmelerinden birisidir. İnternet bilinçli ve amacına uygun bir şekilde kullanıldığında hem zamandan tasarruf hem de zamanı verimli kullanma gibi çok fayda sağlamaktadır. Günümüzde özellikle çocuklar ve ergenler en başta öğrenme olmak üzere, boş zamanlarını en verimli şekilde değerlendirme ve sosyal etkinlikler geliştirme açısından internetle tamamen bağlı hareket etmektedir. Yalnız bu durum, yaş itibari ile küçük olmalarından dolayı internetin ve sosyal medyanın olumsuz etkilerine karşı yetişkinlere göre daha az duyarlılık göstermektedirler (Strasburger, Wilson ve Jordan, 2009). İnternet kullanımında, süreci ve zamanı yönetme konusunda kullanıcıların duyarlılıkları da çok önemlidir. Ortaokul öğrencileri ve ergenler başta olmak üzere interneti amacı dışında ve çok fazla kullanılması durumunda internet bağımlılığı gibi olumsuz sonuçlarda ortaya çıkmaktadır. İnternet bağımlılığı durumunda kullanıcıların sürekli internet kullanmak istemesi, bunu gerekli görmesi, internete bağlanmadığında ise internete bağlanacağı anı hayal ederek mutlu olmaya çalıştıkları görülmüştür (Çakır Balta ve Horzum, 2008).

Bu araştırma da ortaokul 5, 6, 7, 8.sınıf öğrencilerinin sosyal medya bağımlılık düzeylerinin incelenmesi ve sosyal medya bağımlılık düzeylerinin akıllı telefon sahipliği, en sık kullanılan sosyal ağ sitesi ve sosyal ağ sitesi üyelik süresi değişkenlerine göre farklılaşp farklılaşmadığının belirlenmesi amaçlanmıştır. Bunun yanında araştırma kapsamında ortaokul öğrencilerinin sosyal medya bağımlılığı, sosyal ağ sitesi arkadaş sayısı ve sosyal ağ sitesi kullanma sıklığı arasındaki ilişkiler analiz edilmiştir.

Araştırma sonucunda elde edilen bulgulara göre, ortaokul öğrencilerinin sosyal medya bağımlılık ölçeğinde verdikleri yanıtlar genel olarak “hiç uygun değil” ve “uygun değil” şeklinde çıkmıştır. Bu sonuçlar doğrultusunda ortaokul öğrencilerinin geneli düşük düzeyde sosyal medya bağımlısı oldukları görülmüştür. Literatür incelendiğinde ise bu konu ile ilgili araştırmaların genellikle lise ve üniversite düzeyinde yapıldığı görülmekte ve lise düzeyinde sosyal medya bağımlılık düzeyi orta seviyelerde görülürken üniversite öğrencilerinde bu seviye yüksek düzeyde görülmektedir (Deniz ve Gürültü, 2018). Burada teknolojik cihazlara ulaşma imkânı ve sosyal çevrenin de etkisinin büyük olduğu söylenebilir.

Cinsiyete göre sosyal medya bağımlılık puanları değerlendirildiğinde, erkek öğrencilerin kız öğrencilere göre anlamlı düzeyde fazla puanı olduğu tespit edilmiştir. Bu sonuçlara göre genel olarak erkek öğrencilerin sosyal medya bağımlılık düzeylerinin kız öğrencilere göre daha yüksek olduğu orta çıkmıştır.

Literatür incelendiğinde sosyal medya bağımlılığının cinsiyete göre farklılaşma durumlarının araştırıldığı çalışmalarda bir bölünmenin olduğu görülmektedir. Yapılan bazı çalışmalarda kız öğrencilerin sosyal medya bağımlılığının erkeklere göre daha yüksek olduğu tespit edilirken (Ergenç, 2011; Hazar, 2011; Balcı ve Gölcü, 2013; Tutgun Ünal, 2015) bazılarında ise erkek öğrencilerin sosyal medya bağımlılıklarının kız öğrencilere göre daha yüksek olduğu tespit edilmiştir (Seferoğlu ve Yıldız, 2013; Tanrıverdi ve Sağır, 2014; Yılmazsoy ve Kahraman, 2017). Bunun yanında sosyal medya bağımlılığı açısından kız ve erkek öğrenciler arasında bir farklılığın olmadığı sonucuna ulaşan çalışmalar da bulunmaktadır (Deniz ve Gürültü, 2018). Literatürde çıkan bu farklı sonuçların araştırmanın yapıldığı hedef kitlenin farklı özelliklerde olması, farklı coğrafi bölgelerde yaşamaları, sosyokültürel ve ekonomik durumlarındaki farklılıklar sonucunda ortaya çıkmış olabileceği söylenebilir.

Akıllı telefon sahipliğine göre sosyal medya bağımlılığının genel olarak akıllı telefona sahip ortaokul öğrencilerinin sosyal medya bağımlılık düzeylerinin akıllı telefonu olmaya öğrencilere göre daha yüksek olduğu görülmektedir. Bunun nedeni ise her an sosyal ağ sitelerine ebeveynlerden izinli ya da izinsiz istenildiği zaman çevrim içi olabilmeye özgürlüğünün olmasıdır. Ortaokul öğrencilerinin sosyal medya bağımlılık düzeylerinin en sık kullandıkları sosyal ağ sitelerine göre farklılaşma durumlarında da anlamlı bir fark olduğu görülmektedir. Toplam sosyal medya bağımlılığı puanlarındaki farkın en sık kullandığı sosyal ağ sitesi Instagram olan öğrenciler ile Facebook olan öğrencilerden kaynaklandığı görülmektedir. Bu sonuca göre, sosyal ağ sitesi olarak en sık Instagram'ı kullanan öğrencilerin sosyal medya bağımlılıklarının Facebook'u kullanan öğrencilere göre daha yüksek olduğu söylenebilir. Ortaokul öğrencilerinin sosyal medya bağımlılık düzeylerinin sosyal ağ sitesi üyelik süresine göre incelenmesi sonucunda ise uzun yıllar üyeliği olan öğrencilerin diğerlerine oranla daha fazla sosyal medya bağımlısı oldukları tespit edilmiştir. Akyazı ve Tutgun Ünal (2013) ve Tutgun Ünal (2015)'in üniversite öğrencileri ile ve Deniz ve Gürültü (2018)'nin de lise öğrencileri ile yürüttükleri çalışmaların sonucunda da sosyal ağ sitelerine uzun yıllar üyeliği olan öğrencilerin diğerlerine göre sosyal medya bağımlılıklarının daha yüksek olduğu ortaya çıkmıştır. Son olarak, araştırmada sosyal medya bağımlılığı ile sosyal ağ sitesi arkadaş sayısı ve sosyal ağ sitesi kullanma sıklığı arasında pozitif yönde ve anlamlı bir ilişki bulunmuştu. Bu sonuçlara göre, ortaokul öğrencilerinin sosyal ağ sitesi arkadaş sayısı ve sosyal ağ sitesi kullanma sıklığı arttıkça sosyal medya bağımlılıklarının da arttığı söylenebilir. Nitekim bazı çalışmalarda öğrencilerin günlük olarak sosyal medyaya ayırdıkları vaktin artması, onların sosyal medya bağımlılığı üzerinde belirleyici unsurlardan biri olarak görülmektedir (Aktan, 2018; Balcı ve Gölcü, 2013; Demir ve Kumcağız, 2019; Savcı, Ercengiz ve Aysan, 2018). Sonuç olarak, sosyal medya kullanımının bağımlılık boyutuna ulaşmasının nedenlerin birisinin de aşırı kullanım olduğu ifade edilebilir.

Kaynakça

- Aktan, E. (2018). Üniversite öğrencilerinin sosyal medya bağımlılık düzeylerinin çeşitli değişkenlere göre incelenmesi. *Erciyes İletişim Dergisi*, 5(4), 405-421.
- Balcı, Ş., & Gölcü, A. (2013). Facebook addiction among university students in Turkey: Selçuk University example. *Türkiyat Araştırmaları Dergisi*, 34, 255-278.
- Balcı, Ş., & Gülнар, B. (2009). Üniversite öğrencileri arasında internet bağımlılığı ve internet bağımlılarının profili. *Selçuk Üniversitesi İletişim Fakültesi Akademik Dergisi*, 6(1), 5-22.
- Bayraktutan, F. (2005). *Aile içi ilişkiler açısından internet kullanımı* (Yayımlanmamış Yüksek Lisans Tezi). İstanbul: İstanbul Üniversitesi.
- Canberk, G., & Sağıroğlu, Ş. (2007). Çocuklar ve gençlerin bilgisayar ve internet güvenliği. *Politeknik Dergisi*, 10(1), 33-39.
- Caplan, S. E. (2005). A social skill account of problematic internet use. *The Journal of Communication*, 55(4), 721-736.
- Chou, C., Condrón, L., & Belland, J. C. (2005). A review of the research on internet addiction. *Educational Psychology Review*, 17(4), 363-388.
- Çakır Balta, Ö., & Horzum, M. B. (2008). İnternet bağımlılığı testi. *Eğitim Bilimleri ve Uygulama Dergisi*, 7(13), 99-121.
- Demir, Y., & Kumcağız, H. (2019). Üniversite öğrencilerinin sosyal medya bağımlılığının farklı değişkenler açısından incelenmesi. *Türk Psikolojik Danışma ve Rehberlik Dergisi*, 9(52), 23-42.
- Deniz, L., & Gürültü, E. (2018). Lise öğrencilerinin sosyal medya bağımlılıkları. *Kastamonu Eğitim Dergisi*, 26(2), 355-367.
- DiMaggio, P., Hargittai, E., Neuman, W. R., & Robinson, J. P. (2001). Social implications of the internet. *Annual Review of Sociology*, 27, 307-336.
- Egger, O., & Rauterberg, M. (1996). *Internet behavior and addiction*. Zurich: Swiss Federal Institute of Technology.

- Ergenç, A. (2011). *Web 2.0 ve sanal sosyalleşme: Facebook örneği* (Yayımlanmamış Yüksek Lisans Tezi). İstanbul: Maltepe Üniversitesi.
- Gonzalez, N. A. (2002). *Internet addiction disorder and its relation to impulse control* (Unpublished Doctoral Dissertation). Kingsville, TX: Texas A & M University-Kingsville.
- Griffiths, M. D. (1999). Internet addiction: Factor fiction? *The Psychologist*, 12(5), 246-250.
- Hazar, M. (2011). Sosyal medya bağımlılığı-bir alan çalışması. *İletişim Kuram ve Araştırma Dergisi*, 32(1), 151-176.
- Irwansyah, M. A. (2005). *Internet uses, gratifications, addiction, and loneliness among international students* (Unpublished Master's Thesis). Honolulu, HI: University of Hawaii.
- Karasar, N. (1999). *Bilimsel araştırma yöntemi*. Ankara: Nobel Yayınevi.
- Kim, S., & Kim, R. (2002). A study of internet addiction: Status, causes, and remedies. *Journal of Korean Home Economics Association English Edition*, 3(1), 1-19.
- Köroğlu, G., Öztürk, Ö., Tellioglu, N., Genç, Y., Mırsal, H., & Beyazyürek, M. (2006). Problemlı internet kullanımıyla başvuran iki uçlu bir hasta nedeniyle psikiyatrik ek tanı tartışması: Olgu sunumu. *Bağımlılık Dergisi*, 7(3), 150-154.
- Murali, V., & George, S. (2007). Lost online: An overview of internet addiction. *Advances in Psychiatric Treatment*, 13(1), 24-30.
- Savcı, M., Ercengiz, M., & Aysan, F. (2018). Turkish adaptation of the social media disorder scale in adolescents. *Archives of Neuropsychiatry*, 55(3), 248-255.
- Seferoğlu, S. S., & Yıldız, H. (2013). Dijital çağın çocukları: İlköğretim öğrencilerinin Facebook kullanımları ve internet bağımlılıkları üzerine bir araştırma. *İletişim ve Diplomasi*, 2, 31-48.
- Strasburger, V. C., Wilson, B. J., & Jordan, A. B. (2009). *Children, adolescents, and the media* (2nd ed.). Thousand Oaks, CA: Sage Publishing.
- Şahin, C. (2018). Social media addiction scale-student form: The reliability and validity study. *The Turkish Online Journal of Educational Technology*, 17(1), 169-182.
- Tabachnick, B. G., & Fidell, L. S. (2001). *Using multivariate statistics* (Fourth Edition). Boston: Allyn and Bacon.
- Tanrıverdi, H., & Sağır, S. (2014). Lise öğrencilerinin sosyal ağ kullanım amaçlarının ve sosyal ağları benimseme düzeylerinin öğrenci başarısına etkisi. *Adyaman Üniversitesi Sosyal Bilimler Enstitüsü Dergisi*, 7(18), 776-821.
- Tutgun Ünal, A. (2015). *Sosyal medya bağımlılığı: Üniversite öğrencileri üzerine bir araştırma* (Yayımlanmamış Doktora Tezi). İstanbul: Marmara Üniversitesi.
- Yılmazsoy, B., & Kahraman, M. (2017). Üniversite öğrencilerinin sosyal medya bağımlılığı ile sosyal medyayı eğitsel amaçlı kullanımları arasındaki ilişkinin incelenmesi: Facebook örneği. *Journal of Instructional Technologies & Teacher Education*, 6(1), 9-20.
- Young, K. S., & Rodgers, R. (1998). The relationship between depression and internet addiction. *Cyberpsychology & Behavior*, 1(1), 25-28.
- Yüksel, G., & Baytemir, K. (2010). İlköğretim öğrencilerinin internet kullanım amaçları ile algıladıkları sosyal destek düzeylerinin incelenmesi. *Türk Eğitim Bilimleri Dergisi*, 8(1), 1-20.

Virtualization in Social Studies Education

Erol KOCOGLU
İnönü University

Abstract:The needs shaped by the concepts of change and time from the existence of mankind to the present day can be said to be met by the authorities in different ways in terms of space concept in the world. The nature of the methods or equipment used to meet these needs affects the speed of the response to the need and the level of satisfaction of the individual or community to be met. As an individual or society, the most important factor that influences our needs from past to present is the process of adapting to the requirements arising as a result of technology and technology, which are the key to change. These technological tools differ according to their intended use and categories. The prominent category in this study is virtualization technologies and their use in social studies education. In this study where qualitative research method is used, the opinions of the field experts who form the working group will be submitted to the content analysis and presented as graphs.

Keywords: Virtualization, Social studies, Workspace

Sosyal Bilgiler Eğitiminde Sanallaşma

Özet:İnsanoğlunun varlığından günümüze kadar değişim ve zaman kavramlarının şekillendirdiği ihtiyaçların, otoriteler tarafından dünyadaki mekan kavramı açısından farklı şekillerde karşılandığı söylenebilir. Bu ihtiyaçları karşılamak için kullanılan yöntem veya ekipmanın niteliği, ihtiyaca cevap verme hızını ve karşılanacak birey veya topluluğun memnuniyet düzeyini etkiler. Birey veya toplum olarak, geçmişten günümüze ihtiyaçlarımızı etkileyen en önemli faktör, değişimin anahtarı olan teknoloji ve teknolojinin bir sonucu olarak ortaya çıkan gereksinimlere uyum sağlama sürecidir. Bu teknolojik araçlar, kullanım amaçlarına ve kategorilerine göre farklılık göstermektedir. Bu çalışmada öne çıkan kategori sanallaştırma teknolojileri ve bunların sosyal bilgiler eğitiminde kullanımlarıdır. Nitel araştırma yönteminin kullanıldığı bu çalışmada, çalışma grubunu oluşturan saha uzmanlarının görüşleri içerik analizine sunulacak ve grafikler halinde sunulacaktır.

Anahtar Kelimeler: Sanallaşma, Sosyal bilgiler, Çalışma alanı

Giriş

Sanal kelimesi İngilizce virtual kelimesinden gelmektedir. Virtual kelimesinin anlam karşılığını Hof (1997'den akt. Keskin ve Küçükali, 2017) gerçekte var olmayan fakat sanki varmış gibi duyulan hissedilen olarak tanımlamıştır (Çavuşoğlu, 2004; Keskin ve Küçükali, 2017). Licliler ilk defa 1952 yılında bilgisayarlarda “ olmadığı halde varmış gibi kullanılan sanal bellek kavramı” ile sanallığı gündeme getirmiştir (Kartal, 2002; Keskin ve Küçükali, 2017). Sanal ortam yani siberuzay, dünyadaki tüm sınırları ortadan kaldırmış, globalleşmeyi hızlandırmış yapılan işlerde zaman kullanımını azaltmış, haberleşme ve ticari işler yirmi dört saatte yapılabilir hale gelmiştir (Çavuşoğlu, 2004). Böylelikle internet kullanımı yaşamın vazgeçilmez bir parçası ve ihtiyacı haline gelmiştir. İnternetin yaşamın vazgeçilmez bir ögesi haline gelmesi yaşam sürecinde bireyi ve toplumu sanallaştırma etkinliklere iten etkenlerin başında geldiği söylenebilir. Sanallaşma ve buna bağlı olarak oluşan sanallaştırma çalışmaları bilişim toplumuna geçişi hızlandırmıştır (Denizci, 2009). Böylelikle internet dünyasına dair kavramlar düşünölmeye ve bir süre sonra da geliştirilmeye başlanmıştır. Zamanla, internet ve teknolojik gelişmeler birbirine paralel bir hızda ilerlemiştir. İnternet, dünya çapında milyonlarca bilgisayarı birbirine bağlayan bir sistem olarak tanımlanmaya başlanmıştır (Geray, 2002; Keskin ve Küçükali, 2017). İnternet kullanımında zaman ve mekân kavramları da önem taşımaktadır. Kullanıcı içinde bulunduğu zamandan ve mekândan bağımsızlaşma duygusunu sanal ortamda yaşayabilmektedir. Bunu bazen zaman kavramı olmayan bir oyun ile bazen de kendisini olduğu değil de olmak istediği gibi gösterebileceği ve denetleme/doğrulama mekanizması bulunmayan sanal sohbet ortamlarında sağlayabilmektedir. Sanal Gerçeklik, katılımcılarına gerçekmiş hissi veren, bilgisayarlar tarafından yaratılan dinamik bir ortamla karşılıklı iletişim olanağı tanıyan, bir benzetim modelidir (Bayraktar ve Kaleli, 2007; Keskin ve Küçükali, 2017). Sanallaştırma; IBM'in 1960'lı yıllarda geliştirmeye başladığı bir teknolojidir (Denning, 1981'den akt. Gürol ve Yavuzalp, 2011). Bu teknolojinin temelinde fiziksel sistemlerin sanal kopyalarının oluşturulması yatar. Sanallaştırma sayesinde işlemci, bellek, sabit disk ve ağ adaptörleri gibi mevcut fiziksel kaynaklar mantıksal bölümlere ayrılarak, her mantıksal bölümün farklı bir bilgisayar gibi davranması sağlanabilir (Nanda and Chiueh, 2005'den akt. Gürol ve Yavuzalp, 2011). Sanallaştırma, bilişim kaynaklarının (işlemci, depolama, ağ, bellek, platform,

sunucu, masaüstü, uygulama vb.) gerçekte var olan kaynağın değil de, gerçek kaynağa dayandırılarak tanımlanmış olan soyut halinin, kullanıcılara sunulması olarak tanımlanabilir. Böylece gerçek kaynak, göreceli olarak daha az kapasiteli çok sayıda sanal kaynak olarak kullanılabilir (TBD Kamu-BİB, 2010; Gürol ve Yavuzalp, 2011).

Araştırmanın Amacı

Bu çalışmanın temel amacı, Sosyal bilgiler öğretmenlerinin sosyal bilgiler dersindeki sanallaşma etkinliklerine ilişkin görüşlerini belirlemektir. Bu genel amaç çerçevesinde aşağıdaki sorulara cevap aranmıştır.

- ✓ Sanallaşma kavramının sizde uyandırdığı imgesel algılar nelerdir?
- ✓ Sosyal bilgiler eğitiminde sanallaşmaya yönelik etkinlikler yeterli düzeyde hazırlanıp uygulandığını düşünüyor musunuz, neden?
- ✓ Eğitimdeki sanallaşma faaliyetlerinin sosyal bilgiler eğitimine yansımaları sizce nelerdir?

Yöntem

Araştırmanın Modeli

Yapılan çalışma nitel araştırma yöntemi temele alınarak hazırlanmış olup durum çalışması modeline dayalı olarak hazırlanmıştır. Bu model, var olan bir sürece ilişkin elde edilen bulgular doğrultusunda verilerin analiz edilip yorumlanmasına dayanır.

Çalışma Grubu

Yapılan çalışmada çalışma grubunu Malatya İl Milli Eğitim Müdürlüğüne bağlı çeşitli ortaokullarda görev yapan 20 sosyal bilgiler öğretmeni oluşturmaktadır.

Veri Toplama Aracı

Araştırmada, sosyal bilgiler eğitimindeki sanallaşma faaliyetlerine ilişkin verileri elde etmek amacıyla araştırmacı tarafından geliştirilen yarı yapılandırılmış görüşme formu kullanılmıştır.

Verilerin Analizi

Yarı yapılandırılmış görüşme formu aracılığıyla elde edilen verilerin analizinde nitel araştırma yöntemi tekniklerinden biri olan içerik analizi tekniği kullanılmıştır. Veriler ana tema altında alt temalar şeklinde oluşturulup tablolar içinde gruplandırılarak verilmiştir.

Bulgular

Sanallaşmaya İlişkin Metaforik Algılara Yönelik Durum

Araştırmada yarı yapılandırılmış görüşme formunda yer alan “*Sanallaşma kavramının sizde uyandırdığı imgesel algılar nelerdir?*” şeklindeki soruya çalışma grubu üyelerinin vermiş oldukları yanıtlar içerik analizine tabi tutularak gruplandırılıp alt temalar şeklinde tablo 1’de gösterilmiştir. Tabloya bakıldığında sosyal bilgiler öğretmenlerinin konuya ilişkin farklı algılara sahip oldukları gözlemlenmektedir. Öğretmenlerin farklı algıya sahip olmaları, onların çalışma koşulları, yaşam standartları, teknolojiden yararlanma düzeyleri vb. etkili olduğu söylenebilir.

Tablo 1. Çalışma grubu üyelerinin sanallaşmaya ilişkin imgesel algıları

1.Tema: Sanallaşmaya İlişkin İmgesel Algılar		f
Alt Temalar		
G.1.	Teknolojik Materyaller (tablet, bilgisayar, projeksiyon, akıllı tahta)	12
G.2.	Bilgi erişim ağı	4
G.3.	Somutlaştırma ve zamana uyum	4
Toplam		20

Sosyal Bilgiler Eğitiminde Sanallaşma Etkinliklerinin Yeterlilik Durumu

Araştırma çalışma grubu üyelerine sorulan “*Sosyal bilgiler eğitiminde sanallaşmaya yönelik etkinlikler yeterli düzeyde hazırlanıp uygulandığını düşünüyor musunuz, neden?*” şeklindeki soruya çalışma grubunu oluşturan sosyal bilgiler öğretmenlerinin yetersiz düzeyde yaklaştıklarını tablo 2’de elde edilen verilerden anlıyoruz. Çalışma grubunu oluşturan sosyal bilgiler öğretmenlerinin negatif bakış açısını ortaya çıkaran birçok faktörün olduğunu söylemek mümkündür. Çalışma grubu üyeleri bu faktörleri tablo 2’de, alt temalar şeklinde gerekçelendirerek ifade ettikleri görülmektedir.

Tablo 2. Çalışma grubunun sosyal bilgiler eğitiminde sanallaşma etkinliklerinin yeterlilik durumuna ilişkin algıları

2.Tema: Sosyal bilgiler eğitiminde sanallaşma etkinliklerinin yeterlilik düzeyleri		f
Alt Temalar		
Evet	G.1.Eba erişim ağının kullanımı	4
Hayır	G.2.Öğretmenlerin yetersizlikleri	8
	G.3.Öğrenme ortamındaki koşul yetersizlikleri	8
Toplam		20

Sanallaşma Faaliyetlerinin Sosyal Bilgiler Eğitimine Yansıma Durumu

Eğitim-öğretim sürecindeki sanallaşma faaliyetlerinin sosyal bilgiler dersine yansımalarını tespit etmek amacıyla araştırmada çalışma grubu üyelerine “*Eğitimdeki sanallaşma faaliyetlerinin sosyal bilgiler eğitimine yansımaları sizce nelerdir?*” şeklinde soru yöneltilmiştir. Çalışma grubu üyeleri soruya vermiş oldukları tablo 3’deki yanıtları vermişlerdir. Çalışma grubu üyelerinin vermiş oldukları yanıtlar incelendiğinde sosyal bilgiler öğretmenlerinin konuya ilişkin çeşitli algılara sahip oldukları söylenebilir.

Tablo 3. Çalışma grubunun sosyal bilgiler eğitiminde sanallaşmanın yansımalarına ilişkin algıları

3.Tema: Sosyal bilgiler eğitiminde sanallaşmanın yansımaları		f
Alt Temalar		
G.1.Teknolojik oyunlarla öğretim		8
G.2.Akıllı tahta kullanımına dayalı etkinlikler		8
G.3.Sanal uygulama içerikli karikatürler, videolar vb.		4
Toplam		20

Sonuç ve Öneriler

- Araştırmada elde edilen bulgulardan hareketle şu sonuçlar elde edilmiştir:
- ✓ Sosyal bilgiler öğretmenlerinin sanallaşma algılarının farklı olduğu,
 - ✓ Sosyal bilgiler derslerinde sanallaşma etkinliklerinin yeterli düzeyde uygulanmadığı,
 - ✓ Sanallaşmanın sosyal bilgiler dersleri öğretimine yansımalarının öğrenme ortamındaki yapılan birçok etkinliğe dayalı olarak gerçekleştiği,
 - ✓ Sanallaşma faaliyetlerinin sosyal bilgiler derslerinde yeterli düzeyde kullanılmamasının sebeplerinden birinin öğretmenlerin konudaki yetersizlikleri olduğu söylenebilir.
Bu sonuçlardan hareketle;
 - ✓ Eğitim kurumlarımızda sanallaşmaya yönelik eğitimler öğretmenlerimize verilmelidir.
 - ✓ Sosyal bilgiler eğitimi dersleri gibi soyut içeriğin fazla olduğu derslerde sanallaşma etkinliklerine fazlasıyla yer verip ilgili konunun öğrenciler tarafından daha iyi anlaşılıp somutlaştırılmasını sağlamak gerekir.
 - ✓ Küreselleşen dünyada öğrenme ortamlarında teknolojik alt yapıdan yararlanmanın bir zorunluluk olduğu öğretmenlerimize hatırlatılmalı ve gerekli tedbirler alınmalıdır.

Kaynakça

- Keskin, K. ve Küçükali, U.F.(2017). Sanallaşmanın Toplum Hayatına Etkileri, *İnsan ve Toplum Bilimleri Araştırmaları Dergisi*, 6(1), 396-418.
- Çavuşoğlu, M. (2004). Sanal Organizasyonlar Ve Elektronik Ticaret. *Marmara Üniversitesi, İktisadi Ve İdari Bilimler Fakültesi Dergisi*, 19(1), 317 – 334.

- Kartal, C. (2002). İnternet Ortamında Pazarlama: Elektronik Ticarete İlk Adım. *Ankara*. Gazi Kitabevi.
- Denizci, Ö. M. (2009). Bilişim Toplumu Bağlamında İnternet Olgusu ve Sosyopsikolojik Etkileri. *Marmara İletişim Dergisi*, 15, 47-63.
- Geray, H. (2002). *İletişim ve Teknoloji*, Ütopya Yayınları, Ankara.
- Bayraktar, E. ve Kaleli, F. (2007). Sanal Gerçeklik ve Uygulama Alanları. *Akademik Bilişim Dergisi*.
- Denning, P. J. (1981). Performance Modeling: Experimental Computer Science at its Best. Communications of the ACM, <http://cs.gmu.edu/cne/pjd/PUBS/ecs.pdf>.
- Gürol, M. ve Yavuzalp, N.(2011). Okullarda ve Eğitim Kurumlarında Sanallaştırma Teknolojileri, *5th International Computer & Instructional Technologies Symposium*, 22-24 September 2011, Fırat University, ELAZIĞ- TURKEY.
- Nanda, S. and Chiueh, T.(2005). A Survey on Virtualization Technologies. Experimental Computer Systems Lab Department of Computer Science, State University of New York. doi=10.1.1.74.371.
- TBD Kamu-BİB. (2010). Sanallaştırma. Kamu Bilişim Platformu XII, 1.Çalışma Grubu Raporu. http://www.tbd.org.tr/usr_img/cd/kamubib12/raporlarPDF/RP1-2010.pdf.

The Role of Social Studies Course in Creating a Digital Self

Erol KOCOGLU
İnönü University

Abstract: Human beings have been developing their communication skills since stepping on the stage of history. First of all, communication skills have been transformed by technological developments (printing) that convey speech, writing and experiences to future generations. In the following period, communication skills have shifted to a new dimension with the internet that transforms information into digital codes. Digital communication, interaction and transformation are widespread nowadays. The individual has a digital copy of the data for his / her general and private life. This copy is called the digital self. In this study, the effect of social studies lessons on the development of digital self will be determined according to the perceptions of social studies teachers. Random and criterion sampling techniques were used to determine the study group. Qualitative research method will be used in the study and content and descriptive analysis techniques will be used in the analysis of data. The data obtained in the study will be presented as tables and quotations will be made directly from the opinions. The data obtained as a result of the study will be presented as sub-themes and these themes will be discussed by the researcher with the help of literature and suggestions will be presented.

Keywords: Digitalization, Digital self, Social studies

Dijital Benlik Oluşturmada Sosyal Bilgiler Dersinin Rolü

Özet: İnsanlar, tarih sahnesine adım attığından beri iletişim becerilerini geliştiriyorlar. Her şeyden önce, iletişim becerileri konuşma, yazma ve deneyimleri gelecek nesillere aktaran teknolojik gelişmeler (baskı) ile değiştirildi. İlerleyen dönemde, internet ile bilgiyi dijital kodlara dönüştüren iletişim becerileri yeni bir boyuta geçti. Dijital iletişim, etkileşim ve dönüşüm günümüzde yaygın. Birey, genel ve özel hayatı için verinin dijital bir kopyasına sahiptir. Bu kopyaya dijital benlik denir. Bu çalışmada sosyal bilgiler derslerinin dijital benliğin gelişimi üzerindeki etkisi sosyal bilgiler öğretmenlerinin algılarına göre belirlenecektir. Çalışma grubunu belirlemek için rastgele ve ölçüt örnekleme teknikleri kullanılmıştır. Araştırmada nitel araştırma yöntemi kullanılacak, verilerin analizinde içerik ve betimsel analiz teknikleri kullanılacaktır. Araştırmada elde edilen veriler tablolar halinde sunulacak ve alıntılar doğrudan görüşlerden yapılacaktır. Çalışma sonucunda elde edilen veriler alt temalar olarak sunulacak ve bu temalar araştırmacı tarafından literatür yardımı ile tartışılacak ve öneriler sunulacaktır.

Anahtar Kelimeler: Dijitalleşme, Dijital benlik, Sosyal bilgiler

Giriş

Benlik (self), aslında insan zihninin sosyal tecrübelerle şekillenen ve potansiyel haldeki yapısal bütünlüğüdür. Kimlik ise, sosyal olarak şekillenmiş bu potansiyelin iradî bir kararlılıkla dışa yansıyan halidir. Fizikî çevre, sağlık şartları, biyolojik miras gibi diğer faktörlerin yanı sıra, tüm sosyal faktörler, benliğin oluşumuna katılırlar (Kurtkan Bilgiseven 1982:151).

Benlik topluma göre değişen bir olgudur ve kişinin gelişimini etkiler. Örneğin Japonya’da bir anne, iki yaşındaki benmerkezci bir çocukla yüzleşme eğilimi göstermez. Bunun yerine, çocuğuna “tahammül ederek” davranışının kendisine üzüntü ve sıkıntı verdiğini belirtir (Çakmak, 2017). Bu şekilde, çocuk daha çok küçük yaştan itibaren davranışlarının diğer insanlar açısından sosyal ve duygusal sonuçları olduğunu anlamaya yönlendirilir. Sebep olduğu sıkıntıdan dolayı sorumluluk ve suçluluk hissetmesi sağlanır; böylece sıkıntıya neden olmamanın ve suçluluk hissetmek zorunda kalmamanın bir yolu olarak kendini kontrol etmeyi öğrenir. Bu mesajlar çocukluk dönemi boyunca devam eder ve yetişkin davranışı üzerinde güçlü etkiler bırakır (Hayes, 2011; Çakmak, 2017).

Yeni teknolojilerin hızla gelişmesi internetin toplumsal yapı içerisinde olmazsa olmazlar arasına girmesi ve internet tabanlı sosyal ağların yoğun kullanımı günümüzün üzerinde tartışılan konuları arasına girmiştir. Dijital ortamda veri aktarımının olanaklı bir hal almasıyla birlikte görsel veri paylaşımı artmıştır (Akmeşe ve Deniz, 2017). Bu veri paylaşımı bireyin kimlik paylaşımını teknolojik ortamda sergilemesini beraberinde getirmiştir. Bu durum dijital kimlik ya da benlik oluşturmada, bireyin kendi benliğini oluştururken başkalarının görmek istediği benliği yarattığına işaret eder (İşman, Buluş ve Yüzüncüyıl, 2016). Öğrenme ortamlarında dijital benlik

oluşumunda birçok disiplin ve çalışma alanının etkili olduğu söylenebilir. Bu çalışma alanlarından biri de sosyal bilgiler eğitimidir. Bu çalışmada da bu etki düzeyi belirlenmeye çalışılmıştır.

Araştırmanın Amacı

Bu çalışmanın temel amacı, sosyal bilgiler öğretmenlerinin görüşleri doğrultusunda sosyal bilgiler dersinin dijital benlik oluşumu üzerindeki etkilerini belirlemektir. Bu genel amaç çerçevesinde aşağıdaki sorulara cevap aranmıştır.

- ✓ Dijital benlik kavramının sizde uyandırdığı imgesel algılar nelerdir?
- ✓ Sosyal bilgiler eğitimi dersinde yer alan hangi beceriler dijital benlik oluşumu üzerinde sizce daha çok etkilidir?
- ✓ Sosyal Bilgiler Eğitimdeki sanallaşma faaliyetlerinin dijital kimlik oluşumu üzerinde etkili olduğunu düşünüyor musunuz, neden?

Yöntem

Araştırmanın Modeli

Yapılan çalışma nitel araştırma yöntemi temele alınarak hazırlanmış olup durum çalışması modeline dayalı olarak hazırlanmıştır. Bu model, var olan bir sürece ilişkin elde edilen bulgular doğrultusunda verilerin analiz edilip yorumlanmasına dayanır.

Çalışma Grubu

Yapılan çalışmada çalışma grubunu Malatya il milli eğitim müdürlüğüne bağlı çeşitli ortaokullarda görev yapan 20 sosyal bilgiler öğretmeni oluşturmaktadır.

Veri Toplama Aracı

Araştırmada, sosyal bilgiler eğitimindeki sanallaşma faaliyetlerine ilişkin verileri elde etmek amacıyla araştırmacı tarafından geliştirilen yarı yapılandırılmış görüşme formu kullanılmıştır.

Verilerin Analizi

Yarı yapılandırılmış görüşme formu aracılığıyla elde edilen verilerin analizinde nitel araştırma yöntemi tekniklerinden biri olan içerik analizi tekniği kullanılmıştır. Veriler ana tema altında alt temalar şeklinde oluşturulup tablolar içinde gruplandırılarak verilmiştir.

Bulgular

Dijital Benlik Oluşumuna İlişkin İmgesel Algılara Yönelik Durum

Araştırmada yarı yapılandırılmış görüşme formunda yer alan “*Dijital benlik kavramının sizde uyandırdığı imgesel algılar nelerdir?*” şeklindeki soruya çalışma grubu üyelerinin vermiş oldukları yanıtlar içerik analizine tabi tutularak gruplandırılıp alt temalar şeklinde tablo 1’de gösterilmiştir. Tabloya bakıldığında sosyal bilgiler öğretmenlerinin konuya ilişkin farklı algılara sahip oldukları gözlemlenmektedir.

Tablo 1. Çalışma grubu üyelerinin sanallaşmaya ilişkin imgesel algıları

<i>1.Tema: Dijital Benlik Oluşuma İlişkin İmgesel Algılar</i>		
<i>Alt Temalar</i>		<i>f</i>
<i>G.1.</i>	<i>Teknolojik Bakış</i>	<i>12</i>
<i>G.2.</i>	<i>Sanal kimlik</i>	<i>4</i>
<i>G.3.</i>	<i>Değişken sosyal benlik</i>	<i>4</i>
<i>Toplam</i>		<i>20</i>

Dijital Benlik Oluşumunda Sosyal Bilgiler Eğitimindeki Beceri Durumu

Araştırma çalışma grubu üyelerine sorulan “Sosyal bilgiler eğitimi dersinde yer alan hangi beceriler dijital benlik oluşumu üzerinde sizce daha çok etkilidir?” şeklindeki soruya çalışma grubunu oluşturan sosyal bilgiler öğretmenlerinin birkaç beceri üzerinde yoğunlaştıkları tablo 2’de görülmektedir.

Tablo 2. Çalışma grubunun sosyal bilgiler eğitimindeki beceri durumuna ilişkin algıları

2.Tema: Sosyal bilgiler eğitiminde becerilerin dijital benlik oluşumuna etkisi		
Alt Temalar		f
G.1.Dijital okuryazarlık		4
G.2.Çoklu bakış açısı edinme		4
G.3.Sosyal katılım		8
G.4.Gözlem		4
Toplam		20

Sosyal Bilgiler Eğitiminin Dijital Benlik Oluşumu Üzerindeki Etki Durumu

Eğitim-öğretim sürecindeki sanallaşma faaliyetlerinin sosyal bilgiler dersine yansımalarını tespit etmek amacıyla araştırmada çalışma grubu üyelerine “Sosyal Bilgiler Eğitimdeki sanallaşma faaliyetlerinin dijital kimlik oluşumu üzerinde etkili olduğunu düşünüyor musunuz, neden?” şeklinde soru yöneltilmiştir. Çalışma grubu üyeleri soruya vermiş oldukları tablo 3’deki yanıtları vermişlerdir. Çalışma grubu üyelerinin vermiş oldukları yanıtlar incelendiğinde sosyal bilgiler öğretmenlerinin konuya ilişkin çeşitli algılara sahip oldukları söylenebilir.

Tablo 3. Çalışma grubunun sosyal bilgiler eğitiminde sanallaşmanın dijital benlik oluşumu durumuna ilişkin algıları

3.Tema: Sosyal bilgiler eğitiminde sanallaşmanın dijital benlik oluşumu üzerindeki etkileri		
Alt Temalar		f
<i>Evet</i>	G.1.Teknolojik içeriğe dayalı etkinliklere yer verilmesi	10
	G.2.Dijital okuryazarlık becerisini kazandırması	9
<i>Hayır</i>	G.3.Teorik aktarıma dayalı olması	1
Toplam		20

Sonuç ve Öneriler

Araştırmada elde edilen bulgulardan hareketle şu sonuçlar elde edilmiştir:

- ✓ Sosyal bilgiler öğretmenlerinin dijital benlik algılarının farklı olduğu,
- ✓ Sosyal bilgiler derslerinde sanallaşma etkinliklerinin dijital benlik oluşumu üzerinde etkili olduğu,
- ✓ Dijital benlik oluşumunda sosyal bilgiler eğitimi becerilerinden dijital okuryazarlık, sosyal katılım ve gözlemin etkili olduğu sonuçlarına ulaşılabilir.

Bu sonuçlardan hareketle;

- ✓ Eğitim kurumlarımızda sanallaşmaya yönelik eğitimler öğretmenlerimize verilmelidir.
- ✓ Dijitalleşme kavramının olumlu kullanımına ilişkin öğrencilere model uygulamalar gösterilmelidir.

Kaynakça

- Kurtkan Bilgiseven, A.(1982). Genel Sosyoloji: Kavramlar-Nazariyeler Bünye (Türkiyede Sosyal Tabakalaşma Değişme ve Sosyal Gelişme. İstanbul.
- Hayes, N. (2011). Psikolojiyi Anlamak. İstanbul: Optimist Yayın ve Dağıtım.
- Çakmak, V.(2017). Online Benlik Sunumu ve Narsisizm Arasındaki İlişki: Üniversite Öğrencileri Üzerinde Bir Araştırma. *Online Academic Journal of Information Technology*, 30(9),140-141.
- Akmeşe, Z. ve Deniz, K.(2017). Selfie: Benliği Çerçevelemek. *Akademik Sosyal Araştırmalar Dergisi*, 59(5), 283-289.
- İşman, A., Buluş, B. ve Yüzüncüyıl, K.S.(2016). Sosyalleşmenin Dijitale Dönüşümü ve Dijital Benliğin Sunumu. *TRT Akademi*, 1(2), 610-617.



INTERNATIONAL SOCIETY FOR RESEARCH IN
EDUCATION AND SCIENCE

www.isres.org

IOWA STATE
UNIVERSITY



GAZIANTEP
UNIVERSITY

EVMS
Eastern Virginia Medical School



<http://www.icres.net>

International Conference on Research in Education & Science
April 28 - May 01, 2019 • CESME-IZMIR/TURKEY